

DEPARTMENT OF THE ARMY TECHNICAL MANUAL

**OPERATOR, ORGANIZATIONAL,
DS, AND GS MAINTENANCE MANUAL**

**OPERATION AND MAINTENANCE
INSTRUCTIONS FOR OSCILLOSCOPE
FD-765MH (PORTASCOPE)**

**This copy is a reprint which includes
current pages from Changes 1 through 3,**

**HEADQUARTERS, DEPARTMENT OF THE ARMY
APRIL 1968**

WARNING

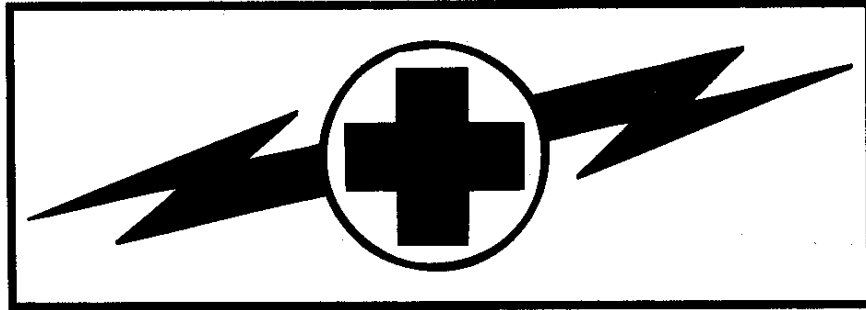

DANGEROUS VOLTAGE

is used in the operation of this equipment

DEATH ON CONTACT

may result if personnel fail to observe safety precautions

Never work on electronic equipment unless there is another person nearby who is familiar with the operation and hazards of the equipment and who is competent in administering first aid. When the technician is aided by operators, he must warn them about dangerous areas.

Whenever possible, the power supply to the equipment must be shut off before beginning work on the equipment. Take particular care to ground every capacitor likely to hold a dangerous potential. When working inside the equipment, after the power has been turned off, always ground every part before touching it.

Be careful not to contact high-voltage connections when installing or operating this equipment.

Whenever the nature of the operation permits, keep one hand away from the equipment to reduce the hazard of current flowing through vital organs of the body.

WARNING

Do not be misled by the term "low voltage." Potentials as low as 50 volts may cause death under adverse conditions.

For Artificial Respiration, refer to FM 21-11.

EXTREMELY DANGEROUS POTENTIALS

greater than 500 volts exist in the following units:

Cathode ray tube. 1.....13 kvdc

Power supply.....3 kvdc

**Operator, Organizational, DS, And GS
Maintenance Manual**

**OPERATION AND MAINTENANCE INSTRUCTIONS FOR
OSCILLOSCOPES 765MH AND 765MA
(PORTASCOPIES)**

	Paragraphs	Page
CHAPTER 1. INTRODUCTION		
Section I. General	1-1 - 1-6	1-1
II. Description and data	1-7 - 1-9	1-2
CHAPTER 2. OPERATING INSTRUCTIONS		
Section I. Service upon receipt of materiel	2-1 - 2-2	2-1
II. Controls and indicators	2-3 - 2-6	2-1
III. Operation under usual conditions	2-7 - 2-13	2-3
IV. Check procedure	2-14 - 2-15	2-7
CHAPTER 3. THEORY OF OPERATION		
Section I. General theory	3-1 - 3-3	3-1
II. Functional theory-power supply	3-4 - 3-5.1	3-2
III. Functional theory-dual trace plug-in type 76-02A (Y-deflection)	3-6 - 3-11	
III.1. Functional theory-dual trace plug-in 79-02A and CRT termina- tion network	3-11.1 - 3-11.2	3-6
IV. Functional theory-delaying sweep plug-in type 74-13A (X-deflection)	3-12 - 3-16	3-6.2
V. Functional theory-delaying sweep plug-in 74-13A (X- deflection), newer model	3-17 - 3-23	3-15
CHAPTER 4. BLOCK DIAGRAMS AND FUNCTIONAL SCHEMATICS	Figures	Page
Power supply block diagram	4-1	4-1
Oscilloscope, block diagram	4-2	4-2
Power supply, functional schematic	4-3	4-3
Dual trace plug-in (type 76-02A), functional schematic	4-4	4-4
Dual trace plug-in (type 7902A) block diagram	4-4.1	4-6
Y channel amplification using dual trace plug-in 79-02A. functional schematic	4-4.2	4-6.1
Delaying sweep plug-in (type 74-13A), functional schematic	4-5	4-6.6
CHAPTER 5. MAINTENANCE INSTRUCTIONS	Paragraphs	Page
Section I. Repair parts, tools, and equipment	5-1 - 5-3	5-1
II. Preventive maintenance	5-4 - 5-8	5-1
III. Troubleshooting	5-9	5-1
IV. Corrective Maintenance	5-10 - 5-13	5-11
CHAPTER 6. SCHEMATICS	Figures	Page
Main frame, oscilloscope 765MH with mod 116, schematic	6-1	6-2
Main frame; low voltage power supplies, 765MH (newer), 765MH/F and 765MA, schematic	6-1.1	6-7
Main frame; CRT and high voltage circuits, 765MH (newer) and 765MH/F, schematic	6-1.2	6-8
Main frame; CRT and high voltage circuits, 765MA, schematic	6-1.3	6-8.1
Dual trace plug-in (type 76-02A with mod 101 and delay line), schematic	6-2	6-9

	Figures	Page
Dual trace plug-in (type 79-02A with mod 103 and delay line), schematic	6-2.1	6-14
Delaying sweep plug-in, older version (type 74-13A with mod 101), schematic	6-3	6-18
Delaying sweep plug-in, newer version (type 74-13A with mod 101), schematic	6-4	6-24

CHAPTER 7. SHIPMENT AND STORAGE AND DESTRUCTION OF
MATERIEL TO PREVENT ENEMY USE

Section I. Shipment and storage	7-1 - 7-4	7-1
II. Destruction of materiel to prevent enemy use	7-5 - 7-8	7-2
Appendix REFERENCES		A-1
INDEX		I-1

CHAPTER 1 INTRODUCTION

Section I. GENERAL

1-1. Scope

a. This manual contains instructions for operation, and for organizational, DS, and GS maintenance of oscilloscopes 765MH and 765MH/F (Portascopes) (Fig. 1-1).

b. Precautionary measures to be taken during operation and maintenance of the oscilloscopes are contained in appropriate paragraphs of this manual.

1-2. Reporting Equipment Publication Improvements

Report of errors, omissions, and recommendations for improving this publication by the individual user is encouraged. Reports should be submitted on DA Form 2028 (Recommended Changes to Publications) and forwarded direct to Commander, U.S. Army Missile Command, ATTN: AMSMI-NPM, Redstone Arsenal, AL 35809.

1-3. Maintenance Allocation

The prescribed maintenance responsibilities will apply as reflected in TM 9-6625-1753-25P.

1-4. Forms, Records and Reports

Refer to TM 38-750 for the forms, records, and reports required from units maintaining this equipment.

1-5. Differences Among Models

a. *General.* A difference among models exists when two or more configurations of the same item are used in the equipment. In this equipment these differences are permanent. A permanent difference among models exists when an item is changed during manufacture, but the change does not warrant modification (or retrofit) of the item already in the field. This difference usually arises when the equipment is improved, although the older model can perform its function satisfactorily.

b. *Oscilloscope 765MH Main Frame Changes.* There are two models of the main frame. The earlier model has an a 11-vacuum tube high-voltage rectifier circuit, while the later model has a solid-state high-voltage rectifier circuit. Replacing the vacuum tube rectifier with solid state rectifiers increases the reliability of the high-voltage power supply.

c. *Oscilloscope 765MH/F.* With the exception of circuits which provide a higher frequency response, oscilloscope 765MH/F is similar to the newer models of oscilloscope 765MH. To obtain the higher frequency response, CRT termination network 7062 is incorporated into the main frame. This termination provides facilities for adapting dual trace plug-in 79-02A to the unit. Dual trace plug-in 79-02A has a frequency response of 100 mc to the 3 db point, and frequencies as high as 250 mc can be observed using the instrument with this plug-in.

d. *Oscilloscope 765MH/F.* The round CRT of previous models has been replaced with a rectangular CRT. The high voltage power supply has been replaced with a circuit board assembly. A Z-axis circuit board assembly has been added to allow low level DC inputs to Z-axis.

Note. Do not use shorting type cap plug on EXT Z-axis input connector.

1-6. Nomenclature and Reference Designations

a. Table 1-1 lists the reference designation and official nomenclature of the assemblies that comprise oscilloscopes 765MH or 765MH/F (Portascope).

Table 1-1. Nomenclature and Reference Designations

Reference designation	Official nomenclature	TM nomenclature
1 or 2	Oscilloscope, main frame (with ¹ mod 116)	Main frame
8	Delaying sweep plug-in, type 74-13A (with ¹ mod 101)	Delaying sweep plug-in
9	Dual trace plug-in, type 76-02A (with ¹ mod 101 and delay line or dual trace plug-in, type 79-02A (with ¹ mod 103 and delay line)	Dual trace plug-in

¹/Mod 161, mod 101, and mod 103 are explained in TM 9-6625-1753-25P.

b. A reference designation provides a convenient code that completely identifies each part in the oscilloscope. The first letter in the grouping is the class of part designation, the second digit or number indicates the assembly in which the part is to be found, and the remaining numbers represent the part designator. For example, Q8101 represents transistor number 101 in the delaying sweep plug-in assembly.

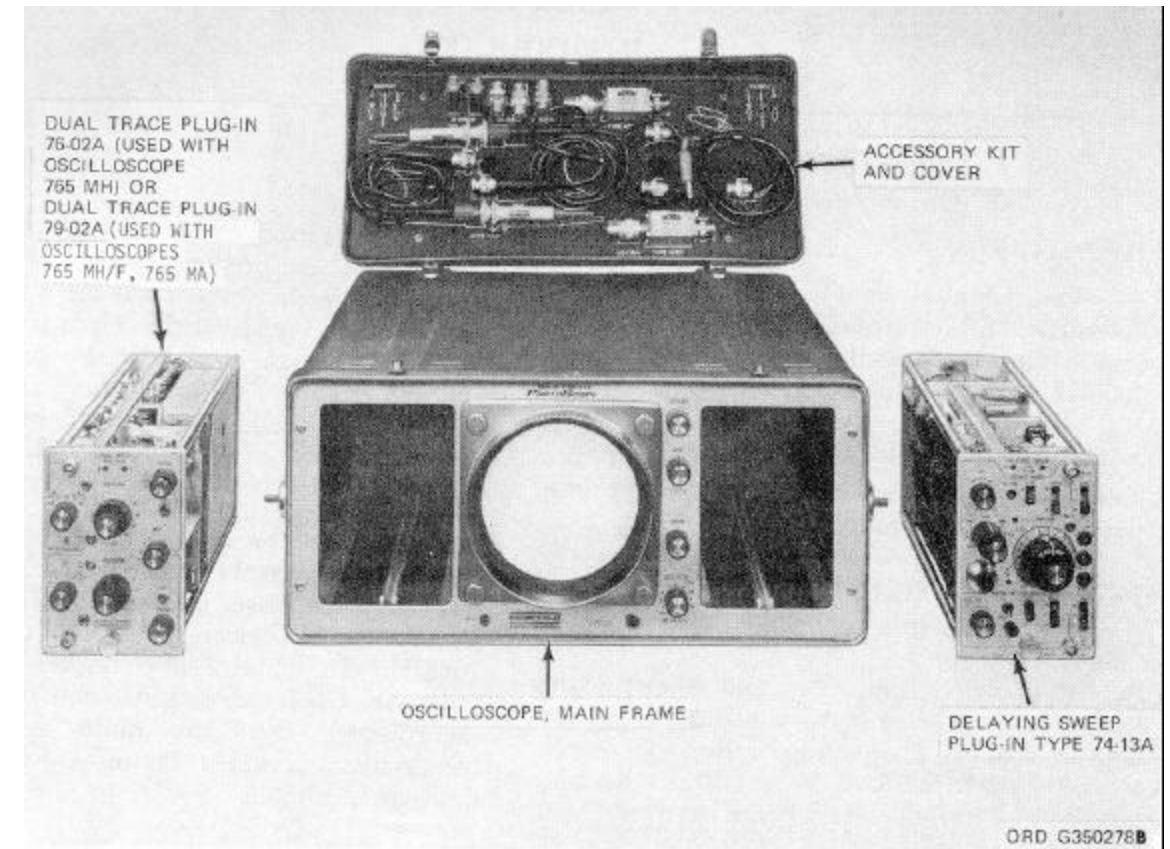

Figure 1-1. Oscilloscope FD-765MH or FD-765MH/F (portascopes).

Section II. DESCRIPTION AND DATA

1-7. Physical Description

a. *Complete Unit.* There are three assemblies in the oscilloscope (Fig. 1-2). These are: the main frame, the dual trace plug-in, and the delaying sweep plug-in. In addition, there is an accessory kit located inside the cover.

b. *Main Frame.* The main frame is a metal structure that mounts the cathode-ray tube (CRT) and the power supplies. It has a cavity on each side for holding the dual trace and delaying sweep plug-in's. The low-voltage and high-voltage power supplies are located on the rear plate, and the CRT, which spans the whole structure, is located in the center of the main frame. Both of these items are accessible by removing the fiberglass case. The CRT screen is covered by a neutral, circularly-polarized filter with a 6 by 10-centimeter graticule for measuring the displayed waveform. The filter is held in place by an aluminum bezel. It is mounted on the front panel of the main frame which also mounts five CRT controls.

c. *Dual Trace Plug-In and Delaying Sweep Plug-In.* These two plug-in units are physically and functionally interchangeable. However, there is no provision for coupling an unblanking pulse from the left-hand plug-in to the CRT, so when a vertical sweep is used, the trace is not blanked between sweeps. Each plug-in is constructed with guide rails to provide for accurate insertion into the main frame cavity. Guide pins assure proper mating of the male connector with the female connector located on the rear plate of the main frame.

Note. Dual trace plug-in 79-02A is to be used for Y deflection (in the left cavity) only.

d. *Accessory Kit.* The accessory kit consists of the following:

(1) Two attenuator probes X10 (probe assembly 7999B, test prods 4299B, or probe assembly 7994B).

Note. Probes 7999B or 7994B are for oscilloscope 765-MH/F, while probe 4299B is for the 765MH.

(2) Two sets of tip adapters (three per set (probe test kit 50288561).

(3) One connecting cable, BNC-to-alligator clip (test lead 50288581, type 7083).

(4) Two connecting cables, BNC-to-BNC to rf cable assembly 50288581, type 7082).

(5) Two terminators, 50-ohm, 2 watt (dummy load 4285A).

(6) Two UG1090/U binding-post-to- BNC male connectors 0903640, type 7080.

(7) Power cable 50301390.

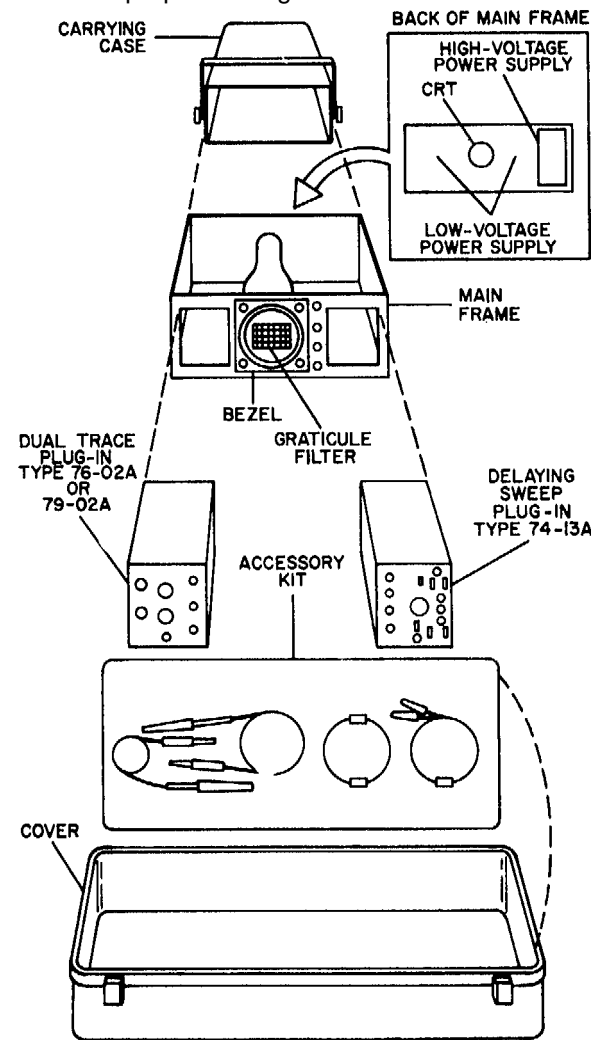

ORD G350279A

Figure 1-2. Components of oscilloscope.

1-8. Operation and Maintenance Data

A brief description of the operation and maintenance data is given in table 1-2. This table enables operating and maintenance personnel to determine at a glance the operating capabilities of the equipment.

Table 1-2. Oscilloscope Operation and Maintenance Data

Item	Data	Item	Data
Power Requirements		Minimum external trigger (X1 probe)	0.5 volt peak-to peak (dc to 1 MHz) or 1.0 volt peak-to-peak (up to 10 MHz)
Power	230 watts	External trigger input impedance	1 megohm, shunted by 40 pf nominal
Voltage	105 to 125 vane or 210 to 250 vac (at 60 Hz)	Delay	250 nsec to 20 sec
Frequency	48 to 1000 Hz	Dual Trace Plug-In Bandwidth	
Temperature Limits		Dc coupled	Dc to 25 MHZ own db at 25 MHZ
Storage	-40° to +85°C (-40° to 185°F)	Ac coupled	10 Hz
Operating	-30° to 60°C (-22° to +140°F)	External trigger input impedance	1 megohm, shunted by 40 pf
Humidity	40°C (104°F), 95% relative humidity	Rise time	15 nsec, driven from 25-ohm source
Altitude Range		Sensitivity	5 mv div to 25 volts div
Operational	15,000 ft	Dual trace Plug-In 79-02A	
Non-operating	50,000 ft	Bandwidth (3 db points)	
CRT		Dc coupled	
Fluorescence color	Green	X1 position	0 to 100 MHz
Light transmittal	52%	X10 position	0 to 90 MHz
Persistence	70 μsec	Ac coupled	
Accelerating potential	13 kv	X1 position	16 Hz to 100 MHz
X axis direct input	10 to 15 volts/cm	X10 position	16 Hz to 90 MHz
Y axis direct input	2.5 to 3.5 volts/cm		
Delaying Sweep Plug-In		Note. Response to frequencies as high as 250 MHz is possible.	
Sweep rate	10 nsec div to 5 sec div	Sensitivity	10 mv/div to 50 v/div
Bandwidth (dc coupled)	Dc to 2 MHz, down 3 db at 2 MHz	Accuracy (voltage measurements)	±3%
Minimum trigger rate:		Input impedance	1 megohm shunted by 14 pf nominal
Ac coupling	80 Hz		
Afc coupling	10 kHz, with a minimum of 100 μsec rise or fall time		

1-9. Capabilities

The oscilloscope displays waveshapes of sampled electronic signals. It incorporates two major features: dual trace and delayed sweep.

a. *Dual Trace.* The dual trace feature allows you to view two separate signals at the same time. This could be useful, for example, in comparing the time delay of two logic inputs, or the before-and-after effects of a squaring circuit.

b. *Delayed Sweep.* The delayed sweep feature permits you to select and expand one segment of the displayed signal. For instance, you can measure the rise time of one pulse in a train of several.

CHAPTER 2
OPERATING INSTRUCTIONS

Section I. SERVICE UPON RECEIPT OF MATERIEL

2-1. General

a. When a new or reconditioned oscilloscope is first received by the using organization, it is the responsibility of the person-in-charge to determine whether the materiel is complete, and if it is in satisfactory condition in service. The service procedures of a general nature are listed in paragraph 2-2.

b. Make a record of all deficiencies found so that they may be either remedied by the using organization or referred to the direct support and general support maintenance personnel.

2-2. General Services

a. Carefully note all markings and/or tags attached to the materiel, since they may contain information relating to operation and maintenance.

b. Refer to the appendix for applicable forms, records, and reports for inspection. Inspect the records of maintenance, previously performed on the materiel to determine its maintenance background. A record of progressive repairs may indicate a defective unit, while a record of regular preventive maintenance may indicate a unit in excellent condition.

Section II. CONTROLS AND INDICATORS

2-3. General

This section contains tables 2-1 through 2-3 which list the various controls and indicators of the oscilloscope, and describe the type and function of each.

2-4. Main Frame, Controls and Indicators

Table 2-1. Main Frame, Controls and Indicators (Fig. 2-6)

Key	Control, Indicator or Connector	Function
11	INTENSITY control	Regulates brightness of trace on CRT screen.
9	ASTIG control	Adjusts shape of spot on CRT screen.
10	BEAM ROTATE control	Rotates the CRT electron beam to compensate for the EARTH'S magnetic effect on trace alinement.
39	FOCUS control	Adjust sharpness of trace on CRT screen.
38	SCALE ILLUM control and power switch	Dimmer for scale lamps and turns on power to oscilloscope.

2-5. Dual Trace Plug-In, Controls and Indicators

Note. Since the controls and indicators for channel A and B are identical, only the controls for channel A are described.

Table 2-2. Dual Trace Plug-In, Controls and Indicators (Fig. 2-6)

Key	Control, Indicator or Connector	Function
2	Beam position indicators	Arrow next to glowing lamp indicates the direction that trace is deflected (off the CRT screen).
4, 43	ATTEN BAL control	Screwdriver adjustment to prevent displacement of the trace when VARIABLE and VOLTS/DIV controls are activated.
5, 44	POSITION control	Positions the trace up or down on the CRT screen.
6, 42	DC BAL control	Screwdriver adjustment to prevent displacement of the trace when the VARIABLE control is activated.
7	MODE switch	Selects the following dual-trace modes: A: Only channel A signal is displayed. B: Only channel B signal is displayed. ALT: Both channel A and Channel B signals are displayed on alternate sweeps. CHOP: Both channel A and channel B signals are displayed. Switching from channel A to channel B is at an arbitrary rate (approximately 60 kc). This mode of operation is used when a single transient is to be observed at two points in a circuit, and also for slow sweeps when the ALT mode has too much flicker. A + B: Both channel A and B signals displayed at the same time. The overall display is the algebraic sum of both signals.
1, 45	VOLTS/DIV switch	Selects accurately calibrated vertical deflection sensitivities of 0.005, 0.01, 0.02, 0.05, 0.1, 0.2, 0.5, 1, 2, 5, or 10 volts per division when the VARIABLE control is in the CAL position.
3, 46	VARIABLE control	Provides uncalibrated variable vertical deflection sensitivities between settings of the VOLTS/DIV switch (up to 25 volts/div for a setting of 10), when turned counterclockwise from the CAL position.
49, 52	NORM-INVERT switch	Selects the polarity of the displayed waveform. Provides ac or dc coupling of the input signal in the NORM or INVERT position. NORM: Displayed waveform has the same polarity as the input signal. INVERT: Displayed waveform has the opposite polarity of the input signal (positive-going input signal is displayed as a negative-going signal). GND: Grounds the amplifier input circuit.
50, 51	GAIN ADJ control	Screwdriver adjustment for setting the calibrated vertical deflection sensitivity.

2-5.1. Dual Trace Plug-In 79-02A, Controls, Indicators, and Connectors

Table 2-2.1. Dual Trace Plug-In 79-02A, Controls, Indicators, and Connectors (Fig. 2-6)

Key	Control, Indicator or Connector	Function
72	BEAM FINDER switch	A spring-loaded switch. If the beam is off the screen, the switch may be depressed to locate the beam.
62	CH2 OUT connector	The channel 2 preamplifier output is available at this BNC connector, connected through a 5,000 ohm resistor.

Table 2-2.1. Dual Trace Plug-In 79-02A, Controls, Indicators, and Connectors (Fig. 2-6) - Continued

Key	Control, Indicator or Connector	Function
68, 73	DC-AC-GND switch	This three-position slide switch provides the following connections: DC: The signal connected to the 1 MEG 14 PF connector is connected through a resistor to the channel amplifier AC: A capacitor is connected between the input signal and the channel amplifier. GND: The input to the amplifier is grounded. (The GND position may be used to establish a reference level.)
55, 64	DC BAL control	A screwdriver adjustment to prevent displacement of the trace when the VARIABLE control is operated.
70, 76	GAIN ADJ control	A screwdriver adjustment for setting the calibrated vertical deflection sensitivity.
60	MODE switch	The switch selects any of the following modes: CH1: Only the signal applied to the upper amplifier is displayed. CH2: Only the signal applied to the lower amplifier is displayed. ALT: Channel 1 and channel 2 signals are displayed on alternate sweeps. CHOP: Channel 1 and channel 2 signals are displayed (electronic switch). The display switches between channel 1 and channel 2 at a rate of 100 kHz or 1 MHz, as determined by chop rate switch. ADDED: Both channel 1 and channel 2 signals are displayed at the same time. The algebraic sum of the two signals, summed in accordance with the polarity selected by the NORMAL-INVERT switch is the resultant display.
71, 75	NORM-INVERT switch	Selects the polarity of the displayed signal: in the NORM position, the waveform is displayed with the same polarity as the input signal; in the INVERT position, the waveform is inverted.
56, 65	POSITION control	Positions the trace up or down on the CRT screen.
61	TRIGGER switch	Provides a choice of internal trigger sources: in the NORMAL switch setting, the composite signal driving the vertical deflection plates is selected; in the CH2 ONLY switch position, the channel 2 signal is selected.
58, 66	VOLTS, DIV switch	Selects accurately calibrated vertical deflection sensitivities of 0.1, 0.2, 0.5, 1, 2, 5, 10, or 20 volts per inch when the VARIABLE control is in the CAL position.
59, 67	VARIABLE control	Provides variable vertical sensitivity settings and extends the range of the instrument to 50 volts/div. When pulled to the PULL X10 position, the gain of the amplifier is increased by a factor of 10.
57, 63	UNCAL indicator	Illuminates when the VARIABLE CONTROL IS control is set to a position other than CAL, (un-calibrated voltage readings).
69, 74	1 MEG 14 PF connector	A BNC connector, used to connect signals to channel 1 or channel 2.

2-6. Delaying Sweep Plug-in, Controls and Indicators

Table 2-3. Delaying Sweep Plug-In, Control., Indicators, and Connectors (Fig. 2-6)

Key	Control, Indicator or Connector	Function
36	NORMAL AND DELAYING TRIGGERING controls: LEVEL control	Selects specific voltage (± 10 volts) which the triggering signal must exceed before the sweep fires.
36	PULL EXT 10 switch	Extends the range of the voltage (± 100 volts) which the triggering signal must exceed before the sweep fires.
33	AUTO-NORM switch (on older version model 74-13A)	Selects mode of operation for normal sweep. NORM: Requires an input signal from dual trace plug-in to fire sweep. AUTO: Automatic trigger circuit is activated, generating a trigger pulse to fire the sweep. Input signal from dual trace plug-in is not required.
34	HF STAB control & NORM-RECUR switch (on older version 74-13A)	Selects recurrent operating mode for normal sweep. Varies the natural repetition rate of the recurrent normal sweep, providing stable synchronization of very high frequencies (to 50 MHz).
28.1	NORM-AUTO-HF RECUR switch (on newer version 74-13A)	Perform similar function as 33 and 34 above.
32	SLOPE switch	"+" Position: Triggering pulse fires the normal sweep on the positive-going portion of the input signal. "-" Position: Triggering pulse fires the normal sweep on the negative-going portion of the input signal.
30	COUPLING switch	Three-position switch. Selects the following modes of coupling the input signal to the triggering circuit in the normal sweep circuit. AC: Input signal is coupled through a high-pass filter having a frequency cutoff of 80 Hz. ACF: Input signal is coupled through a high-pass filter having a frequency cutoff of 10 kHz. DC: Input signal is coupled direct. This mode provides optimum trigger sensitivity when very low frequency waveforms are monitored.
29	SOURCE switch	Three-position switch. Selects the source of the trigger. INT: Internal trigger derived from the input signal. EXT: External trigger coupled through EXT TRIG connector. LINE: Internal trigger derived from the 6.3 vac source. Trigger rate depends on powerline frequency.
25	SAW connector (banana jack)	Provides a positive saw-tooth signal of approximately 25 volts which is coincident with the normal sweep.
27	"+" GATE connector (banana jack)	Provides a positive pulse of approximately 2.5 volts which is time-coincident with the normal sweep.
31	EXT TRIG connector (BNC connector)	Connects external trigger to normal sweep.
14	DELAYING SWEEP controls: LEVEL control and X AMP ATTEN control	Selects specific voltage (± 10 volts) which the triggering signal must exceed before the delay sweep fires. In addition, this control serves as the horizontal amplifier gain control when the DISPLAY LOGIC switch is set to X AMP.

Table 2-3. Delaying Sweep Plug-In, Controls, Indicators, and Connectors
(Fig. 2-6) - Continued.

Key	Control, Indicator or Connector	Function
14	PULL EXT 10 switch	Extends the range of the voltage (± 100 volts) which the triggering signal must exceed before the delayed sweep fires.
15	DLY ZERO control	Screwdriver adjustment for calibrating the DELAY VERNIER control to provide a precise zero adjustment.
18	SLOPE switch	"+" Position: Triggering pulse fires the delayed sweep on the positive-going portion of the input signal. "-" Position: Triggering pulse fires the delayed sweep on the negative-going portion of the input signal.
20	COUPLING switch	Three-position switch. Selects the following modes of coupling the input signal to the triggering circuit in the delayed sweep circuit. AC: Input signal is coupled through a high-pass filter having a frequency cutoff of 80 cycles. ACF: Input signal is coupled through a high-pass filter having a frequency cutoff of 10 cycles. DC: Input signal is coupled direct. This mode provides optimum trigger sensitivity when very low frequency waveforms are monitored.
21	SOURCE switch	Three-position switch. Selects the source of the trigger that is applied to the delayed sweep. INT: Internal trigger derived from the input signal. EXT: External trigger coupled through EXT TRIG connector. LINE: Internal trigger derived from the 6.3 vac source. Trigger rate depends on powerline frequency.
19	EXT TRIG-X AMP connector (BNC connector)	Connects external trigger to delayed sweep. In addition it connects an external signal directly to the horizontal deflection amplifier.
22	SWP CAL control	Screwdriver adjustment to compensate for difference in deflection plate sensitivities when the delaying sweep plug-in is switched from one cavity in the main frame to the other.
23	"+" GATE connector (banana jack)	Provides a positive pulse of approximately 2.5 volts which is time-coincident with the delaying sweep.
28	TIME/DIV switch	Selects the normal sweep speed. Provides calibrated sweeps (time per division) of 0.1 microseconds to 2 seconds in twenty-three steps.
26	DELAYED SWEEP-PULL TO UNLOCK switch (black knob)	When pulled and rotated it selects the delayed sweep speed. Provides calibrated sweeps of 0.1 microseconds to 2 seconds in twenty-three steps.
24	Sweep vernier control	Varies the normal or delayed sweep (when rotated counterclockwise from the CAL position), depending on the position of the DISPLAY LOGIC switch.
12	DISPLAY LOGIC switch	Five-position switch. Selects sweep operational mode. NORM: Only the normal sweep is displayed. It can be triggered internally by the displayed signal or by a signal applied to the lower EXT TRIG connector.

Table 2-3. Delaying Sweep Plug-in, Controls, Indicators, and Connectors (Fig. 2-6) -Continued

Key	Control, Indicator or Connector	Function
		TRIG-STROBE: Both the normal and delayed sweeps are displayed. The delayed sweep appears as a bright segment (strobe) superimposed on the normal sweep. TRIG-DLY'D: Only the delayed sweep is displayed. The bright segment is expanded to cover the entire CRT screen. ARM-STROBE: Functions the same as TRIG-STROBE mode, except that the delayed sweep (strobe) starts after the selected delay interval, when the delay sweep circuit receives a trigger. ARM-DLY'D: Functions the same as TRIG-DLY'D, except that the sweep starts after the selected delay interval, when the delayed sweep circuit receives a trigger. X AMP: Permits an external source to be substituted in place of the internal sweep circuits.
13	POSITION control	Positions the trace horizontally.
13	PULL X10 switch	Expands the sweep, magnifying the display 10 times.
17	UNCAL indicator	Indicates that the sweep vernier control is operational and the sweep time is no longer calibrated.
37	DELAY VERNIER control	Controls the distance on the CRT screen from the start of the normal sweep to where the delayed sweep is either triggered or armed.
35	SWP READY indicator	Indicates that the delayed sweep is armed and ready to be triggered.
16	Beam position indicators	Arrow next to glowing lamp indicates the direction that the trace is deflected off the CRT screen.

Section III. OPERATION UNDER USUAL CONDITIONS

Note. The following text, channel A is used interchangeably with channel 1, and channel B with channel 2. In each remaining case where there is a difference between oscilloscopes FD-765MH and FD-765MH/F, the name of the control and/or the control setting applicable to oscilloscope FS-765MH/F is given in parenthesis.

2-7. Starting Procedure

a. With the SCALE ILLUM switch set to OFF, connect the power cord to the connector (3) Delaying sweep plug-in at the rear of the oscilloscope and then to the power source, 105 to 125 volts or 210 to 250 volts alternating current (ac).

Caution: Make sure the .230V-115V switch on the main frame is set to the proper position.

b. Set the controls as follows:

- (1) *Main frame*
 - INTENSITY control.....fully counterclockwise
 - ASTIG control.....midposition
 - FOCUS controlmidposition
- (2) *Dual trace plug-in*
 - MODE switch.....A (CH1)
 - VOLTS/DIV switch.....10
 - POSITION control.....midposition
- (3) *Delaying sweep plug-in*
 - DISPLAY LOGIC switch.....NORM
 - NORMAL AND DELAYING TRIGGERING LEVEL control.....0
 - NORMAL AND DELAYING TRIGGERING COUPLING switch.....DC

NORMAL AND DELAYING TRIGGERING SOURCE switchLINE
 AUTO-NORMAL-HF RECUR Switch.....NORMAL

- c. Rotate the SCALE ILLUM control fully clockwise. The pilot lamp should illuminate.
- d. After about 1 minute, rotate the INTENSITY control clockwise until a horizontal trace appears on the screen. If a trace doesn't appear, check the beam position indicators on the dual trace plug-in (press the BEAM FINDER on the dual trace plug-in 79-02A) and the delaying sweep plug-in. If one or more of these lamps are glowing, the trace is off the screen in the direction indicated by the arrow adjacent to the glowing lamp.
- e. Use the POSITION controls on both plug-in units to position the trace on the screen.
- f. Adjust the FOCUS, ASTIG, and INTENSITY controls for a sharp trace. Since these adjustments are somewhat interdependent, it may be necessary to readjust the FOCUS and ASTIG controls as the INTENSITY setting is changed

Caution: The trace can damage the cathode-ray screen if the INTENSITY control is advanced too far on slow-moving sweeps, or if the trace is allowed to contract to a spot. The INTENSITY control should be adjusted until the trace can be viewed comfortably. Rotate the INTENSITY control until the trace is dim or turned off when the oscilloscope is to be left unattended.

2-8. Use of Probe

- a. Set up the probe for use as follows:
 - (1) Connect the probe to the channel A or channel B input BNC connector, as desired.
 - (2) Set the following controls to the indicated position.

VOLTS/DIV switch to .02 (0.1-MH/F model)
 NORM-INVERT switch (and AC-DC-GND switch) to NORM-DC
 MODE switch to the channel selected
 TIME/DIV switch to 5 mSEC at 60 cycles, 1 mSEC at 400 cycles

(3) Touch the probe tip to the CAL 1V connector. Several cycles of the calibration signal waveform (square wave) will be displayed on the screen.

(4) Note the shape of the square wave. If it is not flat on top and bottom, adjust the capacitor in the body of the probe. To do, this, first rotate the grooved locking device counterclockwise until it turns freely. Next rotate the body of the probe until the top and bottom of the square wave is flat. Finally, rotate the grooved locking device clockwise until it will no longer turn. (You may have to repeat this procedure several times to obtain the required results.)

b. Be careful in selecting the measuring point. Although the oscilloscope has a high input impedance and the probe increases the input impedance from 1 to 10 megohms, the source response may suffer if the probe is connected to a high-impedance source. To avoid this, make your measurements at the cathode of a stage instead of the grid or plate whenever possible.

c. When amplitude measurements are made with the probe, multiply the observed amplitude by the factor marked on the probe (X10).

2-9. Operation of the Dual Trace Plug-In

You can use the two-channel dual trace plug-in for single or dual-channel display. All the controls covered below are located on the dual trace plug-in 76-02A or 79-02A front panel.

- a. *Single Trace Presentation.*
 - (1) Rotate the MODE switch to channel A or B (CH1 or CH2)
 - (2) Connect the probe to the signal source.
 - (3) Set the NORM-INVERT switch (and the AC-DC-GND switch) to NORM-DC.
 - (4) If the waveform to be observed contains an undesirable dc component, set the NORM-INVERT (AC-DC-GND) switch to NORM-AC.

(5) Rotate the VARIABLE control fully clockwise until it rests in the detent position.

(6) Set the VOLTS/DIV switch to a position that will display the entire waveform on the screen. Start with the VOLTS/DIV switch fully counterclockwise and rotate it in clockwise direction until the entire trace comes into view. Use the POSITION control to center the trace on the screen..

(7) If voltages are not to be measured, you may rotate the VARIABLE control counterclockwise to reduce the display height. To make the display occupy as much of the vertical area as possible, rotate the VOLTS/DIV switch to the position that just puts the top and bottom of the waveform off-screen. Bring the whole track back into view by rotating the VARIABLE control counterclockwise.

(8) To expand a selected portion of the waveform vertically, rotate the VOLTS/DIV switch clockwise to a more sensitive position. A portion of the waveform may be off the screen. If the portion to be observed is not on the screen, bring it back by moving the waveform up or down, as required, with the POSITION control.

(9) Invert the display with the NORM-INVERT switch. In the NORM segment of the switch, positive-going pulses appear as positive-going pulses on the screen. In the INVERT segment of the switch, positive-going pulses appear as negative-going pulses on the screen.

b. *Dual Trace Presentation.* To display two waveforms, connect the probes from both channel inputs to the points to be measured.

(1) Use the CHOP mode for displaying continuous waveforms at slow sweep speeds (less than 1 millisecond per division). This mode eliminates most of the flicker present with alternating sweeps at slow speeds. To prevent the sweep from triggering on the chopping signal an external trigger is preferred.

(2) Square wave or sharp pulses at slow speeds may be difficult to synchronize in the CHOP mode. For these waveforms, if the display is not stable in the CHOP mode, set the MODE switch to ALT or use an external trigger.

(3) Use the ALT position of the MODE switch for all sweep speeds faster than 1 millisecond per division, and for all triggered modes of operation.

(4) To display the algebraic sum of two signals, set the MODE switch to A + B (ADDED). Both channel A and B NORMA-INVERT switches are set at NORM. For A-B presentation (algebraic difference of two signals), set the channel A NORM-INVERT switch to NORM and the channel B NORM-INVERT switch to INVERT. For a B-A presentation, set the channel A NORM-INVERT switch to INVERT and the channel B NORM-INVERT switch to NORM.

2-10. Operation of the Delaying Sweep Plug-IN

a. *General Triggering Information.* Since the triggering circuits of the normal and delayed sweep channels are similar, the controls described in the following instructions will pertain to both channels.

(1) *Triggering sources for normal and delayed sweeps.* You can select three sources of trigger pulses for the normal or delayed sweep with the SOURCE switch: LINE (frequency depends on power-line frequency), EXT. (any signal connected to the EXT TRIG connector), INT. (a sample of the input signal).

(a) *LINE.* Use the LINE position to observe signals that recur at the rate of the power source and when no other triggering source is available.

(b) *EXT.* To use external triggering, connect the probe between the trigger source and the EXT TRIG connector. Use external triggering under the following conditions:

1. To synchronize the display with a signal in the equipment under test.
2. To synchronize a slow-changing waveform, which is difficult to trigger internally, when a suitable triggering waveform (sharp pulse or square wave) is available at the same frequency, or a multiple or submultiple of it.

3. To compare the phase difference or time lag between two signals. Use one of the signals as the trigger source. The distance from the start of the trace to the start of the waveform is a measure of the time delay. For direct comparison, both signals may be displayed in dual-trace operation. Either CHOP or ALT position of the MODE switch will work.

(c) *INT.* Use the INT position if the input signal itself has sufficient amplitude to trigger the sweep. This is a convenient method of triggering connections are required. When the dual trace plug-in 79-02A is used, the TRIGGER switch provides two selections of trigger sources in INT operation. The channel 2 signal (CH2 ONLY setting) or the composite signal (NORMAL) may be selected.

(2) *Trigger coupling for normal or delayed sweep.* You can select three modes of operation with the COUPLING switch for coupling the triggering signal.

(a) *AC.* Use this position for input signals with frequencies greater than 80 cycles. Because a high-pass filter is provided in this mode, erratic triggering is prevented when positioning the trace vertically.

(b) *ACF.* Use this position for input signals with frequencies greater than 10 kc. This triggering mode provides stable triggering from a complex high-frequency waveform that contains undesirable low-frequency noise or line-frequency components.

(c) *DC.* Use this position for waveforms that change slowly (low-frequency input signals).

(3) *Use of SLOPE switch and LEVEL control.* You use the SLOPE switch and LEVEL control to start the trace at any selected point on the triggering waveform. The SLOPE switch allows the triggering to be selected on either the rising or the falling portion of the waveform. The LEVEL control sets the dc level at which triggering takes place.

(a) Figure 2-1 illustrates how the SLOPE switch is used to start the sweep on the rising or falling portions of the waveform. Remember, this has nothing to do with the polarity of the waveform. You use the setting that best displays the desired portion of the waveform. With the SLOPE switch set at "+", triggering would start the sweep at point A, but with the SLOPE switch set at "-", triggering would start the sweep at point B.

(b) Figure 2-2 illustrates how you can select the desired triggering point, using the SLOPE switch and the LEVEL control. The horizontal lines represent the dc level set by the LEVEL control. Notice how the setting of the SLOPE switch determines the point on the waveform where triggering occurs.

(c) If the COUPLING switch is set at DC, you can offset any dc component of the triggering waveform by adjusting the LEVEL control. For example, if the waveform has a negative dc component, the LEVEL control must be set positive by the same amount to give equivalent triggering as that obtained with a zero setting on a waveform without a dc component.

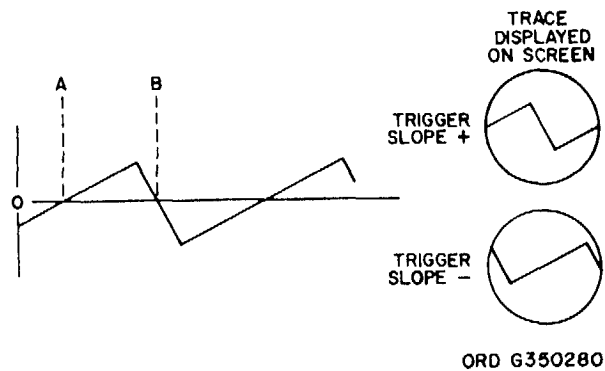

Figure 2-1. Use of the SLOPE switch.

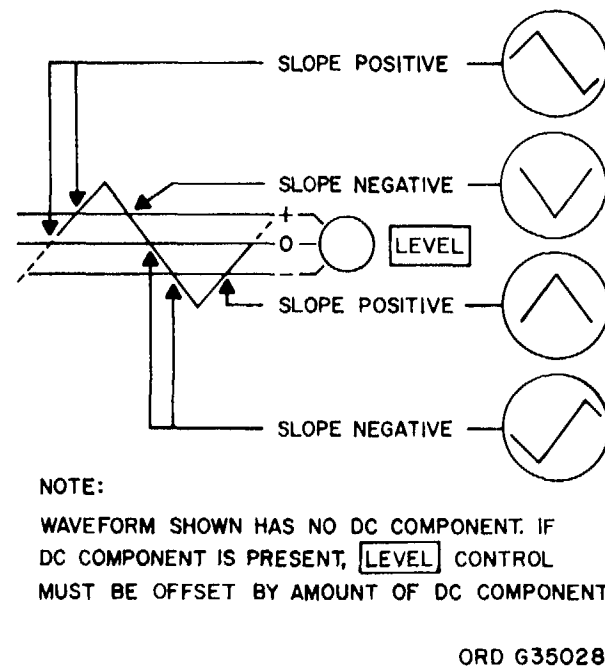

Figure 2-2. Use of triggering LEVEL and triggering SLOPE controls.

(d) The normal range of the LEVEL control is ± 10 volts. You can extend this range to ± 100 volts by pulling the LEVEL control into the PULL EXT 10 position.

(4) *Use of the HF STAB control.* When the normal sweep is operating in the recurrent mode, stable synchronization of high-frequency signals can be effected. This is done by rotating the HF STAB control out of its detent position. Rotating the HF STAB control varies the natural frequency of the recurrent normal sweep slightly so that exact submultiples of the trigger frequency can be selected.

b. *Triggering Instructions for Normal Sweep.*

Note. Review the general triggering information in a above before proceeding with the following instructions.

- (1) Perform the oscilloscope starting procedure (par. 2-7).
- (2) Connect the probe to the signal source. (Connect both probes for dual-trace operation.)
- (3) Connect the external trigger source to the EXT TRIG connector if external trigger is used.
- (4) Set the dual trace plug-in controls as required (par. 2-9).
- (5) Set other controls as follows:

DISPLAY LOGIC	NORM
NORMAL AND DELAYING TRIGGERING SLOPE	As required by triggering mode in use, par. a(3).
NORMAL AND DELAYING TRIGGERING COUPLING	AC, ACF, or DC, depending on conditions, par. a above.
NORMAL AND DELAYING TRIGGERING LEVEL	Fully clockwise.
HF STAB	NORM
TIME/DIV	Any setting that will display at least 1 cycle of the waveform.

- (6) Rotate the NORMAL AND DELAYING TRIGGERING LEVEL control until the trace appears.
- (7) Set the TIME/DIV switch to display as many cycles of the waveform as desired.
- (8) Adjust the NORMAL AND DELAYING TRIGGERING LEVEL control and set the SLOPE switch + or - position for trigger source used) until the desired portion of the waveform is displayed (fig. 2-2).
- (9) By setting the sweep faster than the period of the waveform, it is possible to display just the first part of the waveform. Try various settings of the TIME/DIV, NORMAL AND DELAYING TRIGGERING LEVEL, and NORMAL AND DELAYING TRIGGERING SLOPE controls to obtain the best presentation.
- (10) If the trace is not stable with the HF STAB control in the NORM position, rotate the control until the trace stabilizes.

c. *Use of the PULL X10 Switch.* Pull out the PULL X10 switch to magnify the horizontal amplitude of the display 10 times. Adjust the horizontal POSITION control as required to bring the desired portion into view.

d. *Triggering Instructions for Delaying Sweep.*

Note. Review the general triggering information in paragraph a above before proceeding with the following:

(1) *Triggered-strobe operation.* When the DISPLAY LOGIC switch is in the TRIG-STROBE position, the normal sweep will display the trace, and the strobe circuit (controlled by the delaying sweep) will brighten the trace. If the delaying sweep is faster than the normal sweep speed, only part of the trace is brightened. If the delaying sweep is very much faster the brightened portion of the trace is only a spot, which makes a useful marker when the delaying sweep is used for time measurements (par. 2-12 below). To operate in the triggered-strobe mode:

- (a) Perform the oscilloscope starting procedure (par. 2-7).
- (b) Connect the probe to the signal source. (Connect both probes for dual-trace operation.)
- (c) Set the DISPLAY LOGIC switch to the TRIG-STROBE position.
- (d) Use the procedures in paragraph b to stabilize the normal sweep which displays the trace.
- (e) To adjust the length of the brightened portion of the trace, pull out the DELAYED SWEEP-PULL TO UNLOCK switch and rotate it. Increasing the delaying sweep speed shortens the brightened portion; decreasing the sweep speed lengthens it.

(f) Set the locking lever to the left to unlock the DELAY VERNIER control and dial. Move the brightened portion of the trace to the right or left by rotating the DELAY VERNIER control. The dial setting is the horizontal distance in graticule divisions from the start of the trace to the start of the brightened portion. Read whole numbers of graticule divisions in the window at the top of the dial, fractions of divisions to .02 on the dial face. Move the locking lever to the right to lock the DELAY VERNIER control and dial.

(2) *Triggered-delayed operation.* When the DISPLAY LOGIC switch is set to TRIG-DLY'D, the brightened section of the display is expanded to full scale. The ratio of the normal sweep rate to the delayed sweep rate determines the amount of horizontal expansion or magnification. The magnification ratio can be expressed as the normal sweep rate (TIME DIV) divided by the delayed sweep rate (TIME/DIV). For example, assume the normal sweep rate is set to 1 millisecond, and the delayed sweep rate is set to 1 μsec. The brightened portion of the sweep is therefore magnified horizontally 1,000 times. To operate in the triggered-delayed mode:

(a) Display the entire waveform with the brightened portion (strobe) as described in (1) above.

(b) Using the DELAYED SWEEP-PULL TO UNLOCK switch and the DELAY VERNIER control, adjust the length of the brightened Portion of the delayed sweep, and select the portion of the normal sweep waveform you wish to observe.

(c) Set the DISPLAY LOGIC switch to TRIG-DLY'D. The brightened portion (delayed sweep) of the trace will spread across the entire screen.

(3) *Armed-strobe operation.* In this mode the armed multivibrator blocks all triggers to the delayed sweep circuit until after the selected delay time is over. After the selected delay, the first trigger applied will fire the delayed sweep. To operate in the armed strobe mode:

(a) Display the entire waveform with the normal sweep (b above).

(b) Set the DISPLAY LOGIC switch to ARM-STROBE.

(c) Pull the DELAYED SWEEP-PULL TO UNLOCK switch and set it for the desired length of the brightened portion.

(d) Operate the delayed sweep trigger SLOPE switch and LEVEL control to select the trigger point for the brightened portion. Since this is an armed mode of operation for the delayed sweep, the brightened portion will move from one trigger point to the next as the DELAY VERNIER control is rotated.

(4) *Armed-delayed operation.* When the DISPLAY LOGIC switch is set to ARM-DLY'D, the brightened section of the display is expanded to full screen. The magnification ratio is computed exactly as described in (2) above. To operate in the armed-delayed mode:

(a) Display the entire waveform with the normal sweep (b above).

(b) Set the DISPLAY LOGIC switch to ARM-STROBE, and set up the delayed sweep controls for armed-strobe operation (3) above.

(c) Pull the DELAYED SWEEP-PULL TO UNLOCK switch and set it for the desired length of the brightened portion.

(d) Set the DISPLAY LOGIC switch to ARM-DLY'D. The brightened portion (delayed sweep) of the trace will spread across the entire screen.

e. *Horizontal Amplifier Operation.* To use the delaying sweep plug-in as a horizontal amplifier (example-amplifying an external sweep), apply a signal to the EXT TRIG X AMP connector. Set the coupling switch in accordance with the signal frequency (AC or DC), the DISPLAY LOGIC switch to X AMP, and adjust the X AMP ATTN control as desired. For additional horizontal gain, pull the PULL X10 (POSITION) control out.

2-11. Voltage Measurements (Peak-To-Peak Voltages)

a. To measure the voltage between any two points on the displayed waveform, set the NORM-INVERT (AC-DC-GND) switch to AC. In this position the input signal is displayed on the screen without its dc component. However, if the frequency of the input signal is less than 10 (16) cps, set the NORM-IN-VERT switch to DC to avoid errors.

b. To measure the peak-to-peak voltage of the displayed waveform:

(1) Measure the vertical deflection in graticule divisions from the positive peak to the negative peak of the displayed waveform.

(2) Multiply the vertical dimension found in step (1) by the setting on the VOLTS/DIV switch to obtain the indicated voltage.

(3) If a probe is also being used, multiply the indicated voltage found in step (2) by the probe's attenuation factor to obtain the peak-to-peak voltage.

2-12. Time Measurements

a. *Time Measurements Using Scale Divisions.*

(1) Set the TIME DIV vernier control to CAL.

(2) Measure the horizontal distance in graticule divisions between the two points on the displayed waveform whose time interval you wish to find.

(3) Multiply the horizontal dimension found in step (2) by the setting on the TIME/DIV switch to obtain the time interval.

b. *Repetition Rate of Frequency Using Scale Divisions.*

(1) Measure the horizontal distance in graticule divisions of one complete cycle of the display. (This includes both positive and negative portions for an ac signal.)

(2) Multiply the horizontal dimension found in step (1) by the setting on the TIME/DIV switch.

(3) Take the reciprocal of the product obtained in step (2)(that is, divide it into one). The result is the frequency or repetition rate in cycles per second on the display:

$$\text{Cycles/second} = \frac{1}{\text{Time (seconds)}}$$

c. *Pulse Width Measurements Using Scale Divisions.*

(1) Set the TIME/DIV vernier control to CAL.

(2) Set the DISPLAY LOGIC switch to TRIG-STROBE.

(3) Pull out the DELAYED SWEEP-PULL TO UNLOCK switch and rotate it and the DELAY VERNIER control until the desired pulse is brightened as shown in figure 2-3A.

(4) Set the DISPLAY LOGIC switch to TRIG-DLY'D.

(5) Measure the horizontal distance in graticule divisions from the 50 percent point on the leading edge of the pulse (rise of the pulse) to the 50 percent point on the trailing edge of the pulse (fall of the pulse) as shown in figure 2-3B.

(6) Multiply the horizontal distance found in step (5) by the setting of the DELAYED SWEEP-PULL TO UNLOCK switch to obtain the width of the pulse.

d. *Pulse Width Measurements Using the DELAY VERNIER Control.*

(1) Set the TIME/DIV vernier control to CAL.



A. TRIGGERED STROBE DISPLAY

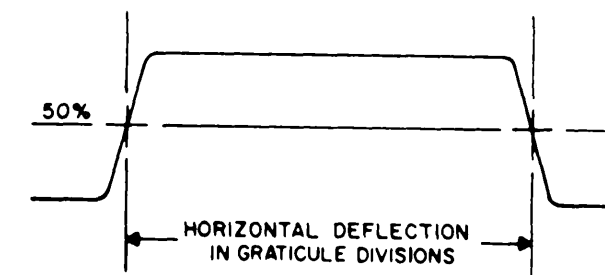

B. TRIGGERED DELAYED DISPLAY

ORD G350282

Figure 2-3. Pulse width measurements using scale divisions.

- (2) Set the DISPLAY LOGIC switch to TRIG-STROBE.
- (3) Set the TIME DIV switch until several cycles of the signal appears on the screen.
- (4) Pull out the DELAYED SWEEP/PULL, TO UNLOCK switch and rotate it until the intensified segment is reduced to a small bright dot.
- (5) Rotate the DELAY VERNIER control until the bright spot is at the 50 percent point of the leading edge of the desired pulse as shown in figure 2-4A.
- (6) Record the DELAY VERNIER control dial reading.
- (7) Rotate the DELAY VERNIER control until the bright spot is at the 50 percent point of the trailing edge of the desired pulse as shown in figure 2-4B.
- (8) Record the DELAY VERNIER control dial reading.
- (9) Subtract the dial reading obtained in step (6) from the dial reading obtained in step (8).
- (10) Multiply the difference of the two dial readings by the setting of the TIME/DIV switch. The product is the pulse width.

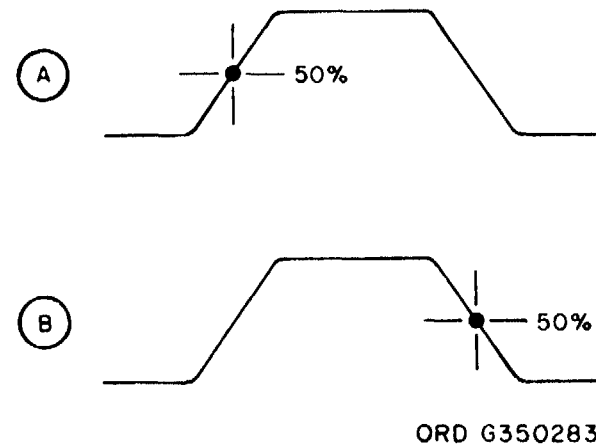

Figure 2-4. Pulse width measurements using the DELAY VERNIER control

2-13. Phase Shift Measurements

To determine the phase difference between two sine-wave signals proceed as follows:

- a. Measure the distance between the two sine waves displayed on the CRT screen as described in steps (1) through (8) below.
 - (1) Apply one of the sine-wave signals to the channel A input and the other to the channel B input of the dual trace plug-in.
 - (2) Set up the delaying sweep plug-in for externally triggered normal sweep operation (par. 2-10). Use the sine-wave signal source that is applied to the channel A input as the external trigger source.
 - (3) Set the MODE switch to ALT.
 - (4) Adjust the TIME/DIV switch until a couple of cycles of the display appear on the screen.
 - (5) Adjust the POSITION controls on the dual trace plug-in until the positive portion of the sine wave above the horizontal graticule center line is equal to the negative portion of the signal below the line.
 - (6) Adjust the POSITION control on the delaying sweep plug-in until the positive slope of one of the signals starts at the first left side vertical graticule line.
 - (7) Measure the horizontal distance of one cycle of the sine-wave signal that starts at the first left side vertical graticule line as shown in figure 2-5. Call this distance A.

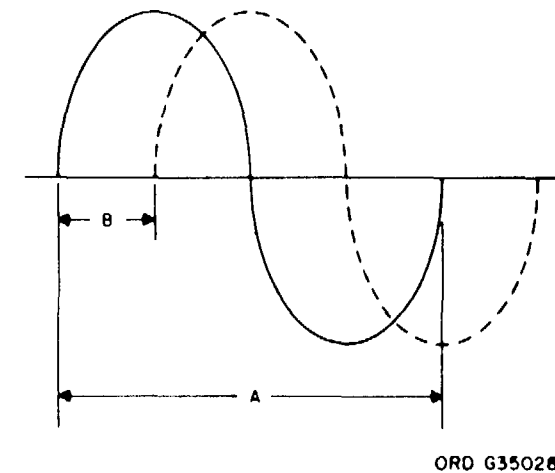

Figure 2-5. Phase shift measurements.

- (8) Measure the horizontal distance between the start of one of the sine-wave signal to the start of the other (Fig. 2-5). Call this distance B.
 - b. Calculate the phase shift as follows:
 - (1) Divide the distance (B) found by step a(8) by the distance (A) found in step a(7).
 - (2) Multiply the quotient thus obtained by 360 degrees. The resultant is the phase difference between the two sine-wave signals:

$$\text{Phase-shift-difference} = \phi = \frac{B}{A} \times 360^\circ$$

Section IV. CHECK PROCEDURES

Caution: To prevent damage to the equipment, assure that the power is off before inserting plug-in units into, or removing these units from the main frame.

2-14. General

This section contains the organizational check procedures for checking the operation of the oscilloscope. Two tables are provided: the first, table 2-4, is to be performed before operation and monthly; the second, table 2-5, pertains to the dual trace plug-in 79-02A only, and is to be performed when trouble is suspected (nonperiodic).

2-15. Oscilloscope Check (Fig. 2-6)

This paragraph covers the step-by-step procedure required to check the operation of the oscilloscope. The steps within each table are to be performed in the sequence given. The procedure is presented in tabular form and is explained in the following sample table. Notice that each indentation for test contained in the table lines up with the appropriate table heading. Under the heading Operation are the instructions (e.g. Check Normal Sweep) as well as a listing of those operations that must be performed in order to obtain a normal indication. Under the heading Normal indication is given what that normal indication shall be, and under Corrective procedure is described the corrective action that is to be taken to restore the oscilloscope to its proper operating condition.

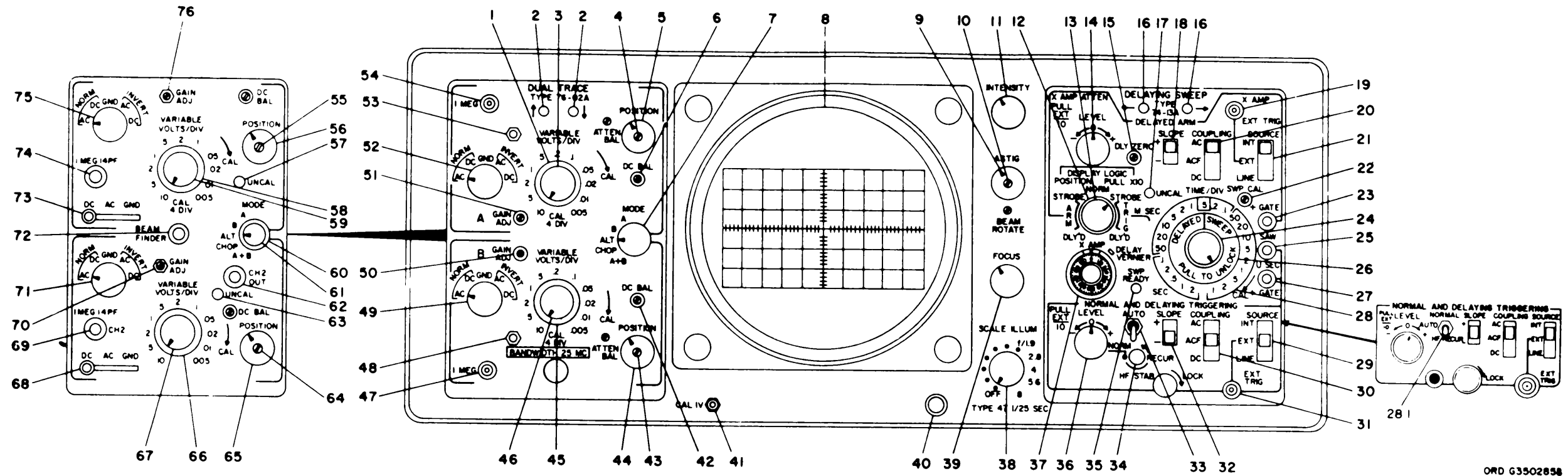

ORD G3502858

- | | | | |
|--|--|---|---|
| <p>1—VOLTS/DIV switch (channel A)
2—Vertical beam position indicators
3—VARIABLE vertical amplitude control (channel A)
4—ATTEN BAL control (channel A)
5—POSITION (vertical) control (channel A)
6—DC BAL control (channel A)
7—MODE switch
8—Cathode-ray tube
9—ASTIG control
10—BEAM ROTATE control
11—INTENSITY control
12—DISPLAY LOGIC switch
13—POSITION (horizontal) control and PULL X10 switch
14—LEVEL control, X AMP ATTEN control, and PULL EXT 10 switch
15—DLY ZERO control
16—Horizontal beam position indicators
17—UNCAL indicator
18—SLOPE switch (delayed sweep)
19—EXT TRIG—X AMP connector (delayed sweep)</p> | <p>20—COUPLING switch (delayed sweep)
21—SOURCE switch (delayed sweep)
22—SWP CAL control
23—+ GATE connector (delayed sweep)
24—Sweep vernier control
25—SAW connector (normal sweep)
26—DELAYED SWEEP-PULL TO UNLOCK switch
27—+ GATE connector (normal sweep)
28—TIME/DIV switch
28.1—NORMAL-AUTO-HF RECUR switch (newer version 74-13A)
29—SOURCE switch (normal sweep)
30—COUPLING switch (normal sweep)
31—EXT TRIG connector (normal sweep)
32—SLOPE switch (normal sweep)
33—AUTO-NORM switch (older version 74-13A)
34—HF STAB control and NORM-RECUR switch (older version 74-13A)
35—SWP READY indicator
36—LEVEL control and PULL EXT 10 switch
37—DELAY VERNIER control</p> | <p>38—SCALE ILLUM control and power switch
39—FOCUS control
40—Power-on indicator
41—CAL 1V connector
42—DC BAL control (channel B)
43—ATTEN BAL control (channel B)
44—POSITION (vertical) control (channel B)
45—VOLTS/DIV switch (channel B)
46—VARIABLE vertical amplitude control (channel B)
47—1 MEG input connector (channel B)
48—Ground connector
49—NORM-INVERT switch (channel B)
50—GAIN ADJ control (channel B)
51—GAIN ADJ control (channel A)
52—NORM-INVERT switch (channel A)
53—Ground connector
54—1 MEG input connector (channel A)
55—DC BAL control (channel 1)
56—POSITION (vertical) control (channel 1)</p> | <p>57—UNCAL indicator (channel 1)
58—VOLTS/DIV switch (channel 1)
59—VARIABLE control (channel 1)
60—MODE switch
61—TRIGGER switch
62—CH2 OUT connector
63—UNCAL indicator (channel 2)
64—DC BAL control (channel 2)
65—POSITION (vertical) control (channel 2)
66—VOLTS/DIV switch (channel 2)
67—VARIABLE control (channel 2)
68—DC-AC-GND (input selector) switch (channel 2)
69—1 MEG 14 PF (input) connector (channel 2)
70—GAIN ADJ control (channel 2)
71—NORM-INVERT switch (channel 2)
72—BEAM FINDER switch
73—DC-AC-GND (input selector) switch (channel 1)
74—1 MEG 14 PF (input) connector (channel 1)
75—NORM-INVERT switch (channel 1)
76—GAIN ADJ control (channel 1)</p> |
|--|--|---|---|

Figure 2-6. Oscilloscope front panel controls and indicator.

Table SAMPLE TABLE

Step	Operation	Normal Indication	Corrective procedure
1.	Check (Step Name)		
	(OPERATION)		Sequence and step name of the specific check. Sequential operations required to obtain an indication.
	a.		
	b.	(NORMAL INDICATION)	Normal system or circuit responses. (CORRECTIVE PROCEDURES) Adjustment listing if applicable. Reference to functional schematics.

Table 2-4. Oscilloscope Check Procedures

Step	Operation	Normal Indication	Corrective procedure
Note 1. The numbers in parentheses are keyed to components located in figure 2-6.			
Note 2. An oscilloscope warm-up period of 20 minutes should precede these checks.			
1.	Check Normal Sweep.		
	a. Set the INTENSITY control (11) fully counterclockwise.		
	b. Set the ASTIG control (9) to Midrange.		
	c. Set the FOCUS control (39) to midrange.		
	d. Set the SCALE ILLUM control (38) to midrange.		
	The power-on indicator lamp (40) illuminates.		
	e. Set the TIME/DIV switch (28) to 1 mSEC for 400-Hz line source; or 5 mSEC for 60-Hz line source.		
	f. Set the DELAYED SWEEP-PULL TO UNLOCK switch (26) to 1 mSEC for 400-Hz line source; or 5 mSEC for 60-Hz line source.		
	g. Set the TIME/DIV sweep vernier control (24) fully clockwise (in the detent).		
	h. Set the SOURCE switches (21 and 29) to LINE.		
	i. Set the COUPLING switches (20 and 30) to AC.		
	j. Unlock the DELAY VERNIER control (37), and set this control to 0 (window and dial).		
	k. Set the AUTO-NORM switch (33)(older version 74-13A) or NORMAL-AUTO-HF-RECUR switch (28.1)(newer version 74-12A) to NORMAL.		
	l. Set the LEVEL controls (14 and 36) to 0.		
	m. Set the DISPLAY LOGIC switch (12) to NORM.		
	n. Set the POSITION controls (5, 13, and 44)(or 13, 56, and 65) to midrange.		
	o. Set the NORM-INVERT switches (49 and 52) to NORM AC.		
	p. Set the VOLTS/DIV switches (1 and 45)(or 58 and 66) to any position except CAL.		
	q. Set the VARIABLE controls (3 and 46)(or 59 and 67) to CAL (in the detent).		
	r. Set the MODE switch (7) to A, or MODE switch (60) to CH1.		
	s. Rotate the INTENSITY control (11) clockwise.		
	A horizontal trace line is present.		
			Adjust LEVEL control (36). Adjust the POSITION controls (5 and 13). Refer to the delaying sweep plug-in functional schematic (Fig. 4-5, older

Table 2-4. Oscilloscope Check Procedures-Continued

Step	Operation	Normal Indication	Corrective procedure
			version 74-13A or Fig. 3-14, newer version 74-13A). Check normal sweep circuit of the delaying sweep plug-in.
	t. Adjust the FOCUS, ASTIG, and INTENSITY controls (39, 9, and 11) to (obtain a sharp horizontal trace line.		
	A sharp trace line can be obtained.		
			Adjust the PAT CORR control at the rear of the main frame.
	The trace line is alined with the CRT overlay.		
			Adjust the BEAM ROTATE control.
2.	Check Calibration Signal		
	a. Set the channel A VOLTS/DIV switch (1 or 58) fully counterclockwise to CAL.		
	A 4-division peak-to-peak square wave is present.		
			Center the waveform on the CRT with the POSITION control (5 or 56). Adjust the GAIN ADJ control (51 or 76) if the square wave is other than 4 divisions in amplitude. Adjust the SWP CAL control (22) if the pulse repetition time (prt) is not 2.5 divisions (400-Hz line source) or 3.3 divisions (60-Hz line source). Refer to the power supply functional schematic (figure 4-3). Check the low-voltage power supply on the main frame. Refer to the dual trace plug-in 76-02A or the dual trace plug-in 79-02A functional schematic (figure 4-4 or 4-4.1, respectively). Check the input voltage attenuator circuit in the dual trace plug-in (76-02A or 79-02A). Refer to the delaying sweep plug-in functional schematic (Fig. 4-5 or 3-14). Check the normal sweep circuit of the delaying sweep plug-in.
	b. Set the channel A NORM-INVERT switch (52 or 75) to INVERT AC.		
	A 4-division square wave is present.		
			Refer to the dual trace plug-in functional schematic (Fig. 4-4 or 4-4.1).
	c. Set the channel B VOLTS/DIV switch (45 or 66) to CAL and the MODE switch (7 or 60) to B (or CH2).		
	A 4-division square wave is present.		
			Adjust the GAIN ADJ control (50 or 70).

Table 2-4. Oscilloscope Check Procedures-Continued

Step	Operation	Normal Indication	Corrective procedure
			Refer to the dual trace plug-in functional schematic (Fig. 4-4 or 4-4.1).
d.	Set the channel B NORM-INVERT switch (49 or 71) to INVERT (or INVERT AC). A 4-division square wave is present.		
e.	Set the MODE switch to A (or CH1), and the NORM-INVERT switch to NORM (or NORM AC).		Refer to the dual trace plug-in functional schematic (Fig. 4-4 or 4-4.1).
3.	Check the X10 Probes.		
a.	Connect one X10 probe to the channel A 1 MEG connector (54) and the other X10 probe to the channel B 1 MEG connector (47)(or CH1 1 MEG 14PF and CH2 1 MEG 14PF, 74 and 69, respectively).		
b.	Set the channel A and channel B VOLTS/DIV switches to .02 (or 0.2 and PULL X10).		
c.	Connect the channel A probe tip to the CAL IV connector (41). A 5-division peak-to-peak square wave is present.		Center the waveform on the CRT with the channel A POSITION control (5 or 56) if necessary. Rotate the body of the probe if the square wave is distorted (overshoot or undershoot). Perform the probe set-up procedure (par. 2-8a). Refer to par. 2-7.
d.	Set the MODE switch to B (or CH2).		
e.	Repeat step c for the channel B probe.		
f.	Set the MODE switch to A (or CH1).		Center the waveform on the CRT with the Channel B POSITION control (44 or 65) if necessary.
g.	Set the channel A and channel B VOLTS/DIV switches to CAL.		
4.	Check Triggered-Strobe Sweep.		
a.	Pull the DELAYED SWEEP-PULL TO UNLOCK switch (26), and rotate it until the white scribe mark is alined with the .5 mSEC position. (The cutout of the TIME/DIV switch plastic skirt should still be at the initial setting.)		
b.	Set the DISPLAY LOGIC switch to TRIG-STROBE. A small portion of the square-wave signal is brighter than the rest of the waveform.		Adjust the DELAY VERNIER control (37). Refer to the delaying sweep plug-in functional schematic (Fig. 4-5 or 3-16). Check delayed sweep circuit of the delaying sweep plug-in.

Table 2-4. Oscilloscope Check Procedures-Continued

Step	Operation	Normal Indication	Corrective procedure
5.	Check Triggered Delayed Sweep.		
a.	Adjust the DELAY VERNIER control (37) until the strobe (brightened portion) covers the leading edge of the waveform.		
b.	Set the DISPLAY LOGIC switch to TRIG-DLY'D. The portion of the waveform previously covered by the strobe is not on the screen, horizontally expanded or magnified 5 times (10 divisions).		Refer to the delaying sweep plug-in functional schematic (Fig. 4-5 or 3-18). Check delayed sweep circuit of the delaying sweep plug-in.
	Note. It may be necessary to slightly adjust the DELAY VERNIER control to see the leading edge of the waveform.		
6.	Check Delay Vernier Control.		
a.	Set the DELAYED SWEEP-PULL TO UNLOCK switch (26) to 0.2 mSEC (for 400-Hz source); 1 mSEC for 60-Hz source.		
b.	Set the DELAY VERNIER control to 0 (on both the window and knob skirt).		
c.	Set the DISPLAY LOGIC switch to TRIG-STROBE.		
d.	Set the DELAY VERNIER control to 4 (window)(on the skirt). The 2-division waveform portion between the 4th and 6th divisions is brighter than the remainder of the presentation.		Refer to the delaying sweep plug-in functional schematic (Fig. 4-5 or 3-16). Check delay pick-off circuit of the delaying sweep plug-in.
7.	Check Armed-Strobe Sweep.		
a.	Set the DELAYED SWEEP-PULL TO UNLOCK switch to 5 mSEC.		
b.	Set the DISPLAY LOGIC switch to ARM-STROBE. The strobe (brightened segment) appears on the leading edge of the waveform. The SWP READY indicator lamp (35) flickers.		Refer to the delaying sweep plug-in functional schematic (Fig. 4-5 or 3-18). Check delayed sweep circuit of the delaying sweep plug-in.
8.	Check Armed-Delayed Sweep.		
a.	Set the DISPLAY LOGIC switch to ARM-DLY'D. The strobe portion (leading edge of the waveform) is now present, horizontally expanded or magnified 5 times. The SWP READY indicator lamp continues to flicker.		Refer to the delaying sweep plug-in functional schematic (Fig. 4-5 or 3-18). Check delayed sweep circuit of the delaying sweep plug-in.
b.	Set the channel A VOLTS/DIV switch to .02 (or .2 and PULL X10).		
c.	Set both SOURCE switches (21 and 29) to INT.		
d.	Rotate the LEVEL control (36) to either extreme.		

Table 2-4. Oscilloscope Check Procedures-Continued

Step	Operation	Normal Indication	Corrective procedure
		The SWP READY indicator lamp (35) illuminates.	Refer to the delaying sweep plug-in functional schematic (Fig. 4-5 or 3-18).
e.	With the LEVEL control (36) near either extreme, touch the probe tip to the CAL IV output connector. A single trace appears momentarily on the screen.		
		The SWP READY indicator lamp extinguishes.	Refer to the delaying sweep plug-in functional schematic (Fig. 4-5 or 3-18). Check delayed sweep circuit of the delaying sweep plug-in.
f.	Set the LEVEL control (36) to 0.		
9.	Check Attenuator Balance.		
a.	Set the DISPLAY LOGIC switch to NORM.		
b.	Set the SOURCE switches to LINE.		
c.	Adjust the channel A POSITION control (5 or 56) until the trace rests on the graticule centerline.		
d.	Set the channel A VOLTS/DIV switch to positions .055 through 10 or .1 through 20).		
		The trace remains in the same vertical position as in c above for each of the switch settings.	
e.	Set the MODE switch to B (or CH2).		
f.	Repeat steps c and d for channel B.		
10.	Check Vertical Variable Controls.		
a.	Set the MODE switch to A (or CH1).		
b.	Set the channel A VOLTS/DIV switch to CAL.		
c.	Rotate the channel A VARIABLE control (3 or 59) fully counterclockwise.		
		The amplitude of the waveform appearing on the screen decreases.	Center the waveform on the CRT with the channel A POSITION control if necessary. Refer to the dual trace plug-in functional schematic (Fig. 4-4 or 4-4.1).
d.	Repeat steps h and c for channel B.		
11.	Check Alternate Mode Operation.		
a.	Rotate both the channel A and channel B VARIABLE controls (3 and 46 or 59 and 67) to midrange.		
b.	Set the, MODE switch to ALT.		
		Two flickering waveforms are present on the screen.	Adjust the vertical POSITION controls (5 and 44 or 56 and 65) to separate the two waveforms.

Table 2-4. Oscilloscope Check Procedures-Continued

Step	Operation	Normal Indication	Corrective procedure
			Refer to the dual trace plug-in functional schematic (Fig. 4-4 or 4-4.1). Check the electronic switch or blanking multivibrator of the dual trace plug-in.
12.	Check Chop Mode Operation.		
	Set the MODE switch to CHOP.		
		The two waveforms appearing on the screen are chopped.	Refer to the dual trace plug-in functional schematic (Fig. 4-4 or 4-4.1). Check the electronic switch or the blanking multivibrator circuits of the dual trace plug-in.
13.	Check A + B Mode Operation.		
a.	Adjust both of the vertical POSITION and VARIABLE controls until the waveforms are superimposed and are two divisions in amplitude.		
b.	Record the amplitude of the superimposed waveform.		
c.	Set the MODE switch to A + B (or ADDED).		
		The amplitude of the square-wave display doubles.	Center the waveform on the CRT with either the channel A or channel B POSITION controls if necessary. Refer to the dual trace plug-in functional schematic (Fig. 4-4 or 4-4.1). Check the electronic switch circuit of the dual trace plug-in.
d.	Set the channel B NORM-INVERT switch (49 or 71) (and the AC-DC-GND switch-68) to INVERT AC.		
		The two signals cancel each other and a straight line (trace line) appears on the screen.	Center the display on the CRT with either the channel A or channel B POSITION controls if necessary. Refer to the dual trace plug-in functional schematic (Fig. 4-4 or 4-4.1)

Table 2-5. Dual race Plug-In 79-02A, Check Procedures (Nonperiodic)
(Fig. 5-13.1 and 5-13.2)

Step	Operation	Normal Indication	Corrective procedure
1.	Establish the check condition. a. Energize the oscilloscope in accordance with par. 2-7. b. Set the CH1 and CH2 controls as follows: VOLTS/DIV 0.1 VARIABLE CAL , X1 (pushed in) NORM-INVERT NORM		
2.	Check adjustment of the gas compensation resistors. a. While observing the trace, set the DC-AC-GND switch for CH1 to GND, to AC, and again to GND. There is no visible movement of the trace on the CRT. Adjust the GAS COMP 1 resistor. b. Set the MODE selector switch to CH2. While observing the trace, set the DC-AC-GND switch for CH2 to GND, to AC, and again to GND. There is no visible movement of the trace on the CRT. Adjust the GAS COMP 2 resistor.		
3.	Check adjustment of the DC balance controls. a. Adjust the CH2 POSITION control to position the trace behind the center grid line. While watching the trace, rotate the CH2 VARIABLE control throughout its range. Vertical movement of the trace is less than $\pm 1/16$ inch. (1) Adjust the CH2 DC BAL control. Repeat <i>a</i> and <i>b</i> above. (2) Set the CH2 GAIN ADJ control fully clockwise and set the DC BAL control to the center of its range. (3) Readjust the CH2 POSITION control as necessary to center the trace. (4) While rotating the CH2 VARIABLE control through its range, adjust the DC BAL 2 control to minimize shifting of the trace. (5) Set the CH2 VOLTS/DIV switch to CAL. (6) Adjust the CH2 DIODE LEVEL control for a maximum amplitude wave-shape. (7) Reset the VOLTS/DIV switch to 0.1. (8) While rotating the CH2 VARIABLE control throughout its range, adjust the DC BAL 2 control to minimize shifting of the trace. (9) Repeat <i>a</i> and <i>b</i> above. c. Set the MODE switch to CH1, and adjust the CH1 POSITION control to position the trace behind the center grid line.		

Table 2-5. Dual Trace Plug-in 79-02A. Check Procedures (Nonperiodic)
(Fig. 5-13.1 and 5-13.2) --Continued

Step	Operation	Normal Indication	Corrective procedure
	d. While watching the CRT trace, rotate the CH1 VARIABLE control throughout its range. Vertical movement of the trace is less than $-1/16$ inch.		Repeat <i>b</i> (1) through <i>b</i> (8) above, substituting 1 for 2 wherever it appears in channel and control designators.
4.	Check chopped operation. a. Set the chop rate switch to 100 KC. b. Set the MODE switch to CHOP, and the TIME/DIV switch (delayed sweep plug-in unit) to 5 μ sec. Adjust the POSITION controls so that the trace appears as a broken line. The width of each dark space (blanked area) between segments of the trace does not exceed 3 divisions on the CRT overlay. The switching transients (bumps or dips in the trace at the start or end of a trace segment) are blanked.		Refer to figure 4-4.1.
	c. Set the chop rate switch to 1 MC and the TIME/DIV switch to 0.5 μ sec. The width of each dark space (blanked area) does not exceed 3 divisions on the CRT overlay. The switching transients are blanked.		Refer to figure 4-4.1.
5.	Check amplifier balance. a. Set the controls as follows: Dual trace plug-in 79-02A DC-AC-GNC (CH1)..... GND MODE switch..... CH1 VOLTS/DIV (CH1)..... 0.1 VARIABLE (CH1) CAL, X1 (Pushed in) Delaying sweep plug-in TIME/DIV0.5° sec. b. Switch the CH1 NORM-INVERT switch to INVERT, and then to NORM. There is no visible movement of the CRT. (1) Adjust the INV BAL 1 control. (2) Repeat <i>b</i> to check the adjustment. (3) Refer to figure 4-4.1. c. Set the MODE switch to CH2, and repeat <i>b</i> above, using the CH2 NORM-INVERT switch and the INV BAL 2 control.		

Table 2-5. Dual Trace Plug-in 79-02A. Check Procedures (Nonperiodic)--Continued

Step	Operation	Normal Indication	Corrective procedure
5.	Check amplifier balance-Continued.		
	Note. A voltmeter with a sensitivity of at least 20,000 ohms per volt is required for steps 6 through 11.		
6.	Set the X10 amplifier dc output level.		
	Note. The X10 amplifier gain level is misset while performing step 6. This gain level will be correctly set when performing step 8.		
	a. Set CH1 X10 cal control R9254 fully counterclockwise.		
	b. Connect voltmeter, adjusted to measure 50 volts DC, between the collectors of Q9211 and Q9212, with the positive lead connected to Q9211. Use the polarity switch on the voltmeter as necessary to measure the voltage. The voltmeter indicates zero volts.		Adjust the CH1 POSITION control.
	c. Disconnect the common voltmeter lead from Q9212 and connect to a ground bus.		
	d. Note the position of the trace, and note the indication on the voltmeter.		
	e. Pull the CH1 VARIABLE control to the PULL X10 position and reposition the trace to, the position noted in <i>d</i> above. The voltmeter indicates the same value as noted in d above.		Adjust CH1 X10 level control
	f. Disconnect the voltmeter and push in the CH1 VARIABLE control.		
	g. Set CH2 X10 cal control R9454 fully counterclockwise.		
	h. Connect the voltmeter between the collectors of Q9411 and Q9412 with the positive lead connected to Q9411. The voltmeter indicates zero volts.		Adjust the CH2 POSITION control.
	i. Repeat <i>c</i> through <i>f</i> above, using CH2 controls and CH2 X10 level control R9463.		
	j. Disconnect the voltmeter.		
7.	Check the output current adjustment.		
	a. Check that switch settings are established as follows: MODE switch..... CH2 TRIGGER switchNORM		
	b. Connect a voltmeter, adjusted to measure 100 volts DC, between the collectors of Q9511 and Q9514, with the negative lead connected to Q9511. The voltmeter indicates zero volts.		Adjust the CH2 POSITION control.
	Note. c through e below are preliminary settings. Refer to f below for the final setting.		
	c. Disconnect the positive lead for the voltmeter from Q9514 and connect it to +100v test connector TP1101 on the main frame. The voltmeter indicates +15 volts.		

Table 2-5. Dual Trace Plug-in 79-02A. Check Procedures (Nonperiodic)--Continued

Step	Operation	Normal Indication	Corrective procedure
7.	Check the output current adjustment-Continued.		
	d. Disconnect the negative lead for the voltmeter from Q(9511 and connect it to the collector of Q9514. The voltmeter indicates + 15 volts.		Adjust the OUT CUR ADJ control.
	e. Connect the voltmeter between the collector of Q9511 and the + 10v bus. The voltmeter indication deviates from +15 volts by an amount equal and opposite to that established in the corrective procedure of d above.		Readjust the OUT CUR ADJ control to reduce the error by one half (Example-the voltmeter indicates 14 volts; adjust the OUT CUR ADJ control for an indication of 14.5 volts.)
	f. Repeat <i>d</i> and <i>e</i> above until the measured voltages deviate from + 15v by an equal and opposite amount.		Readjust the OUT CUR ADJ control.
	g. Disconnect the voltmeter.		
8.	Perform the X10 amplifier gain adjustments.		
	a. Perform the procedures of table 2-4, step 2.		
	b. Set controls as follows: VARIABLE control (CH1 and CH2.....CAL, X1 (pushed in) DC-AC-GND switch (CH1 and CH2.....AC TRIGGER switchNORM MODE switch..... CH1		
	c. Apply a signal with an amplitude of between 1 and 10 volts and a frequency of 50 to 400 cycles (a filament voltage will be satisfactory) to the CH1 MEG 14 PF connector.		
	Note. If a signal which can be controlled in amplitude is available, adjust the signal level instead of the VARIABLE control in d below.		
	d. Adjust the VOLTS/DIV switch and VARIABLE control to obtain deflection of 0.4 divisions on the CRT overlay. Adjust the POSITION controls as necessary to determine that the signal amplitude is correctly set.		
	e. Without disturbing the setting of the VARIABLE control, pull the control to the PULL X10 position.		
	f. Adjust CH1 X10 cal control R9254 to obtain 4 divisions of CRT deflection.		
	g. Repeat <i>c</i> through <i>f</i> above using CH2 correctors and controls, and adjusting CH2 X10 cal control R9454.		
	h. Disconnect the signal source.		
9.	Check the trigger generation circuits dc level.		
	a. Set the TRIGGER switch to NORM and the MODE switch to CH1.		
	b. Connect a voltmeter between J9001-25 and ground.		

Table 2-5. Dual Trace Plug-in 79-02A. Check Procedures (Nonperiodic)--Continued

Step	Operation	Normal Indication	Corrective procedure
9.	Check the trigger generation circuits dc level-Continued. The voltmeter indicates zero volts.		Adjust the NORM TRIG ADJ control.
c.	Set the TRIGGER switch to CH2 ONLY, the MODE switch to CH2, and adjust the CH2 POSITION control to center the trace. The voltmeter indicates zero volts.		Adjust the CH2 ONLY TRIG ADJ control.
10.	Check the CH2 output dc level. Connect a voltmeter between the CH2 OUT connector and ground. The voltmeter indicates zero.		Adjust the CH2 OUTPUT LEVEL ADJ control.

CHAPTER 3
THEORY OF OPERATION

Section I. GENERAL THEORY

3-1. Power Supply

The oscilloscope uses four solid-state, low-voltage regulated supplies and one high-voltage regulated supply for its operation (Fig. 4-1).

a. The low-voltage supplies generate the following voltages: -50, +50, +100, and +200.

Starting with the -50 volt supply, each supply provides a reference level for the next higher supply, somewhat like adding batteries in series. For example, adding the -50 volt supply to the +50 volt supply provides 100 volts.

b. The high-voltage supply generates two voltages: +11,200 volts (nominal) and -1350 volts. The high-voltage circuit consists of a high-voltage oscillator (40 to 60 kc), a high-voltage rectifier (operating as a voltage tripler), and a high-voltage regulator. (The voltage tripler may be vacuum tube rectifiers or solid-state rectifiers depending on the difference among models covered in paragraph 1-5.) The -1350 volt supply uses a half-wave, solid-state, rectifier to produce the negative voltage.

3-2. Dual Trace Plug-in 76-021

Each channel of the dual trace plug-in has its own input connection (Fig. 4-2). These are designated channels A and B. Each channel also has a separate set of switches and controls to provide attenuation or amplification of the signal applied to it. In addition, a common switch permits any one of five signal modes to be displayed.

a. *Attenuation.* The VOLT/DIV selector switch permits the unit to handle a large range of signal voltages. The switch can be set from 0.005 volts per division to 10 volts per division. However, since the probe provides an additional X10 attenuation-and since there are six divisions on the graticule screen-the sampled signal can be any value within a range of about 0.05 volt (one division) to 600 volts (six divisions).

Measurements can be made with probes other than the X10 probe, in which case one division could equal 0.005 volt.

b. *Amplification.* The individual channel preamplifier takes the single-ended input signal, converts it to push-pull, and amplifies the resulting signal.

c. *Mode Selection.* A MODE selection switch controls the dual-channel output, permitting any one of five modes to be displayed. the MODE selection switch operates in conjunction with a conventional bistable multivibrator that functions as an electronic switch.

(1) *A mode.* To display only the signal applied to channel A, the electronic switch is set to one of its two states, cutting off the channel B output.

(2) *B mode.* To display only the signal applied to channel B, the electronic switch is set to its opposite state, cutting off the channel A output.

(3) *Alternate mode.* In this mode the electronic switch is triggered at the start of each horizontal sweep by a pulse that originates in the delaying sweep plug-in. That is, each pulse sets the switch alternately from one state to the other. This cuts off the A channel output during one horizontal sweep and cuts off the B channel output during the next sweep. The A and B channels are thus alternately switched on and off.

(4) *CHOP mode.* In the chop mode, the electronic switch is fired by a blanking multivibrator that produces 1- μ sec pulses at a 60-kc free-running rate. Since the electronic switch is fired at a faster rate than in the alternate mode, individual segments of each channel's output are displayed alternately.

(5) *A + B mode.* For this mode, the operating voltage is removed from the electronic switch, effectively removing it from the circuit. This allows the two channel outputs to be algebraically summed.

d. *Delay Line.* In order to get the sweep started, before the signal being displayed gets to the vertical deflection plates, the signal is picked off for internal triggering, just before it is passed through a delay line. A point on the leading edge of the signal is used to generate the trigger, which starts the sweep.

e. *Vertical Deflection Amplifiers.* Since the output of the delay line is comparatively low, it is sent through a series of amplifier stages before being applied to the vertical deflection plates. These amplifier stages (vertical deflection amplifiers) produce the necessary power to drive the vertical deflection plates.

3-2.1. Dual Trace Plug-in 79-02A

a. *General.* Dual trace plug-in 79-02A (Fig. 4-4.1) consists of two sets of attenuators, two preamplifiers, an electronic switching unit and a common amplifier. One set of attenuators and preamplifiers is provided for channel 1, while the other is provided for channel 2. The electronic switching unit allows outputs from channel 1 and/or channel 2, as selected by the MODE selection switch, and the common amplifier further amplifies the selected video. The frequency response of each channel, in the X1 position of the VARIABLE switch, is 0 to 100 MHz in the DC position of the DC-AC-GND switch, and 16 cps to 100 MHz in the AC position of the switch (between 3 db points). All the amplifiers in each channel are dc coupled to retain the dc component of the input signal.

b. *Attenuators.* With the VARIABLE control set to CAL, accurate, frequency-compensated attenuators (VOLT/DIV) allow selection of deflection sensitivities from 0.1-to 20-volts per division in eight steps. All voltage indications obtained must be multiplied by the attenuation of the probe used to determine the true amplitude.

c. *Preamplifiers.* The preamplifiers are normal push-pull amplifiers. Bias on stages within the preamplifier may be equalized to center the trace, or unbalanced to offset the trace, vertically (POSITION control). The gain of the first stages in either channel may be reduced as desired by adjusting the VARIABLE control. Thus, this control extends the range of the VOLTS/DIV switch to make continuous control from 0.1-to 50-volts/division available. A NORMAL/INVERT switch makes it possible to cross-couple the amplifiers, thus inverting the input signal. Additional sets of amplifiers may be connected by pulling the VARIABLE switch to the X10 position, thus increasing the gain of each channel by a ratio of 10:1.

d. *Switching circuits.* A basic timing oscillator (BTO), a channel switching multivibrator, and a switching amplifier comprise the switching circuits. The basic timing oscillator may be controlled by a trigger from the delayed sweep plug-in (ALT mode), or it may free run at either a 100 kHz or a 1 MHz rate, as selected by an internal switch (CHOP mode). In the ALT and CHOP modes, the basic timing oscillator controls the channel switching multivibrator. In other modes (CH1, CH2, and ADDED), the channel switching multivibrator is set to a fixed state (channel 1, channel 2, or off, respectively). The switching amplifier is controlled by the channel switching multivibrator, and it amplifies the selected signal(s).

e. *Common amplifier.* The common amplifier is a standard push-pull amplifier which amplifies the signal. The output of this amplifier is applied through a CRT termination network to the vertical deflection plates of the CRT.

3-3. Delaying Sweep Plug-In

a. *Triggers.*

(1) Normal and delayed triggers. The sweep can be triggered internally, externally, or by the line voltage (60 Hz, 400 Hz, etc.). These input signals are all processed in the same way, with some point on the leading edge of the signal producing the actual trigger. For normal sweep, an input trigger is needed to produce horizontal deflection.

(2) Automatic trigger. For automatic triggering, no input trigger is needed. The automatic triggering circuit gives a trace on the CRT screen, regardless of whether or not there is an input to the trigger circuit.

b. Normal Sweep. Normal sweep is provided into the horizontal deflection circuit when the DISPLAY LOGIC switch, in the normal and delaying triggering sweep channel (NDT), called the normal sweep channel is set to NORM.

(1) *Sweep gate.* The first trigger-resulting from a voltage level comparison in the trigger circuit-fires the sweep gate multivibrator, producing a negative gate. This gate is fed to a linear sweep generator to start the ramp sweep.

(2) *Linear sweep.* The slope of the sweep signal is set by the particular RC time constant switched in by the TIME/DIV selector switch. The sweep begins to rise at a linear rate and when the ramp voltage reaches a predetermined level, a turn-off trigger resets the sweep gate multivibrator. This causes the ramp to collapse, producing a sweep retrace.

(3) *Lockout output.* The lockout circuit does two things. It uses the sweep feedback (coupled through the turn-off trigger circuit) to keep additional triggers out of the sweep gate multivibrator, and to sustain the collapse time of the sweep, thus allowing full recovery and inhibiting premature triggering.

(4) *Beam gate circuit.* The CRT contains a baffle with an aperture through which the scanning electron beam passes on its way to the phosphor screen. At the top and bottom of this baffle are two plates, and as long as these two plates are kept at the same potential the beam is unaffected. For example, if the inverted sweep gate is clamped to +50 vdc, and +50 vdc is applied to the other plate, the beam gate plates allow the electron beam to go through the aperture during trace time. During retrace, one of the beam gate plates is raised to +125 volts by the beam gate circuit. This 75-volt difference of potential draws the electron beam away from the aperture, thus blanking the screen during retrace.

c. Delayed Sweep. The delayed (armed) sweep channel (DA), called the delayed sweep channel, closely resembles the normal sweep channel. For the normal sweep channel description, the NORM position of the DISPLAY LOGIC switch was described. Now let's consider the other five positions.

(1) *Triggered-strobe.*

(a) In this switch position, a bright segment (strobe) appears to be superimposed over the normal presentation. This illusion is created by using the beam gate plates in the CRT. To do this the normal sweep is routed to the deflection plates through the TRIG-STROBE position of the DISPLAY LOGIC switch.

(b) The normal sweep is also fed to a comparator trigger circuit. One input to this circuit is a dc reference level, set by the DE-LAY VERNIER control. When the sweep run-up reaches this reference level, the comparator trigger circuit fires, sending a trigger to the delayed-sweep circuit.

(c) The trigger fires the delayed-sweep gate multivibrator. From the multivibrator, one gate output goes to the delayed sweep generator. However, the sweep isn't applied to the CRT deflection plates, but is used to generate a turn-off trigger at the end of the sweep. Meanwhile, the other sweep gate output goes to the strobe circuit.

(d) The CRT beam gate circuit was covered in *b.(4)* above. In the triggered strobe switch position, this circuit works in the same way, except that the potentials are no longer equal. The non-gate level may be about 30 volts, creating a potential between beam gate plates of 20 volts. This 20 volts isn't large enough to completely deflect the beam, but it does deflect it partially. As a result there is a less intense display. When the delayed beam gate (50 volts) is applied, the potential of both plates is the same, permitting the full electron beam to go through the aperture. Since the signal is more intense, the display brightens during this strobe period.

(2) *Triggered-delayed.* In this switch position, only the delayed sweep appears. (The delayed sweep is routed through the DISPLAY LOGIC selector switch, and the normal sweep is terminated.) The circuit performs as described above, except that one output of the sweep gate is differentiated, thus providing a trigger to turn off the normal sweep at the end of the delayed sweep.

(3) *Armed-strobe.* In this switch position the trigger from the comparator trigger circuit goes only to the armed multivibrator. At this time the input trigger circuit is also enabled.

However, the output of the armed multivibrator prevents all input triggers from firing the delayed-sweep gate multivibrator. When the comparator trigger is applied to the armed multivibrator, it produces an output that allows the next input trigger to fire the delayed-sweep gate multivibrator. This sweep gate is then fed back to reset the armed multivibrator, locking out subsequent input triggers. The sweep gate then goes through the beam gate circuit, to produce strobe effects similar to those described in (1) above.

(4) *Armed-delayed.* In this switch position only the delayed sweep is displayed, as in (2) above. However the delayed sweep is not activated until the comparator output triggers the armed multivibrator, and, as in (3) above, it produces an output that allows the next input trigger to fire the delayed-sweep gate multivibrator.

d. External Sweep. For external sweep, an external signal is injected at the X AMP input instead of the normal or delayed sweep inputs to the horizontal deflection circuit. This permits the use of non-linear signals for the sweep with which we can generate waveforms such as lissajous patterns.

e. Horizontal Deflection Amplifier. The horizontal deflection amplifier functions the same in all sweep modes, including X amplifier only (external sweep). The output from the sweep generators or from the external source is sent through a series of emitter follower and amplifier stages before being applied to the horizontal deflection plates. These stages convert the single-ended input signals (output of the sweep generators) into pushpull signals of sufficient power to drive the CRT deflection plates.

Section II. FUNCTIONAL THEORY-POWER SUPPLY

3-4. Low-Voltage Power Supply, Older 765MH Models (Fig. 4-3)

a. Primary Power. Primary ac power from a convenience outlet is brought into the unit via connector W1001 (sone A1). The unit is turned on by turning the SCALE ILLUM control clockwise, thus closing the contacts of switch S102, and applying the ac voltage to the primary windings of transformers T1001 and T2. SCALE ILLUM control R1002 is also used to control the graticule scale brightness level. If the source is 115 volts, switch S101 is set to the 115V position, connecting the two primary windings of T1001 in parallel. When the source is 230 volts, switch S101 is set to the 230V position, connecting the primary windings in series.

b. Temperature Control. Temperature control is provided by a fan, a heater, and thermal interlock system. If the temperature drops below 41°F, normally open thermal relay S1201 closes, and the heater warms the equipment. If the temperature rises above 68°F, the fan cools the equipment. If the temperature exceeds 190°F, interlock thermal cutout relay S103 opens the ac source. Ac voltage for induction motor in the fan is supplied through power switch S102. With 115/230-volt switch S101 set to 115V, the fan voltage is supplied through temperature switch S1 to one fan connection; and through thermal cutout S103, interlocks J8001-31 and J9001-31 and the 115-volt connection of S101 to phase-shifting capacitors C1 and C2, directly to the fan. With switch S101 in the 230-volt position, the fan is connected in series with one section of transformer T1001 (black and black-red wires), and in parallel with the second section.

c. Low-Voltage Rectification. Four of the (tapped) secondaries of transformer T1001 apply stepped-down ac voltages to four different full-wave rectifiers. Capacitor/resistor network filters the rectified outputs to reduce the ac ripple. These dc voltages are then processed by individual voltage regulators, or where applicable, are routed internally as unregulated voltages.

NOTE

The low-voltage regulators described below are in some MH models. Similar regulators, with different reference designators, are used in MH/F models.

d. *Voltage Regulators.*

(1) *-50 Volts.*

(a) The -50-volt regulator (zones D4, D5) is the master regulator to which all the other regulators in the power supply are referenced. Therefore, if we are to maintain good regulation from the other power supplies, the -50-volt regulator must be accurate.

(b) The main reference source is voltage regulator (gas-filled tube) V101. In normal operation the firing potential of the tube is exceeded, resulting in a constant voltage drop across the tube. Resistor R1038 limits the current through the tube to a value within its operating range. If the output of the -50-volt rectifier varies, the tube current will in turn vary. The variation in current through the tube results in an increased or decreased voltage drop across resistor R1038, thus maintaining the tube's constant voltage characteristic.

(c) This constant voltage is applied to -50V ADJ variable resistor R1041, and to resistors R1039 and R1042 which are all in series, forming a voltage divider across the tube. The wiper of R1041 takes a portion of the constant voltage and applies it to the base of Q114 in the difference amplifier.

(d) The other input to the difference amplifier comes from the rectified output of CR1007-CR1008, which is filtered by C1018 and R1037. The negative output is applied across a voltage divider (R1049, R1048)(zone D15) to ground, and a portion of this fixed voltage drop is applied to the base of Q116 in the difference amplifier. Should the output voltage from the rectifier begin to change, the variation is sensed by the difference amplifier and is applied to error driver (emitter follower) Q115.

(e) Driver Q115 couples the error voltage to the base of emitter follower Q117, which acts as a controlled series element. The series element conducts more or less current, depending on the original variation. By adjusting -50V ADJ variable resistor R1041, you can set the regulated output voltage to exactly -50 volts.

(f) Breakdown diode CR1014 is a protective device. It conducts, shunting the excess current directly to ground, before the breakdown voltage of series-element transistor Q117 is exceeded.

(2) *50 Volts.* The only significant difference between the -50- and 50-volt regulators is that the 50-volt regulator uses an error amplifier (Q112) instead of a difference amplifier. By adjusting +50V ADJ variable resistor R1035 (which is connected to the -50 vdc regulated, reference point, output) to the proper bias for the error amplifier, a condition is set up where any variation in voltage is sensed by the amplifier. The error voltage is then applied through error driver Q111 to series-element transistor Q113. The resulting output is a regulated 50 volts with respect to ground. Breakdown diode CR1013 is a protective device similar to CR1014 described above.

(3) *100 Volts.* The 100-volt regulator is identical to the 50-volt regulator except that its negative terminal is connected to the 50-volt regulated output (zone C6). +100V ADJ variable resistor R1024 is referenced to the -50 volts regulated output (zone D6) and is adjusted for a regulated output of 100 volts.

(4) *200 Volts.* This regulator is similar to those described above, except that the error amplifier uses two transistors (Q104, Q105). The reference voltage, derived from the -50-volt regulated output, is taken from +200V ADJ variable resistor R1015 and applied to the base of Q105. The emitter of Q105 is referenced to 100 volts regulated output via CR1010. The output of Q105 then becomes the reference level for amplifier Q104. A portion of the output voltage is applied to the base of Q104 via voltage divider R1012, R1013. Amplifier Q104 senses any change in voltage and couples it to driver Q103. The output from the driver goes to series element Q106, which compensates for the voltage change by passing more or less current. Notice that the collector current for Q103 and Q106 is supplied by error driver Q101 and series element Q102. These two transistors increase the current capability of the 200-volt regulator, insuring greater stability.

Breakdown diodes CR1009 and CR1011 protect the series-element transistors by conducting when a short circuit occurs.

e. *Calibration Voltage (1V P-P).* A portion of the ac voltage from one of the secondaries of T1001 is applied to R1026 and transistor Q118, which functions as a switch. Q118 saturates when the ac voltage begins to go positive, producing an output that is near ground potential. When the ac voltage swings negative, Q118 immediately cuts off, and resistors R1052, R1053, and R1054 reduce the collector voltage to 1 volt. This fast switching action of Q118 results in a 1-volt peak-to-peak square wave for use in calibrating the oscilloscope (zone C3).

3-5. High-Voltage Supply (Older 765MH Models)

a. *Oscillator.* High-voltage oscillator V202 is a conventional shunt-fed Hartley oscillator which uses transformer T2001 and capacitor C2006 to form a tank circuit. The oscillator generates a 40-kc to 60-kc sine wave, that is stepped up via T2001 and is applied to both the high-voltage rectifier and the -1350-volt half-wave rectifier.

b. *High-Voltage Rectifier.*

(1) *Voltage tripler.* Rectifiers V203, V205, and V206 make up a voltage tripler. (In later models this circuit consist of solid-state diodes CR2050, CR2051, and CR2052).

(a) Looking at figure 3-1.1, assume that the positive half of the sine wave from transformer T2001 is applied to the circuit. Tube V203 is forward-biased and therefore conducts. Capacitor C2020 charges to approximately the peak voltage (E) via V203, as shown by the long-and-short dashed line in the figure.

(b) The positive cycle from T2001 is also applied to tube V206 via capacitor C2010. This causes the tube to conduct and capacitor C2007 to charge to approximately the peak voltage (E) via C2020 and V206, as shown by the solid line in the figure. Since C2020 and C2007 are in series, and each is charged to approximately E, their resultant sum is 2E.

(c) When the output of T2001 goes negative, V203 cuts off. This negative voltage via C2010 also cuts off V206. Notice that this negative voltage forward-biases tube V205, causing it to conduct. With V205 conducting, capacitor C2007 receives an additional charge of approximately E via V205, as shown by the short-dashed line in the figure. Notice that C2007 is now charged to 2E and C2020 is charged to E. The sum of these two charges is of course equal to 3E, and is approximately equal to the output voltage. Because of the high frequency involved capacitor C2007 and C2020 do not discharge appreciably between alternate half cycles.

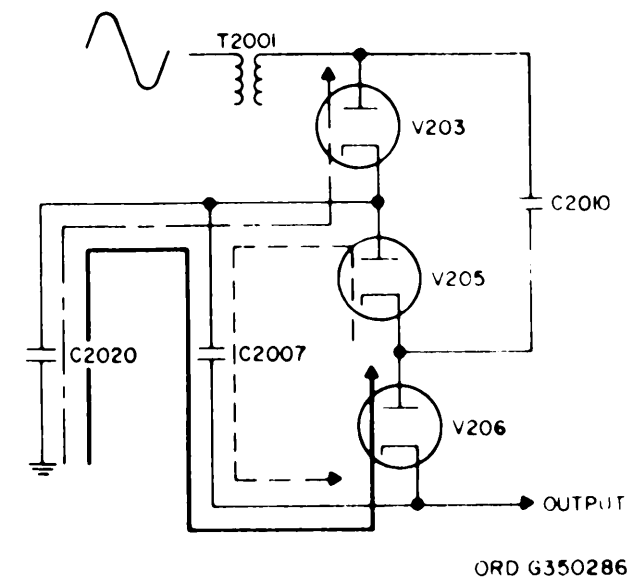

Figure 3-1.1. Voltage tripler.

(2) *Negative 1350 volt supply.* An ac voltage from the secondary tap of T2-01 is applied to half-wave rectifier CR2001 (zone D2), which passes only the negative half cycles. This is then filtered to become the -1350-vdc supply.

c. *High-Voltage Regulation.* The -135p volts is applied through a resistor network to, HV ADJ variable resistor R2009R. By adjusting R2009R, which has its ends connected to the 100-vdc regulated and 200-vdc regulated supplies, you can control the input bias at the control grid (pin 7) of V201A to -51 volts. This is the bias necessary for the stable operation of the high-voltage oscillator. If the -1350-volt potential varies, the bias to V201A is affected. This variation produces a change in the plate voltage of V201A which is coupled to the grid of V201B (pin 2). The output from V201 (pin 1) is applied to the screen grid (pin 9) of Hartley oscillator V202, causing its conduction to change. The variation in conduction of V202 causes the output frequency of the oscillator to change. The variation in frequency is related to output voltage. That is, as the tube conducts more heavily the frequency increases, and as the frequency increases the output (negative) voltage increases. Since this increased negative voltage is applied to the grid of V201A, it has the effect of reversing the process. Decreases in output voltage also tend to reverse the process, but in the opposite direction. Therefore, the voltage output must stabilize at some value which may be established by adjusting R2009R.

3-5.1. Low Voltage Power Supply (Newer 765 MH, 765MH/F and 765MA)(Figs. 3-1.2, 3-1.3, and 6-1.1)

a. *Power Transformer.* Low voltage and heater power for this instrument is provided by power transformer T1001. The primary is wound with two equal 115-volt windings that can be switched either in parallel for 115-volt operation, or in series for 230-volt operation via the 115V/230V selector switch S101. The secondaries contain four separate windings which provide power to the regulated supplies and two separate heater windings.

b. *Regulated Supplies.* Four regulated and two unregulated supplies are provided. All of the regulated supplies are of the constant output voltage series-passing type.

The basic reference for all of the regulated supplies is established by the fixed drop across zener diode CR1304. This constant drop or reference voltage is applied to the base of Q1302, which is one of the inputs to differential amplifier Q1301 and Q1302. The other input to the amplifier is connected across a divider consisting of R1302 through R1305 which samples a portion of the -50V regulated output.

A portion of this sample voltage is tapped by the -50V ADJ variable resistor R1303, and is applied to the base of Q1301. R1303 is adjusted so that the output is also the voltage reference source for the other low-voltage regulated supplies. Thus, voltage adjustments are always made in the sequence starting with the -50-volt supply and ending with the +200-volt supply.

Since the operation of the low-voltage regulated supplies is similar, only the +50-volt supply is described. CR1201 and CR1202 are connected in a conventional full-wave rectifier circuit. The rectified output is capacitively filtered by C1201, shunted by resistor R1202, and applied to the voltage regulator.

Operation of the regulator is as follows. Assume the output voltage tends to decrease. This will lower the base voltage of error detector dc amplifier Q1201, and raise the base voltage of emitter follower driver Q1202.

The increase in voltage at the emitter of Q1202 is applied to the base of series-passing transistor Q1203. The resultant increase in voltage at the emitter of the pass transistor is such as to return the output voltage to its proper value.

c. *Voltage Calibrator.* The power-line frequency voltage from T1001 is applied to the base of voltage calibrator Q1051 through limiting resistor R1051. Negative and positive voltage excursions will drive the transistor into and out of conduction at the line-frequency rate. The resulting square wave is applied to a voltage divider consisting of R1053 and R1054. The attenuated calibrator output of one volt peak-to-peak is coupled to the amplifier plug-in when the VOLTS/DIV switch is set to CAL. The plus 100-volt supply and the saturation voltage of the transistor will determine the peak-to-peak voltage excursion of the calibrator waveform.

3-5.2. CRT Circuits (Newer 765MH and 765MH/F)(Fig. 6-1.2)

a. *CRT Beam Control Circuits.* INTENSITY control R2016, part of the negative high-voltage divider, is used to vary the cathode-ray tube grid voltage to adjust the beam current. FOCUS control R2014 is provided to vary the voltage at the focusing anode to set the second cross-over point right at the screen of the cathode-ray tube. ASTIGmatism control R2022F is provided to vary the voltage at the astigmatism anodes to focus the spot in both axes simultaneously. The PATTERN CORREction service adjustment is set to vary the field the cathode-ray beam encounters as it emerges from the deflection system to control the linearity at the extremes of deflection. BEAM ROTATE front-panel screwdriver control R2022 is provided to vary the current through coil L2001 around the neck of the CRT. The current varies the field strength which the CRT beam intercepts, causing it to rotate. This compensates for the earth's magnetic effect on trace alignment.

b. *High-Voltage Power Supply.* Accelerating voltages for the cathode-ray tube are obtained by rectifying a 30-KHz high voltage produced by transistor oscillator Q2002. This transistor is connected as a class C oscillator, with the primary of transformer T2001 tuned by the strayed capacitance and the reflected secondary impedance. The output of the oscillator is stepped up by T2001 and applied via a conventional solid-state tripler network consisting of CR2050 through CR2052, to the post-deflection accelerator of the cathode-ray tube. The negative high-voltage supply is derived from a tap on the secondary winding of transformer T2001, which is connected to half-wave rectifier CR2001. The rectified output of -1440 volts is capacitively filtered by C2008, C2009, and C2011 and provides the necessary operating potentials for the proper intensity and focusing of the cathode-ray tube. Regulation of the high-voltage negative supply is accomplished by sampling a portion of the rectified output and applying a correction signal back through HV regulator Q2000 to Q2002 to the base of HV oscillator Q2003. This action changes the amplitude of oscillation of Q2003 and T2001 in such a manner as to restore the high-voltage output to its present level. Variable resistor R2009R, HV ADJ, is provided to preset the output of the high-voltage supply to its proper level.

c. *Normal Sweep Unblanking.* The cathode-ray tube used in this oscilloscope has two additional beam deflection plates, which cut off the electron beam independently of the control grid. In beam gate blanking, the electron beam is always turned on and passes through an aperture in the center of a blanking shield. Behind this shield is a set of deflection plates, one of which is connected to a fixed +50 volt source, while the second deflection plate is connected to the unblanking gate from the X plug-in. When the time base is sweeping, both beam gate deflection plates are at the same potential, and the electron beam passes through the aperture in the blanking shield. When the sweep ends and the unblanking gate voltage increases, the beam is deflected behind the blanking plate and the screen is dark. Beam control pulses (trace brightening and retrace blanking pulses) can easily be dc coupled since these beam deflection plates are electrically close to ground. Hence, the display is visible only during the forward sweep interval and is blanked during the retrace and lockout interval.

d. *Fast Single Sweep Unblanking.* A back-of-panel slide switch is provided on the high-voltage and high-frequency main frame models so that both NORMAL (beam gate blanking) and SINGLE SHOT (grid-cathode blanking) are available. Cathode drive for beam brightening is desirable when high writing rates are required to assure maximum beam current with minimum spot size. When it is desired to record high-speed, single-shot transients, the back-of-panel beam brightening switch is set to FAST SINGLE SWEEP ONLY. This technique completely turns off the electron beam, eliminating the possibility of film fogging and loss of information when the lens is open for an extended period.

3-5.3. CRT Circuits (765MA)(Fig. 6-1.3)

a. *CRT Beam Control Circuits.* FOCUS and ASTIGMATISM controls are provided for optimum spot shape and size adjustment. The Pattern control adjusts the shape of a full raster display for minimum distortion. The BEAM ROTATE front panel screwdriver adjust permits the trace to be perfectly aligned with the CRT internal graticule.

b. *High-Voltage Power Supply.* Q2005 is a power oscillator operating at a frequency of approximately 40 kHz and is controlled in amplitude by the error amplifier consisting of Q3001, Q3002 and Q3003. The error amplifier compares the rectified and filtered high voltage with the +100 volt power supply, through appropriate divider resistors, to obtain a regulated -1150 volt power supply. This voltage is set exactly using R3026, H.V. ADJ. Identical bifilar windings on T2001 provide independent grid and cathode supplies for the CRT to allow a DC coupled Z-Axis.

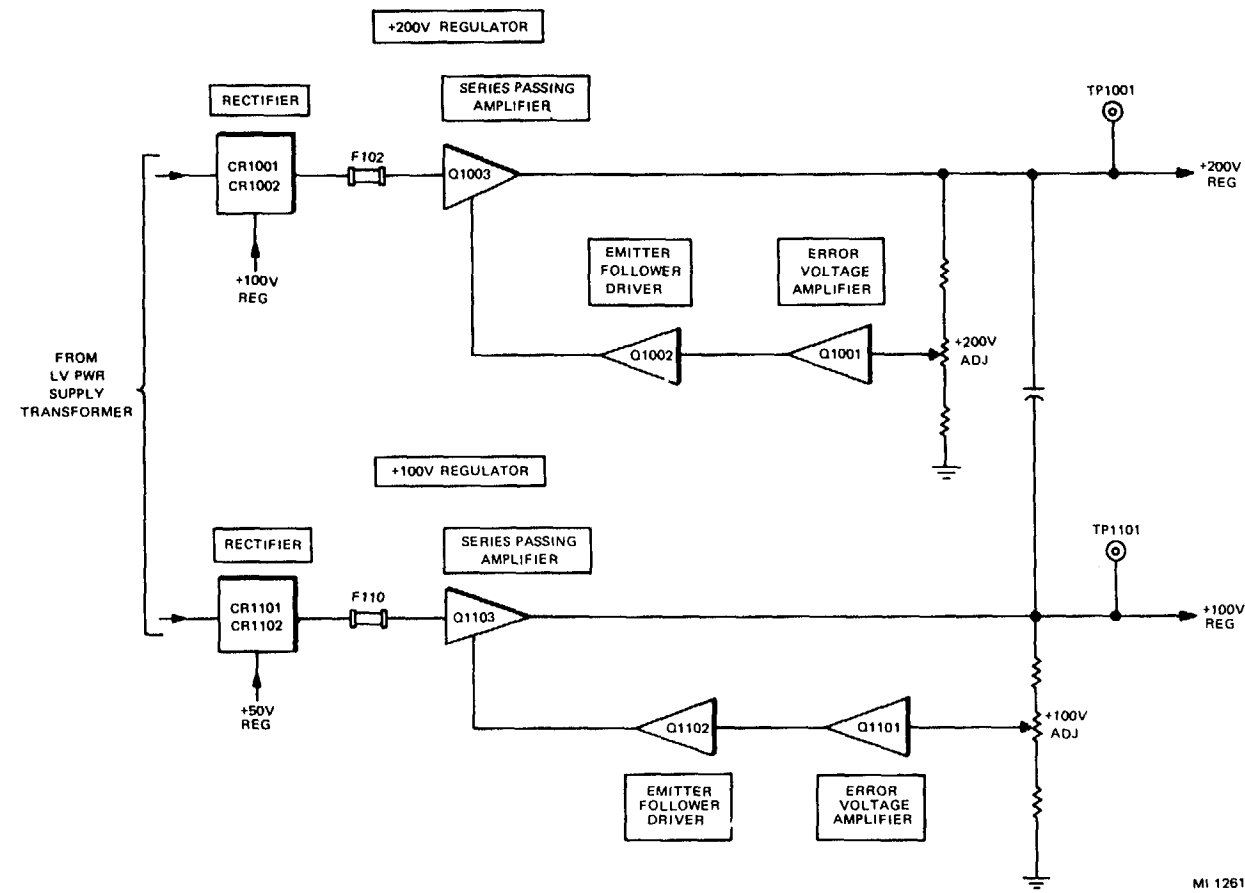

Figure 3-1.2. +200V and +100V regulators, functional block diagram, newer 765MH, 765MH/F and 765MA.

Q2004 is a pre-regulator supplying +23 volts DC to operate Q2005. A high voltage multiplier provides +10,800 volts for the CRT final accelerator.

c. *Z-Axis Amplifier.* The gate, strobe, chopped-blanking and EXT Z-AXIS signals are summed together with the front panel INTENSITY control (R2016) current at the emitter of Q4002, Q4003, Q4004 and Q4006 form a feed-back amplifier with wide dynamic range. The resulting output signal is applied to the low potential side of the high voltage supply for the CRT grid. Thus, the CRT grid potential may be varied with respect to the CRT cathode to control intensity.

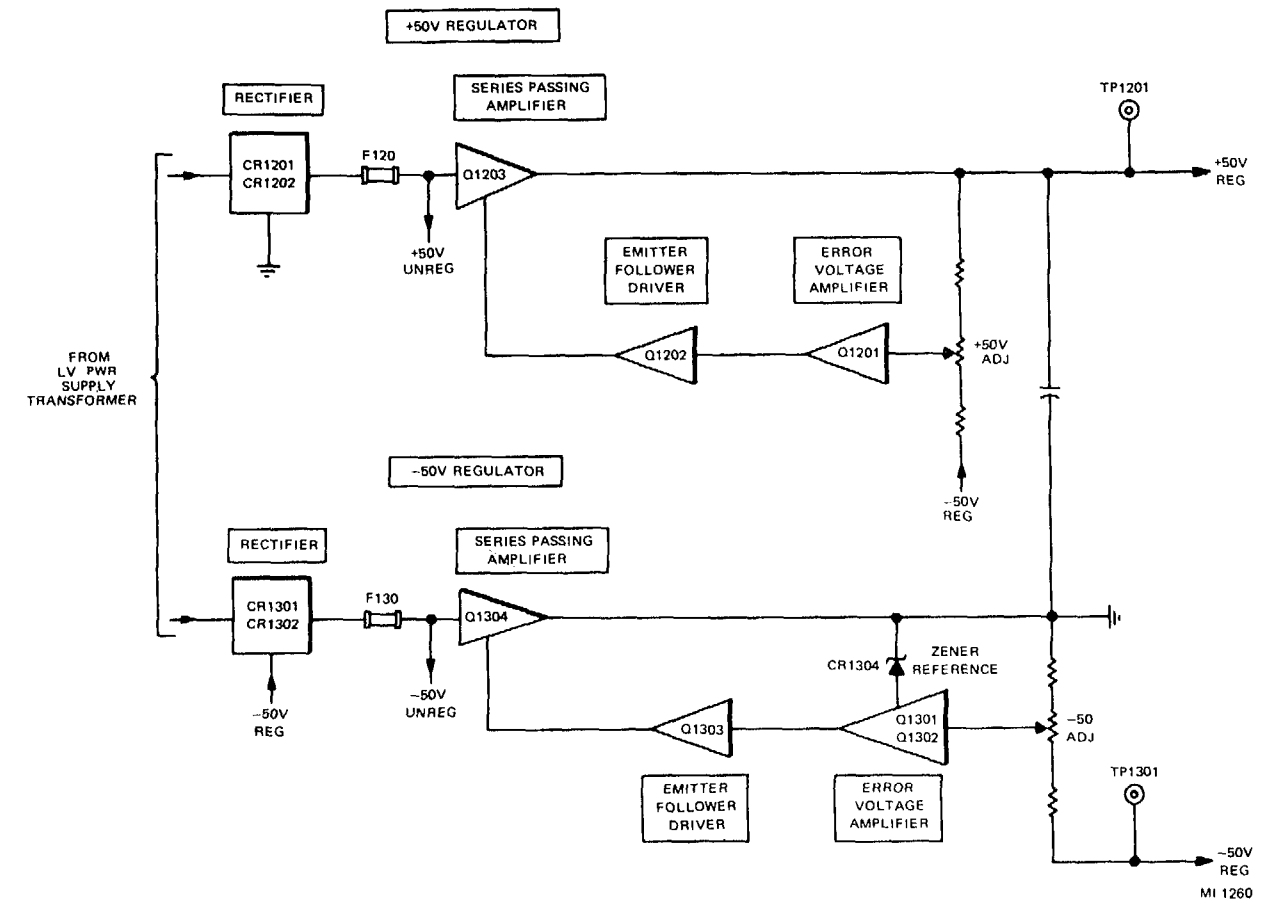

Figure 3-1.3. +50V and -50V regulators, functional block diagram, newer 765MH, 765MH/F and 765MA.

Section III. FUNCTIONAL THEORY - DUAL TRACE

PLUG-IN TYPE 76-02A (Y-DEFLECTION)

3-6. Signal Coupling and Voltage Attenuation (Fig. 4-4)

The dual trace plug-in consists of two identical channels (channel A and channel B). In this section we will describe only channel A.

a. Signal Coupling.

(1) Each channel has a one-megohm input resistance shunted by an input capacitance. At high frequencies this results in a low input impedance. However, the input impedance can be raised and the loading effect lessened by using the (nine-megohm) 10:1 probe (zone A1). The probe has an adjustable compensating capacitor which shunts the probe, to keep the input impedance constant as a function of frequency.

(2) Using one of five positions on NORM-INVERT switch S911, you can select the polarity and type of coupling through which the input signal passes. With the NORM-INVERT switch set to the NORM section of the switch, the displayed waveform will have the same polarity as the input signal. Setting the NORM-INVERT switch to the INVERT section of the switch reverses the polarity of the displayed waveform.

(3) The AC position of the NORM-INVERT switch is used for input signals greater than 10 cps. With the NORM-INVERT switch at AC, capacitor C9115 (zone A2) is inserted in the input circuit so that it blocks the dc component of the input signal.

(4) The DC position of the NORM-IN-VERT switch is normally used for dc signals, although it may also be used for ac signals up to 25 MHz. With the switch set at DC, the input signal retains its dc component, and is coupled directly to the vertical amplifier. The GND position of the switch makes dc balancing of the input amplifier much easier.

b. Input Voltage Attenuation.

(1) After passing through the NORM-INVERT switch, the input signal goes to the input voltage attenuation circuitry (zone B3-B5). By using VOLTS/DIV switch S910 (zone A4), you can select, either individually or in various combinations, four input attenuator networks. These operate in conjunction with the interstage attenuator (zones C4, C5) which are covered in paragraph 3-7c. The combined input and interstage attenuators provide ten calibrated input ranges of .01, .02, .05, 0.1, 0.2, 0.5, 1, 2, 5, and 10 volts per division. Without attenuation, that is, with the VOLTS/DIV switch set to X1, the sensitivity of the vertical amplifier is 0.005 volts per division. Table 3-1 shows the individual input ranges, and the input and interstage attenuator network combinations that provide the various attenuation ratios.

Table 3-1. Voltage Attenuation Factor

Input range VOLTS/DIV	Input attenuators	Interstage attenuators	Attenuation ratio
Not CAL	X5	applicable	5:1
10	X2, X100	X10	2000:1
5	X100	X10	1000:1
2	X4, X10	X10	400:1
1	X2, X10	X10	200:1
0.5	X10	X10	100:1
0.2	X4	X10	40:1
0.1	X2	X10	20:1
0.05	X1	X10	10:1
0.02	X1	X4	4:1
0.01	X1	X2	2:1
0.005	X1	X1	1:1

(2) Let's discuss examples of how the various networks combine in the input voltage attenuator to produce a particular calibrated input range. For instance, setting the VOLTS/DIV switch to .05 volts per division, the input signal goes directly to the preamplifier circuit. It is then attenuated by the 10:1 interstage attenuator net-work.

(3) In another case the VOLTS/DIV switch is set to 2 volts per division. With the switch in this position, the input signal passes through the 4:1 attenuator and the 10:1 attenuator. These two attenuators reduce the input signal by a ratio of 40 to 1. The input signal then goes to the preamplifier and the interstage attenuator, where the signal is attenuated by an additional factor of 10:1 resulting in an overall attenuation of 400 to 1.

(4) The VOLTS/DIV switch also provides a CAL position, where a 5:1 attenuator is inserted to automatically switch out the input signal and replace it with an internally generated calibrated signal (square wave). The peak to peak value of the calibrated signal produces four divisions of vertical deflection on the CRT screen.

3-7. Preamplifier

a. Paraphase Amplifier. After passing through the input voltage attenuation network, the input signal goes to paraphase amplifier V920, V921 (zones C1, D1) via high-frequency compensating network R9201, R9206, C9201, C9202 (zone C1.) This amplifier stage converts the single-ended input signal into a push-pull output. DC BAL (fine) variable resistor R9202, and DC BAL (coarse) variable resistor R9200 control the operating level of the paraphase amplifier. VARIABLE resistor R9213, in the common cathode circuit, regulates the gain of the stage. The DC BAL resistors are properly set, when without a signal you can vary R9213 throughout its entire range without causing a repositioning of the trace on the CRT. Diode clamp CR9200 protects the amplifier tubes when power is initially applied to the circuit.

b. Preamplification. The push-pull output of the paraphase amplifier goes to the amplifier-emitter follower combinations Q9200, Q9202, and Q9201, Q9203. These stages are dc coupled, providing a good low-frequency response, and assuring frequency stability and a low signal-to-noise ratio. In the control circuit of the preamplifier there are three adjustments. Front-panel GAIN ADJ variable resistor R9212 sets the on-screen amplitude of the signal to the appropriate relative scale of the graticule. ATTEN BAL variable resistor R9234R balances the bias on Q9202 and Q9203, assuring that each stage is referenced to the same voltage level (this also prevents the no-signal trace from repositioning when the load changes). Capacitor C9209 adjusts the bandwidth of the stage to permit a sharp rise time.

c. Interstage Voltage Attenuation.

(1) After passing through the preamplifier circuit and NORM-INVERT switch S920, the input signal goes to the interstage voltage attenuator. This attenuator reduces the preamplifier output before it goes to the delay line drivers (par. 3-9).

(2) Figure 3-2A shows the 10:1 interstage resistance attenuation network formed when we set the VOLTS/DIV switch to any position between 0.05 and 10. Using the computations shown, you can see that the ratio between total network resistance and output resistance is approximately 10 to 1. Figure 3-2B through D shows the resistance attenuation networks formed when the VOLTS/DIV switch is set to any other position between 0.005 and 0.02.

3-8. Channel Switching

a. Channel A.

(1) Amplifiers Q9204 and Q9205 (zones A8, B8), which comprise the output stages of the channel A amplifiers, receive the pushpull input signal from the interstage voltage attenuator. POSITION control R9234 (zone B8), in the common emitter circuit of the amplifiers, regulates the dc level of the amplifiers which, in turn, determines the vertical position of the trace that is displayed on the CRT. Also in the emitter circuit is a compensating network which improves the high frequency response of the amplifiers. These amplifiers are switched on or off by the channel switching circuit, depending on the position of the MODE switch (zones B7-D7).

(2) Electronic switch Q9600, Q9601 (zone B8), a bistable multivibrator controls the operation of the channel A and channel B amplifiers. The electronic switching circuit can allow either one or both of them to operate normally. When the MODE switch is set to A, a constant negative voltage is applied to the base of Q9601, cutting it off. With Q9601 cut off, a positive voltage forward biases diode CR9301 (zone A7), which disables the channel B amplifiers. At the same time, the negative-going output of Q9600 (now conducting) reverse-biases diode CR9201 (zone A8), which allows channel A amplifiers Q9204 and Q9205 to operate normally.

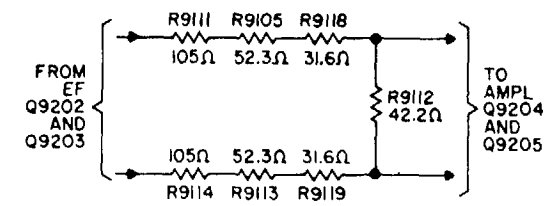

.05 TO 10 VOLTS PER DIVISION SENSITIVITY

$$R_T = R9111 + R9105 + R9118 + R9112 + R9119 + R9113 + R9114 = 420 \text{ OHMS}$$

$$R_{OUT} = R9112 = 42.2 \text{ OHMS}$$

$$\frac{R_T}{R_{OUT}} = \frac{420}{42.2} \approx 10$$

ATTENUATION=10:1

(A)

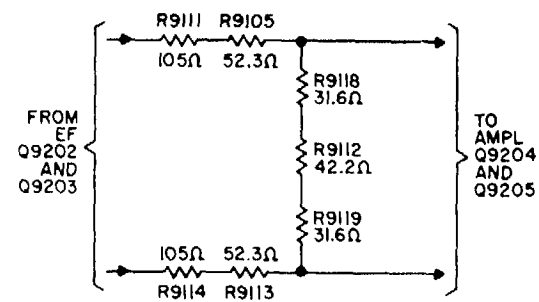

.02 VOLTS PER DIVISION SENSITIVITY

$$R_T = 420 \text{ OHMS}$$

$$R_{OUT} = R9118 + R9112 + R9119 = 105.4 \text{ OHMS}$$

$$\frac{R_T}{R_{OUT}} = \frac{420}{105.4} \approx 4$$

ATTENUATION=4:1

(B)

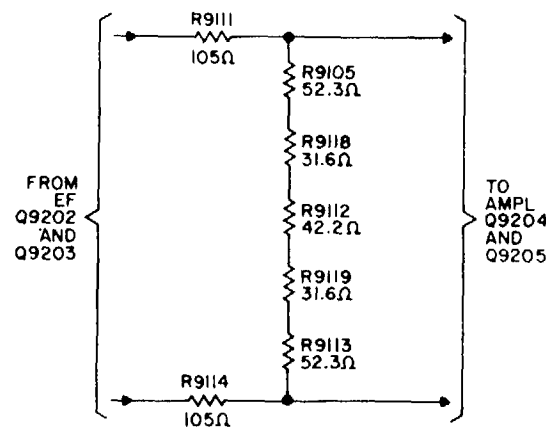

.01 VOLTS PER DIVISION SENSITIVITY

$$R_T = 420 \text{ OHMS}$$

$$R_{OUT} = R9105 + R9118 + R9112 + R9119 + R9113 = 210 \text{ OHMS}$$

$$\frac{R_T}{R_{OUT}} = \frac{420}{210} \approx 2$$

ATTENUATION=2:1

(C)

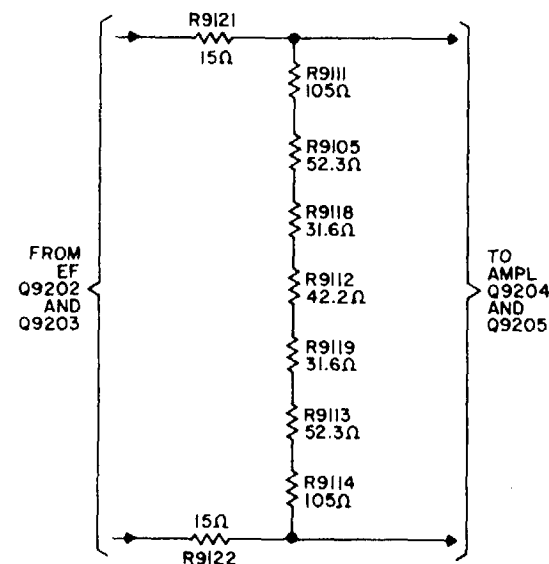

.005 VOLTS PER DIVISION SENSITIVITY

$$R_T = 450 \text{ OHMS}$$

$$R_{OUT} = 420 \text{ OHMS}$$

$$\frac{R_T}{R_{OUT}} = \frac{450}{420} \approx 1$$

ATTENUATION=1:1

(D)

ORD G350287

Figure 3-2. Interstage voltage attenuator equivalent circuit.

b. Channel B.

(1) Setting the MODE switch to B reverses the conditions described in a above. Now a constant negative voltage is applied to the base of Q9600, cutting the transistor off. With Q9600 cut off, a positive voltage forward-biases diode CR9201, which disables the channel A amplifiers. Diode CR9301 is now reverse-biased by the negative-going output of Q9601 (conducting), and the channel B amplifiers operate normally.

(2) When the channel A amplifiers are disabled, diodes CR9202 and CR9203 in the collector circuits of Q9204 and Q9205 become reverse-biased by a positive voltage that is applied to their cathodes via resistors R9258 and R9259 (zones A9, B9). Reverse-biasing these diodes effectively opens the collector circuit of both transistors (Q9204 and Q9205). This isolates the active channel B amplifiers from the inactive channel A amplifiers, preventing capacitive loading, and ensuring that the maximum available bandwidth is maintained.

(3) If the MODE switch is set to A, the channel A amplifiers are active, and the conditions described in (2) above are reversed. Now diodes CR9302 and CR9303 are reverse-biased, opening the collector circuits of the channel B amplifiers.

c. Alternate Switching.

(1) Setting the MODE switch to ALT, alternately activates and deactivates the channel A and channel B amplifiers. With the switch at ALT, there is no constant negative voltage applied to the base either Q9600 or Q9601 of the electronic switch. The operating state of the electronic switch is now controlled by a negative pulse.

(2) Blanking multivibrator Q9701, Q9702 (zone D9) generates the negative pulse which is then applied to the electronic switch via diode CR9601 (zone B8). Let's take a closer look at the blanking multivibrator. With the MODE switch at ALT, the blanking multivibrator functions as a monostable multivibrator. Transistor Q9702 is normally cut off, and diodes CR9704 and CR9708 (zone C8) are normally reverse-biased. Diode CR9704 is reverse-biased by a negative voltage applied to its anode from a voltage divider in the delaying sweep plug-in. Diode CR9708 is reverse-biased by a negative voltage applied to its anode via the MODE switch and R9705. The blanking multivibrator remains in this state until a positive trigger pulse from the delaying sweep plug-in (representing the end of the sweep) overcomes the bias on diode CR9704. The positive trigger is applied to the base of Q9702, driving it into the ON state. Diode CR9708 is sufficiently reverse-biased to prevent the positive trigger from being applied to the collector of Q9701. After the trigger pulse has been applied, the multivibrator reverts to its initial operating state. Diodes CR9701 and CR9707 (zone D9) prevent the collectors Q9701 and Q9702 from going too positive.

(3) Since the positive trigger has a very small time duration and the time constant of the blanking multivibrator, acting as a monostable multivibrator, is very small, a negative pulse of very short duration is generated. This negative trigger is applied to the electronic switch via diode CR9601 (zone B8) and steering diodes CR9602 and CR9603, alternately changing the operating state of the circuit. The operating state of the electronic switch, therefore, determines whether the channel A or channel B amplifiers are activated.

(4) During the transition interval when one pair of amplifiers is activated and the other pair is activated and the other pair is deactivated, a display should not appear on the CRT. To prevent a display, the same negative pulse output of the blanking multivibrator is applied to amplifier Q9703 (zone D10). This negative pulse is inverted by Q9703 and the resulting positive-going signal is applied to the cathode of the CRT. This positive signal reduces the cathode current and results in the blanking of the CRT. Clamp circuit Q9704 and diode CR9702 prevent the collector of Q9703 from going too negative.

d. Chopped. Setting the MODE switch to CHOP, removes the negative voltage that reverse-biases diode CR9708 (zone C8). The negative voltage is now applied to diode CR9704, which is reverse-biased so that the trigger pulse is prevented

from going to the blanking multivibrator. This causes the blanking multivibrator to function as a free-running instead of a monostable multivibrator. As such, the blanking multivibrator generates negative pulses at a rate of 60 kc. This means that the electronic switch circuit is triggered at this rate, and that the channel A and B amplifiers are being alternately activated (approximately 6 microseconds on the approximately 9 microseconds off).

e. *Channel A + Channel B.* Setting the MODE switch to A + B deactivates electronic switch Q9600, Q9601 by removing the B+ voltage. This activates the channel A and channel B amplifiers simultaneously so that the resultant output (channel A + channel B). You will notice that diodes CR9202 (zone A9) and CR9203 (zone B9) are no longer reverse-biased, and therefore, the loading of one channel by the other reduces the overall bandwidth of the system.

3-9. Delay Line Drivers

The output of both the channel A and channel B amplifiers is applied to delay line drivers Q9400, Q9401, Q9402, and Q9403 (Darlington emitter followers). After passing through the delay line drivers, the signal is applied to a balanced, distributed-bifilar-helical, delay line. When the oscilloscope is set up for internal triggering, the delay line provides the necessary time delay (230 nanoseconds) so that the leading edge of the signal, which triggers the delaying sweep plug-in, can be viewed with the base line. Networks Z9401, R9413, and Z9402, R9414 provide the proper termination for the delay line, and also compensate for the input capacitance of emitter followers Q9413 and Q9414. By adjusting DELAY LINE TERM ADJUST resistor R3 (zone A10), we can be sure of obtaining a proper termination.

3-10. Trigger Pick-off Circuit

a. Notice that a portion of the output from the delay line drivers goes to trigger pick-off amplifiers Q9501 and Q9502 (zone C10). These amplifiers convert the double-ended output of the delay line drives (push-pull signal) into a single-ended signal. After it is amplified and inverted by the trigger pick-off amplifiers, the signal goes through emitter follower Q9503 to the SOURCE switch in the delaying sweep plug-in. Amplifier Q9505 and TRIG DC LEVEL variable resistor R9503 provide the proper dc operating level for emitter follower Q9503.

b. A portion of the output from the emitter follower Q9503 is also applied to amplifier Q9504. If at the same time POSITION control R9234 (zone B8) is set so that the displayed signal appears on the CRT, Q9504 functions as a normal class A amplifier. In this instance, the amplifier doesn't produce sufficient output voltage across either of the beam position indicators (neon lamps DS9501 and DS9502) to cause them to illuminate.

c. Let's see what happens when the POSITION control is set so that the signal is not displayed on the CRT (where the electron beam is directed below the bottom of the CRT screen). Under these conditions, amplifier Q9504 is cut off and the voltage difference across lamp DS9502 exceeds its firing potential, causing them to illuminate.

d. However, if the POSITION control is set where the electron beam is directed above the top of the CRT screen, amplifier Q9504 is driven into saturation. This makes the voltage difference across lamp DS9501 high enough to cause it to illuminate. At the same time, lamp DS9502 is extinguished because there is practically no voltage difference across it.

3-11. Vertical Deflector Amplifier

a. Passing through emitter followers Q9413 and Q9414, the double-ended output signal of the delay line is applied to amplifiers Q9404 and Q9405. In the common emitter circuit of both amplifiers, a compensating network improves the frequency response of both stages. The amplified and inverted signal passes through two more emitter followers, Q9406 and Q9407, to another pair of amplifiers, Q9408 and Q9409. These amplifiers amplify and invert the signal and pass it on to the

vertical deflection plates in the CRT. This last pair of amplifiers also uses a compensating network (part of the common emitter circuit) to improve the frequency response.

b. Notice that a portion of the output signal from amplifiers Q9408 and Q9409 is fed back to a network consisting of R9255, R9254, R9256, R9261, and C9218. After passing through this network, the signal is applied to Q9400 and Q9401 of the Darlington emitter followers. Feeding back a portion of the output serves to improve the frequency response of the circuit.

Section III.1. FUNCTIONAL THEORY - DUAL TRACE PLUG-IN

79-02A AND CRT TERMINATION NETWORK (MAIN FRAME)

3-11.1. Preamplifiers (fig. 4-4.2)

Two almost identical preamplifiers (CH1 and CH2) are provided. Since these units are nearly identical, only one unit is discussed and the other is compared.

a. *Input Coupling.* Input connector J1 for channel 1(A1) offers an input impedance of 1 megohm and 14 picofarads to the applied signal. The signal applied to J1 may be directly coupled through R1, capacitively coupled through C1, or the input to the instrument may be grounded, as established by the DC-AC-GND switch. The selected signal is first applied to a capacitive-resistive network which comprises a frequency-compensated voltage divider. The particular attenuator used is selected by VOLT/DIV switch S902. In the 20 position of this switch, the Y plate of C2 is connected through S902-4, while R8, R9, C11, and C19 are connected through S902-3 (input) and S902-2 (output). In the 20 position of this switch, the Y plate of C2 is connected through S902-4, while R8, R9, C11, and C19 are connected through S902-3 (input) and S902-2 (output). R8 and R9 comprise a low frequency divider, C11 and C19 compromise a high frequency divider, and C2 acts as a trimmer. C11 may be tuned for the desired frequency response. That portion of the signal which appears across R9 in parallel with C19 is coupled through S902-2 to the amplifier circuits. All the remaining switch positions introduce a similar divider. The 10 volts through the 0.1 volt dividers, also have frequency adjustments (C12, C13, C14, C16, C17, and C18, respectively).

b. *Differential Amplifier.* The input circuit for the amplifier section is differential V921 and V922 (B7). The VARIABLE control on the front panel of the dual trace plug-in 79-02A adjusts the B+ on both sections of the differential amplifier. This control may be set to the detent (CAL) position, or to a position of less voltage. When the control is set to other than the CAL position, it closes a switch which completes the circuit to illuminate the UNCAL indicator. DC BAL (coarse and fine) controls are available to balance conduction of the differential amplifier, thus preventing deposition of the trace as the VARIABLE controls is operated. Gas compensation adjustment R201 is provided to neutralize the effect of any leakage currents in the differential amplifier. GAIN ADJ control R227, which sets the gain of the amplifier to a calibrated level, and invert balance control R231, which minimizes shifting of the trace when the position of the NORM-INVERT switch is changed, are provided.

c. *Amplifiers.* A series of amplifiers consisting of common-base amplifier Q201, common emitter amplifier Q204, and emitter follower Q206 are complemented by Q202, Q203, and Q205, with the same configuration. These two series of amplifiers, in conjunction with NORM-INVERT switch, compromise a push-pull amplifier circuit. The NORM-INVERT switch (A9) makes it possible to cross-connect the amplifiers. With the switch in the NORM position, the signal from Q201 is applied to Q203. The same relationship exists between exists between Q202 and Q203 or Q204. Thus, when the INVERT position of the switch is selected, the transistor line-up is reversed. The POSITION control (A10) varies the bias on Q203 and Q204 to deflect the trace vertically.

d. *X10 Amplifier Section and Output Amplifier.* The VARIABLE switch may be pulled out to increase the gain of the preamplifier by a factor of 10. In the normal (depressed) position of the switch, B+ is removed from the output stage of the

X10 amplifier, and the stages are bypassed. In the PULL X10 position of the switch, emitter follower Q207 with common emitter amplifiers Q209 and Q211 (B12) comprise one series of amplifiers. Q208, Q210, and Q212 comprise a second series which completes the push-pull amplifier. The outputs from the X10 amplifier or the bypass signal, as selected, are coupled to the switching amplifier through emitter followers Q801 and Q802.

e. Channel 2 Channel 2 has an almost identical arrangement to channel 1. The CH2 input signal, attenuated by attenuators which are selected by VOLTS/DIV switch S912 (D2) is push-pull amplified by two series of amplifiers (D7). With the NORMAL-INVERT switch set to NORMAL and the PULL X10 switch closed, one series of amplifiers consists of V941, Q401, Q404, and Q406, Q408, Q410, Q412, and Q902. The other series consists of V942, Q402, Q403, Q405, Q407, Q409, Q411, and Q901. The NORMAL-INVERT and PULL X10 switches operate in the same manner as noted in *c* and *d* above. DC BAL, VARIABLE, GAIN ADJ, and INVERT BAL controls are provided in the same circuit arrangement as was previously discussed. A channel 2 output signal (D11), and a signal used for channel 2 trigger separation, are taken from the output of the channel 2 preamplifier.

3-11.2. Mode Selection

a. General. The mode selection circuits consist of emitter follower Q703 (a trigger coupling stage), oscillator Q704, switching multivibrator Q701 and Q702, switching amplifiers Q803, Q804, Q903, and Q904, MODE selection switch S709 and the blanking pulse amplifier and trigger circuits. There are five possible modes (CH1, CH2, ALT, CHOP, and ADDED). These modes are discussed in *b* through *f* below.

b. CH1 and CH2 Modes. In the CH1 mode, trigger oscillator Q704 (A14) is biased below cut-off by -50v applied through S709-1F, while the input trigger to trigger amplifier Q703 is blocked by bias, due to the removal of +50v from the input network (see switch S970-1R). Forward bias is applied to Q701 through S709-1R (A16) and its conducts. With Q701 conducting Q702 is cut-off (bistable multivibrator action). In this condition, diode CR801 is cut-off and switching amplifiers Q803 and Q804 (C11) are allowed to conduct, while a positive voltage at the collector of Q702 is applied through CR901 to switching amplifiers Q903 and Q904. The positive voltage (reverse bias) cuts off Q903 and Q904. Thus only the channel 1 signal is amplified. In the CH2 mode, forward bias is removed from Q701 and applied to Q702 (A16). Therefore, Q702, and, in turn, Q903 and Q904 conduct, while Q803 and Q804 are cut off. In this state, only the channel 2 output is amplified.

c. ALT Mode. In the ALT mode, the reverse bias on the input network for emitter follower Q703 (A13) is removed (see S970-1R), and the blanking trigger, applied through emitter follower Q703, reduces the bias on oscillator Q704. The oscillator operates, and the resultant trigger, coupled through T201, causes switching multivibrator Q701 and Q702 to pass through a half cycle. A second trigger completes a cycle for the switching multivibrator, and therefore the switching multivibrator, and therefore the switching multivibrator and switching amplifiers change between channel 1 and channel 2 on alternate sweeps.

d. Chop Mode. In the chop mode, the reverse bias for oscillator Q704 (A13) is removed (S709-1F) and the stage acts as an oscillator. The switching rate is set at 100 kc or 1 mc by chop rate switch S971. For each cycle of oscillation from the oscillator, a trigger is coupled to the switching multivibrator, and the switching multivibrator controls the switching amplifiers as noted in *b* above.

e. ADDED Mode. In the ADDED mode, B+ is removed from the switching multivibrator (S709-1F-A15). With B+ removed for the multivibrator, both sets of switching amplifiers (Q803, Q804, Q903, and Q904-A11 through D11) conduct, and the output signal is the algebraic sum of the two input signals.

f. Blanking Pulse Amplifier. To eliminate the transient which occurs when the vertical amplifier is switched from channel to channel, the CRT is blanked during trigger time. The blanking pulse developed by emitter follower Q706 (B17) is coupled

directly to the cathode of the CRT.

3-11.3. Common Amplifier Section and CRT Termination Network

a. General. At the output of the switching amplifiers, the signal from channel 2 joins the signal from channel 1 for amplification by one channel 1 for amplification by one channel of push-pull amplification by one channel of push-pull amplification. This push-pull arrangement is continued through the CRT termination network, in the main frame, to the CRT. The circuits include a delay circuit, a series of normal amplifiers, a differential amplifier, and the CRT termination network, as discussed in *b* through *e* below.

b. Delay Circuit. The selected signal (CH1, CH2, or both) is amplified by delay line drivers Q501 and Q502 (common emitter amplifiers) and applied to delay line DL501. Delay line DL501 introduces a 185 nanosecond delay in the signal. This delay is provided so that the horizontal sweep may start before the applied signal, thus allowing the leading edge of signals to be displayed. The signal is then applied through impedance Z501 to the following amplifier section; Z501 acts as an impedance matching device to match the delay line to the following amplifier circuits. Since the delay line can introduce minor transients into the signal line, capacitor C501 and resistor R511 (both adjustable) are provided to minimize the effect of these transients. R511 is normally adjusted to eliminate a dc shift, while C501 is adjusted to reduce any bumps which occur at the end of the initial delay line operation.

c. Amplifiers. A series of dc amplifiers consisting of common emitter amplifiers Q503 and Q505, with emitter follower Q507, are balanced by Q504, Q506, and Q508. These two series of amplifiers comprise a push-pull amplifier group.

d. Differential Amplifier. A two stage differential amplifier is provided. The input stage consists of Q512 and Q513 with current regulator (constant current) transistor Q510. Output level adjust R545, and BEAM FINDER S950, set the normal current for the input stage to the differential amplifier, and reduce this current to a very low level, respectively. If the BEAM FINDER switch is depressed when the CRT trace is off the screen, the trace will move to the edge of the screen. The second stage (common base type) consists of Q511 and Q514 with Q509 acting as a voltage regulator to retain a constant base voltage for each amplifier. This differential amplifier reacts very strongly to signals of opposite polarity, while tending to null out signals of the same polarity.

e. CRT Termination Network. The CRT termination network acts as an impedance match between the CRT plates and the differential amplifier. Low frequency peaking adjustment R65 and high frequency peaking adjustment C53 are provided. These controls are normally set to obtain the best possible reproduction of a square wave on the CRT.

3-11.4. Internal Trigger Generation

a. General. The vertical amplifier provides facilities for developing a trigger. This trigger may be selected as the oscilloscope triggering source by setting the SOURCE switch on the delayed sweep plug-in unit to INT. When INT is selected, the composite signal (NORM) or the channel 2 (CH2 ONLY) signal may be selected by the TRIGGER switch, as indicated by *b* below.

b. Trigger selection and level adjustment. In the NORM position of the TRIGGER switch, the output from Q604 (D13) is grounded by S960-2R, and only the output from Q610 appears at the base of Q606. In the CH2 ONLY position of the trigger switch, the output from Q610 is grounded and only the signal from Q604 appears in the output. Since the input to Q610 is grounded and only the signal from Q604 appears in the output. Since the input to Q610 is the composite signal from Q502, while the input to Q604 appears in the output. Since the input to Q610 is the composite signal from Q502, while the input to Q604 is the channel 2 signal from Q901, the composite signal or the channel 2 signal is selected. Each channel has a level adjustment (R618 or R619) which effects the dc voltage regulator Q606 by controlling voltage regulator Q605. The adjustments are set for a zero level dc output with no triggers applied.

c. *Amplifiers.* Common emitter stages Q606 and Q608, with emitter follower Q609, provide power and voltage amplification for the selected trigger. Regulator Q607 controls the voltage on the emitter of Q608 and the collector of Q609. The output trigger (INT) appears at J9001-25, and is coupled through the main frame to the delayed sweep plug-in unit.

3-11.5. CH2 OUT Circuit

A sample of the channel 2 signal is available at the CH2 OUT connector, on the front panel. The channel 2 signal, taken from Q902 (D10) and applied through emitter follower Q603 (A17) is amplified by common emitter stage Q602. This signal, adjustable in level by R614 (CH2 output level adj) is available at the CH2 OUT connector. R614 establishes the conduction level of gain control stage Q601, and Q601, in turn, regulates the bias on Q602.

Section IV. FUNCTIONAL THEORY-DELAYING SWEEP

PLUG-IN TYPE 74-13A (X-DEFLECTION)

3-12. Triggering (Fig. 4-5)

Note. The normal sweep channel and the delayed sweep channel use similar triggering circuits, therefore, only the functions of the switches and controls for trigger generation in the normal sweep channel are described.

a. *Sources of Trigger Input.* Using SOURCE switches S820 (zone A2), you can select any one of the three input signal sources from which a trigger is to be produced.

(1) *INT position.* In this position, the input signal, coming from the dual trace plug-in, passes through the SOURCE switch to COUPLING switch S821.

(2) *EXT position.* With the SOURCE switch at EXT, the input signal (from an external source connected to the EXT TRIG connector) passes through the SOURCE switch to the COUPLING switch via PULL EXT 10 switch S823.

(3) *LINE position.* In this position, the input signal taken from the 6.3 vac heater circuit in the low-voltage power supply, passes through the SOURCE switch to the COUPLING switch.

b. *Methods of Coupling Trigger Input.* By setting COUPLING switch S821 to only one of three positions, you select the type of circuit through which the input signal is to be coupled to the trigger circuit.

(1) *AC position.* In this position, the input signal passes through high-pass filter C8205, C8203, R8207; NORM-AUTO switch S824; and RC network R8206, C8202 to SLOPE switch S820. The high-pass filter rejects signals below 80 cycles.

(2) *ACF position.* With the COUPLING switch set to this position, the input signal is applied to the high-pass filter, now consisting of C8203, and R8207 and R8204 in parallel. With this new circuit configuration, the high-pass filter rejects signals below a frequency of 10 kc. After passing through the filter, the input signal continues through the NORM-AUTO switch to the SLOPE switch via R8206 and C8202. Since C8202 shunts R8206, the high frequency components of the signal will pass through undisturbed.

c. *Polarity Selection of Input Signal.* By setting SLOPE switch S822 to either one of two positions, you select the polarity of the input signal which is used to start the sweep.

(1) *"+" position.* In this position, the input signal after passing through the RC network (R8206, C8202) continues through the SLOPE switch to the grid (pin 4) of V8201 (zone B6), which constitutes half of a difference amplifier. The other half of the difference amplifier V8202 receives a dc bias volt-age at its grid (pin 4), through LEVEL control R8222.

(2) *"-" position.* In this position, the input signal after passing through the RC network, continues through the SLOPE switch to the grid of V8202. The dc bias voltage determined by the LEVEL control is now of course applied to the grid of V8201.

3-6.2

d. *Normal Trigger Generation.*

(1) *Input.*

(a) Before going into a description of how the trigger pulse is generated, assume that the switches described above are in the following positions:

SOURCE switch S820	INT
COUPLING switch S821	AC
SLOPE switch S822	+
NORM-AUTO switch S824	NORM

(b) Further assume that the input signal (output of the dual trace plug-in) is a sine wave. After passing through the switches, the high-pass filter, and the RC network, the sine-wave input signal is applied to amplifier V8201.

(c) The input to the other half of the difference amplifier, V8202, is a dc Voltage determined by the setting of the LEVEL, control. When the point on the positive-going slope of the sine wave is equal to the dc voltage, the difference amplifier is balanced and it produces a constant out put. When the positive-going slope of the sine-wave signal exceeds the dc voltage, the difference amplifier becomes unbalanced. In this state, V8201 conducts, producing a negative-going output which goes to the cathode of tunnel diode CR-8201, forward biasing it. When the positive-going slope of the sine-wave input is below the dc voltage, the difference amplifier is also unbalanced. In this state, V8202 conducts more than V8201, so that a more positive voltage is applied to the cathode of the tunnel diode, reverse-biasing it. When the difference amplifiers are unbalanced they cause the tunnel diode to produce a trigger pulse.

(2) Tunnel Diode.

(a) The tunnel diode is a voltage-stable semiconductor device that exhibits a negative resistance over a section of its forward-bias characteristic. Figure 3-3A shows a typical tunnel-diode characteristic curve. As shown on the curve, the tunnel diode is highly conductive and presents an extremely low impedance when it is reverse-biased. The reason the tunnel diode is highly conductive when it is reverse-biased is because the valence electrons of the semiconductor atoms *tunnel* across the PN junction from the P-type region to the N-type region. In the same way, when a small forward bias is applied to the diode, the electrons in the N-type region *tunnel* across the junction to the P-type region and the current increases rapidly in the other direction to a maximum peak, I_p .

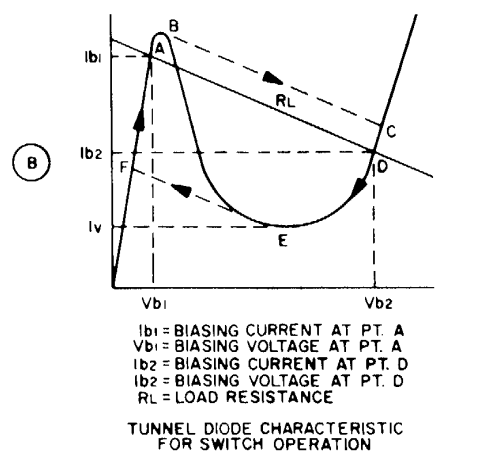
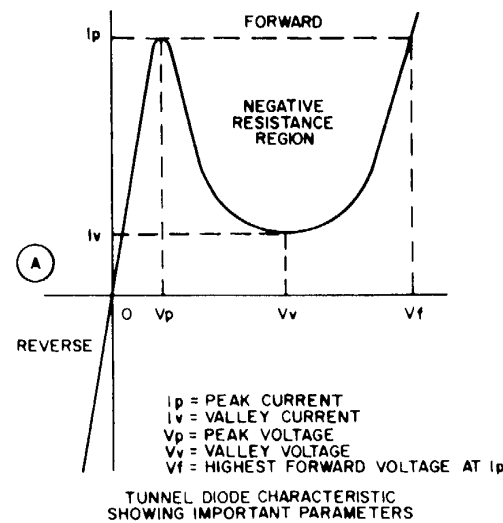

ORD G350288

Figure 3-3. Tunnel diode characteristic.

(b) As the forward bias increases to various intermediate values (from V_p to V_v), the current decreases to a deep minimum valley at point I_v . This represents the important negative resistance characteristic of the tunnel diode. At higher

values of forward bias, the tunnel diode again functions as a conventional diode. The negative-resistance characteristic (increasing the forward bias to cause a decrease in current) enables the tunnel diode to amplify, oscillate, and function as a switch.

(c) How the tunnel diode functions as a switch (this is how it operates in the trigger circuit) is discussed below. In figure 3-3B, a load line has been chosen that intersects the two positive regions of the curve at points A and D. These points represent the tunnel diode's two stable states: a high current, low voltage state, and a lower current, high voltage state.

(d) Assume that the tunnel diode is forward-biased at point A (this point represents the setting of the LEVEL control). If a further negative potential is applied to the tunnel-diode cathode, the current increases and it switches to high-voltage point C. When the current no longer increases (stabilizes), the biasing point falls back from C to D (the low current, high voltage stable state) on load line RL.

(e) To bring the tunnel diode back to the low voltage, high current point (initial stable state), the biasing current is momentarily reduced to a value less than the valley current by a positive potential applied to the cathode. The tunnel diode thus switches to point F and then up to point A, the starting point (also on load line RL).

(f) Returning to the difference amplifier circuit, notice that TRIG SENS resistor R8229 is connected across the tunnel diode. With this circuit configuration you can vary the current through the tunnel diode. You adjust the TRIG SENS resistor to set the current through the tunnel diode to its optimum operating point (as close to point I_p as possible).

(g) TRIG BAL resistor R8234 (zone B6) sets the voltage level (reverse bias) that the difference-amplifier negative output must overcome to forward-bias the tunnel diode. You adjust the TRIG BAL, resistor while LEVEL control R8222 is set at zero. When the TRIG BAL resistor is properly adjusted, the SLOPE switch can be changed from plus to minus; the output of the difference amplifier will still overcome the reverse-bias voltage level without readjusting the LEVEL control.

(h) Inductor L8201, connected in series with the TRIG SENS resistor and in parallel with the tunnel diode, provides the high-impedance load required of the tunnel diode. The inductor increases the pulse amplitude.

(3) *Shaping.* The output of the difference amplifier and tunnel diode goes to differentiating amplifier Q8202. This stage differentiates (shapes) the signal, converting it into a sharp trigger pulse which is applied to transformer T8201 (zone A7). After passing through trigger diode CR8203, the negative-trigger output of T8201 goes to normal-sweep gate multivibrator Q8206, Q8207 (par. 3-13).

e. Automatic Triggering.

(1) From the description in *d* above, you can see that an input signal is used to generate a trigger pulse. However, there are occasions where it is desirable to produce a trigger pulse without an internal signal. When the automatic trigger circuit is employed, a reference trace is displayed on the CRT, regardless of whether a signal is applied to the oscilloscope or not.

(2) Placing the NORM-AUTO switch to AUTO activates the automatic trigger circuit. Automatic trigger amplifier Q8201 (zone B5) is connected between the output (plate of V8201) and input (grid of V8202) of the difference amplifier. RC network R8211, C8207, in the collector circuit of Q8201, generates a triangular waveform which is applied to V8202. Using AUTO SYNC ADJ resistor R8210, you can make the triangular signal symmetrical as well as set its frequency to about 50 cycles.

f. *Delayed Trigger Generation.* The delayed trigger circuit is similar to the normal trigger circuit; therefore, the description given in *d* above will apply to this circuit as well.

3-13. Normal Sweep (Fig. 4-5)

a. Normal Sweep Gate.

(1) After passing through transformer T8201, the negative trigger goes to bistable multivibrator Q8206, Q8207 (the normal-sweep gate multivibrator) via trigger diode CR8203. In its initial state, transistor Q8206 is conducting and Q8207 is cut off. The negative trigger pulse applied to Q8206 then cuts it off. This causes Q8207 to conduct, and the operating state of the multivibrator changes. In this new operating state, positive output appears at the collector of Q8206 and a negative output appears at the collector of Q8207. Trigger diode CR8203 and the lockout circuit, (d below), prevent the triggering of the multivibrator until after the sweep is completed.

(2) The negative output from Q8207 goes to the sawtooth generator via diode-clamp CR8212, disconnect diodes CR8205, CR8209, CR8211, CR8216, and diode CR8213. The positive output from Q8206 goes to delayed-sweep gate multivibrator Q8106, Q8107 (zone D9), and unblanking amplifier Q8405 (zone D13). The length of time that the normal-sweep gate multivibrator remains in this particular state depends on the duration of the sawtooth generator output (b below). When the sawtooth reaches its maximum output, it causes turn-off diode CR8204 to conduct, causing the multivibrator to change state.

b. Sawtooth Generator.

(1) The sawtooth generator is a Miller integrator (V8203) coupled to a cathode follower (V8204). Since this is not the type of circuit you see with any regularity, let's take a closer look at it. Figure 3-4A is a simplified schematic of the sawtooth generator.

(2) First, assume that the sweep gate multivibrator hasn't been triggered, and, therefore, it sends a positive signal to disconnect diodes, forward-biasing them. Although the simplified schematic shows only two diodes, there are actually four,

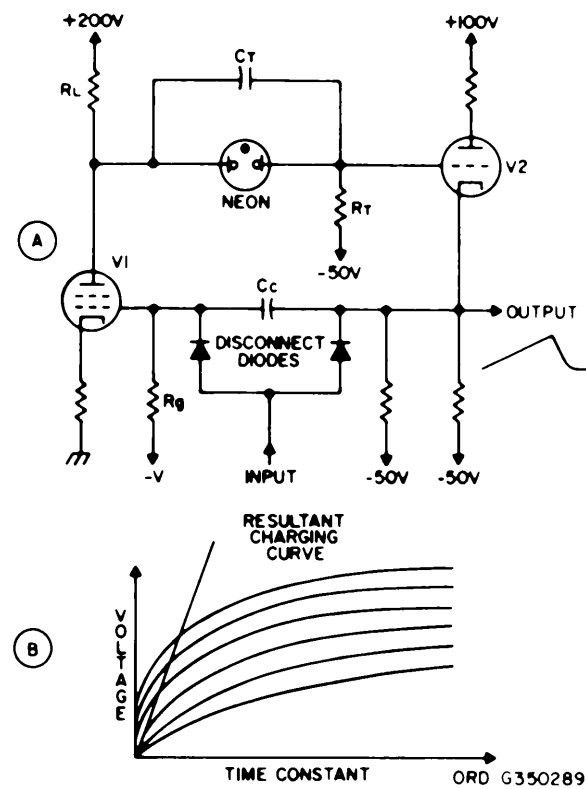

Figure 3-4. Miller integrator (run-up) circuit.

CR8205, CR8209, CR8211, and CR8216. With both diodes conducting, charging-capacitor Cc (actually a capacitor which you select with TIME/DIV switch S850) is short-circuited. In addition, the grid of V1 (V8203) and the cathode of V2 (V8204) are clamped to a small negative voltage (approximately -2 volts) by diode-clamp CR8212 via diode CR8213 and the disconnect diodes.

(3) Timing capacitor Ct charges to the plate voltage of V1 via resistor RT. Assume that this voltage becomes large enough to fire the neon bulb connected across the capacitor. Since the neon bulb drops approximately 50 volts, this will be the final charge across the capacitor.

(4) When the sweep gate multivibrator is triggered, a negative signal is applied to the disconnect diodes, reverse-biasing them. This removes the short circuit across capacitor Cc and the clamping voltage from the grid of V1 and the cathode of V2.

(5) Removing the clamping voltage causes the grid of V1 to go more negative and its plate voltage to increase. Since the neon bulb drops a constant 50 volts, a higher potential is applied to the grid of V2.

(6) Since V2 is a cathode follower, its cathode is at approximately the same potential as its grid. Capacitor Cc, connected to the cathode, starts charging to the grid potential. Its charge path is through resistor Rg and V2. As Cc charges, it forces the grid of V1 to go more negative, resulting in an even larger plate voltage. The grid of V2 then receives this higher voltage via the neon bulb. This process continues until the negative potential (sweep gate multivibrator output) is no longer applied to the disconnect diodes. Notice that as the voltage, to which the charge on capacitor Cc increases, the slope of the charging curve becomes straighter (more linear). Figure 3-4B illustrates this. Since the output is taken from the cathode of V2, to which Cc is connected, the time constant of Rg and Cc determines the angle of the slope or ramp. Notice that for capacitor Cc to charge linearly, a constant current must be applied to it. Cathode follower V2 acts as a variable resistor and provides this function. With a linear voltage applied to its grid, the resistance exhibited by V2 also varies linearly, producing a constant current. When the charge on the disconnect diodes is reversed by a gate from the normal-sweep gate multivibrator, capacitor Cc is shorted and discharges. The circuit is then ready to begin another cycle, as described in c (3) below.

(7) The circuit through which capacitor Cc charges is shown in figure 4-5 (zone A10). Setting TIME/DIV switch S850 to the desired position (any one of 23 positions), you select the proper values of Rg and Cc to produce the desired time constant. This is illustrated by a single resistor-capacitor combination in the functional schematic.

(8) Assuming that the TIME/DIV switch is set to the desired position, then capacitor Cc starts charging when the disconnect diodes are reverse-biased. Remember that the charging path for Cc was via resistor Rg and cathode follower V2 (V8204). Looking at the functional schematic, note that resistor Rg is also connected to emitter follower Q8204, which is the source of negative potential from which capacitor Cc charges. SWEEP CAL, and SWEEP VERNIER resistors R824R and R8242, respectively, are connected to the base of Q8204 via DISPLAY LOGIC switch S840, and control the operating level of the emitter follower. This, in turn, determines the amplitude of the negative potential.

(9) Continuing with the signal flow, the positive-going output of the sawtooth generator goes to the horizontal deflection amplifier (par. 3-15) via RC attenuator R8623, C8606 and the DISPLAY LOGIC switch. In addition to the horizontal deflection amplifier, the sawtooth voltage also goes to turn-off emitter follower Q8208 (zone A8) and comparator Q8601, Q8602 (zone B10).

c. Sweep Duration.

(1) The width of the negative-gate output, from the normal-sweep gate multivibrator, determines the duration of the sawtooth-generator output. The positive ramp output of the sawtooth generator, in conjunction with turn-off emitter follower Q8208 and SWP LENGTH resistor R8263 controls the duration of the negative gate.

(2) Turn-off emitter follower Q8208 receives the positive-going ramp from the sawtooth generator. After passing through the emitter follower, the ramp voltage goes to turn-off diode CR8204. Adjusting SWP LENGTH resistor R8263 in the emitter circuit of Q8208 varies the dc operating level of the ramp voltage. Since diode CR8204 is normally reverse-biased, the normal-sweep gate multivibrator tends to remain in its activated state, producing a negative output. With the SWP

LENGTH resistor set to provide the proper dc operating level, the positive-going ramp signal will overcome the reverse-bias voltage applied to CR8204 at the right time (halfway between the last graticule marking and the end of the CRT face).

(3) When the turn-off diode conducts, a positive voltage is applied to the base of normal-gate sweep multivibrator transistor Q8206. This positive voltage drives Q8206 into saturation, rapidly returning the multivibrator to its original operating state. You will recall that in this state, the multivibrator produces a positive output, causing the disconnect diodes to conduct, which, in turn, deactivates the Miller integrator circuit. Charging capacitor Cc (fig. 3-4A) is short-circuited and discharges; the Miller integrator circuit is then ready for the next sweep cycle after completion of the lockout time interval (d below).

d. Lockout Circuit.

(1) The lockout circuit prevents the triggering of the normal-sweep gate multivibrator to occur during the sweep retrace interval. Although the disconnect diodes (when forward-biased) short-circuit the charging capacitor, they still offer some resistance to the capacitor current; preventing the capacitor from discharging at once. The time it takes the capacitor to discharge to its quiescent level (-2 volts), is the sweep retrace time. Since you don't want the sawtooth generator activated before the retrace time of the sawtooth signal is completed, you must prevent the normal-sweep gate multivibrator from being triggered during this interval. Figure 3-5 is a simplified schematic of the lockout circuit.

(2) You will recall in paragraph a above that trigger diode CR8203 and the lockout circuit prevent the triggering of the normal-sweep gate multivibrator during the forward sweep interval. Let's see how they perform this function. The sawtooth output of turn-off emitter follower, Q8208, besides going to turn-off diode CR8204, is also applied to diode CR8206 (zone A8)

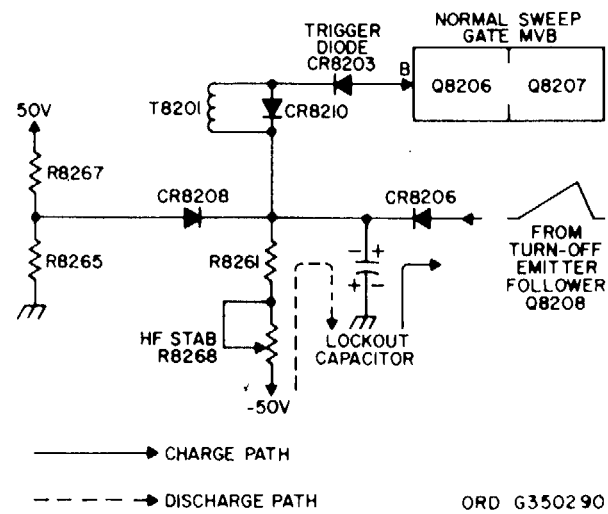

Figure 3-5. Lockout circuit, simplified schematic.

causing it to conduct. With CR- 8206 conducting the lockout capacitor (selected by the setting of TIME/DIV switch S850) charges to this linear increasing voltage (shown by the solid line in fig. 3-5). As the lockout capacitor charges, a positive-going ramp voltage goes to trigger diode CR8203 via transformer T8201. This voltage reverse-biases the diode sufficiently to prevent any unwanted trigger pulses from changing the operating state of the normal-sweep gate multivibrator. When the sawtooth output of Q8208 is not present, voltage divider R8265, R8267 forward-biases diode CR8208, preventing the -50 volts applied to HF STAB resistor R8268 and resistor R8261 from forward-biasing trigger diode CR8203.

(3) You will recall that when the ramp voltage reaches its predetermined height (full sweep trace), turn-off diode CR8204 conducts, causing the normal-sweep gate multivibrator to change state, thus applying a positive voltage to the disconnect diodes. As previously stated, this will deactivate the Miller integrator and result in sweep retrace. During the retrace interval, the lockout capacitor discharges through resistor R8261 and HF STAB control R8268 (as shown by the

dashed line in fig. 3-5). The lockout capacitor doesn't fully discharge until the retrace time interval is completed. Therefore, trigger diode CR8203: is kept reverse-biased by the decreasing positive voltage from the lockout capacitor via diode CR8210 and transformer T8201 during the retrace time interval. This prevents the normal sweep gate multivibrator from being triggered.

(4) In summary, the ramp output of the turn-off emitter follower reverse-biases trigger diode CR8203 during the forward sweep interval, preventing any unwanted trigger pulses from changing the operating state of the normal-sweep gate multivibrator. And, although the charge on the lockout capacitor is decreasing during the sweep retrace, it is still large enough to keep the trigger diode reverse-biased, and continues to prevent any unwanted trigger pulses from changing the operating state of the normal-sweep gate multivibrator.

e. HF Stability (Recurrent Sweep). When you wish to observe very high frequency signals (5 megacycles or higher), you rotate the HF STAB control R8268 counterclockwise, setting RECUR-NORM switch S825 to the RECUR position. This places a ground at the anode of CR8208 and reverse-biases the diode. You will recall that the lockout capacitor discharges through R8261 and the HF STAB control. Therefore, by rotating the HF STAB control you can vary the duration of the lockout time (the time interval that prevents the unwanted trigger pulses from triggering the normal-sweep gate multivibrator). Rotating the HF STAB control counterclockwise decreases the discharge time of the lockout capacitor, which in turn shortens the lockout time. Notice that by shortening the lockout time, you increase the natural frequency of the sawtooth generator. It can also be set so that exact submultiples of the high trigger frequency (dual trace plug-in or external input) can be chosen. Being able to choose the proper submultiples provides stable synchronization of very high frequencies (5 to 50 megacycles).

f. Beam Gate Circuit.

(1) This oscilloscope uses a cathode-ray tube (CRT) that has two additional deflecting plates and a blanking shield (baffle) with a center aperture. The blanking shield is located in front of the beam deflecting plates (the CRT face side). The aperture is used to cut off the electron beam without regard to the potential on the CRT control grid. During the forward sweep interval the electron beam passes through the aperture of the blanking shield because both deflection plates are kept at the same potential. Upon completion of the sweep, during the retrace interval, one of the deflection plates receives a larger potential than the other, creating a potential unbalance between the plates. This unbalance causes the electron beam to

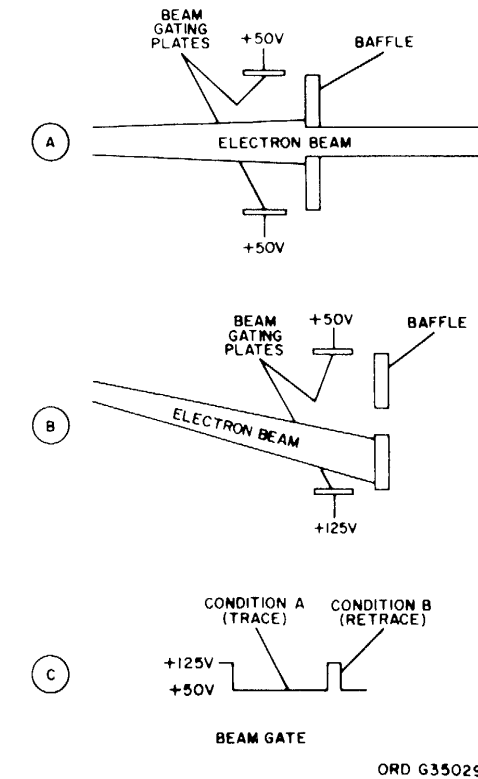

Figure 3-6. Beam gate effect.

deflect toward the plate with the larger positive potential. After passing through the plates, the deflected beam strikes the shield instead of going through the aperture. This produces the desired result of blanking the CRT screen preventing signal display) during the retrace and lockout time. In order to obtain the blanked condition there must be at least a 75-volt potential difference between the beam gating plates. Figure 3-6a, b, and c illustrates the unblanked and blanked condition just described.

(2) The positive output (gate), taken from Q8206 of the normal-sweep gate multivibrator, is applied to unblanking cascode amplifiers Q8405, Q8403 (zone D14). This gate coincides with the ramp (sweep) output of the sawtooth generator. After passing through the unblanking amplifiers, the gate goes to emitter follower Q8402. Voltage divider R8412 and R8113: establishes a 15-volt operating potential for amplifier Q8403. Emitter follower Q8401 is the B+ operating voltage source for Q8402. It produces a +125-volt output, limiting the collector potential of emitter follower Q8402 to this value. Therefore, the negative-gate output of the unblanking amplifiers (approximately 75 volts peak to peak), after passing through Q8402, operates between voltage levels of +50 and +125 volts, and it is applied to one of the beam gating plates (pin 6). With the oscilloscope in the normal sweep mode (DISPLAY LOGIC switch S840 at NORM), the other beam deflection plate (pin 13) receives a constant +50-volt potential via resistor R2028.

(3) Remember that a 75-volt difference between the beam-gating plates is required to remove the display from the CRT screen. When the output of emitter follower Q8402 is maximum, the voltage difference between the plates is 75 volts (+125 to +50 volts) and the CRT screen is blank. (This occurs during retrace and lockout time.) During the time interval the output of Q8402 is minimum (negative gate), there is no voltage difference between the plates: a sweep trace or signal, as the case may be, appears on the CRT screen (during forward sweep time).

(4) The negative-gate output of emitter follower Q8402 also goes to differentiator C8441, R8442, R8443. The differentiated output provides the proper trigger to the blanking multivibrator in the dual trace plug-in (par. 3-9).

g. Summary.

(1) Before going into a description of the delayed sweep circuitry (par. 3-14), let's briefly summarize the generation of the trigger pulse and sawtooth signals. The waveforms in figure 3-7 are used to cover the main points of preceding detailed description.

(2) The first waveform (assuming a sine-wave signal) shows the input signal that passes through the various

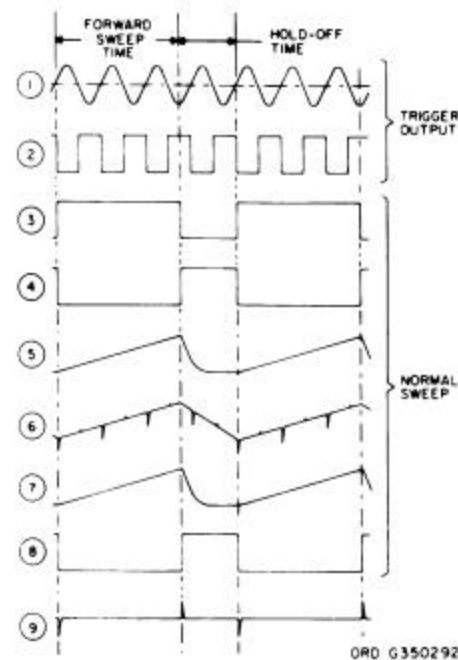

Figure 3-7. Triggering and normal sweep waveforms.

triggering switches to the difference amplifier. At the output of the amplifier, we observe the second waveform, a series of symmetrical pulses. The squaring of the original sine-wave input is the result of the tunnel-diode action.

(3) When the pulse output of the difference amplifier triggers the normal-sweep gate multivibrator, positive and negative gates are produced, as shown by waveforms 3 and 4. The negative gate reverse-biases the disconnect diodes, activating the Miller integrator circuit which produces the linear sawtooth output shown by waveform 5. The sawtooth output goes to the horizontal deflection amplifiers.

(4) To prevent premature triggering of the normal-sweep gate multivibrator, the output of the turn-off emitter follower keeps the trigger diode reverse-biased. Waveform 6 shows that although negative triggers are applied to the trigger diode, the positive sawtooth and lockout circuit outputs are large enough to keep the diode reverse-biased for the required time interval. Notice that during the hold-off time, the linear-rising ramp doesn't return to its initial operating level immediately. This is the retrace interval where the lockout circuit functions, preventing premature triggering. Waveform 7 shows output of the turn-off emitter follower, that forward-biases the turn-off diode, to trigger the normal-sweep gate multivibrator back to its original operating state.

(5) The positive-gate output of the normal-sweep gate multivibrator goes to the unblanking amplifiers in the beam gate circuit. After it is inverted, the negative gate, as shown by waveform 8, passes through an emitter follower to a beam gate deflection plate. During the period the gate is negative (forward-sweep time) the CRT is unblanked. When the gate becomes positive (retrace time), the CRT is blanked.

(6) Besides going to the beam gate deflection plate in the CRT, the emitter follower output is differentiated (waveform 9) and sent to the dual trace plug-in. This differentiated signal provides the proper trigger for the blanking multivibrator in the dual trace plug-in.

3-14. Delayed Sweep (Fig. 4-5)

The delayed sweep circuitry, operating in conjunction with the normal sweep circuitry, provides us with four more operating modes. These modes are: triggered-strobe, triggered-delayed, armed-strobe, and armed-delayed.

a. Triggered-strobe.

(1) In this mode, a segment (strobe) of the sweep displayed on the CRT appears brighter. To accomplish this, the delayed sweep circuitry is activated during the normal sweep interval. This, in a sense, superimposes the delayed sweep on the normal sweep. The start of this brightened segment represents the start of the delayed sweep; the length of the segment represents the length of the delayed sweep.

(2) Setting DISPLAY LOGIC switch S840 to TRIG-STROBE activates the delay trigger pick-off circuit (consisting of comparator Q8601, Q8602, emitter follower Q8603, differentiator amplifier Q8604, transformer T8601, and DELAY VERNIER control R8617), the delayed sweep circuit, and the strobe circuit (Q8001, Q8002). In this mode, the normal sweep (delaying sweep) operates as described in paragraph 3-13.

(3) The normal sweep signal from sawtooth generator V8203, V8204 is applied to comparator Q8601, Q8602 via diode CR8602 (zone B10). The other input to the comparator is a dc voltage that is determined by the setting of the SWEEP CAL, DELAY VERNIER, and DELAY ZERO controls, R8241F, R8617, and R8618, which form a voltage divider. This fixed voltage is applied to the comparator via emitter follower Q8603 and diode CR8603. The comparator circuit functions in the

same way as the difference amplifier described in paragraph 3-12d (trigger generation). Each of these circuits employs a tunnel diode to produce a squared pulse output. Although a sawtooth signal is used instead of a sine wave, it doesn't alter the operation of the circuit.

(4) Amplifier Q8604, resistor R8621, and capacitor C8611 differentiate the square-wave output of the comparator circuit, and apply it to transformer T8601. Because of the transformer winding configuration, you will notice that the positive pulse, representing the leading edge of the comparator circuit output, when applied to diode CR8105, becomes a negative pulse. Passing through the diode, the negative pulse triggers delayed-sweep gate multivibrator Q8106, Q8107. The negative gate output of the delayed-sweep gate multivibrator activates the sawtooth generating circuit (V8103, V8104), which is identical to the one described in paragraph 3-13a through d.

(5) Before continuing with this description, let's cover the method of balancing both the normal- and delayed- sweep circuits to produce identical sweep rates. Notice that the negative gates from the normal- and delayed- sweep gate multivibrators, that remove the clamping voltage from the grids of the Miller integrators via the reverse-biased disconnect diodes, also remove the clamping voltage from the Miller integrator cathodes by reverse-biasing diodes CR8213 and CR8109 (zones A10 and D10). With both sweep circuits activated, SWP RATE BAL resistor R8175 (connecting both Miller integrator cathode circuits) (zone C11) is adjusted so the conduction through the tubes (V8203, V8103) is approximately the same. You make this adjustment so that both the normal and delayed sweep circuits produce the same sweep rates at identical settings of the TIME/DIV switch.

(6) Continuing with the description of the triggered-strobe mode, notice that only the normal sawtooth generator output goes to the horizontal deflection amplifier circuit. In order to obtain the strobe effect, a portion of the displayed signal must appear narrower, and brighter. This is accomplished by setting the DELAYED SWEEP TIME DIV switch to a shorter time period than the setting on the normal sweep TIME/DIV switch.

(7) The positive gate output of the delayed-sweep gate multivibrator goes to strobe circuit Q8001, Q8002 and to the beam gate circuit (par. 3-13f). Amplifier Q8001 (zone C14) inverts the positive gate and applies it to the amplifier Q8002. Here, the gate is amplified and again inverted. The resultant positive gate (A, fig. 3-8), having a 30-volt amplitude, is applied to the beam gate plate (pin 13). (During the normal sweep mode this beam gate plate had a constant 50-volt potential

applied to it.) STROBE ADJ resistor R8012 controls the dc level of the strobe circuit output.

(8) The positive gates from the normal-sweep gate multivibrator and delayed-sweep gate multivibrator (B and C, fig. 3-8) are applied to unblanking (cascode) amplifiers Q8404 and Q8405 (zones C13, C14). The outputs of these two amplifiers are combined, and applied to unblanking amplifier Q8403. The resultant negative-going output of the unblanking amplifiers, (D, fig. 3-8) having an overall 75-volt amplitude, is applied to emitter follower Q8402. The output from emitter follower Q8402 is applied to the beam gate plate (pin 6) and is shown by waveform E of figure 3-8.

(9) Referring to figure 3-8, you see that during the interval represented by t_1 , 50 volts is applied to the beam gate plate (pin 6). The other beam gate plate (pin 13) receives the output of strobe circuit, which during this interval generates a constant voltage (approximately 20 volts) because the delayed-sweep gate multivibrator hasn't been activated yet. Now the potential difference between the plates (approximately 30 volts) is such, that the electron beam is deflected by an amount that allows only a portion of it to pass through the aperture of the shield. This reduces the brightness of the CRT display.

(10) During the interval represented by t_2 , both deflection plates receive approximately the same potential (50 volts). It is during this interval that the delayed-sweep gate multivibrator is activated, causing the strobe circuit to produce a positive gate. With both beam gate plates at the same potential, the entire electron beam passes through the aperture, producing a brighter CRT display.

(11) Upon completion of interval t_2 , the delayed sweep gate multivibrator is deactivated. At the same time, the strobe circuit goes back to its initial operating state, producing a constant output (approximately 20 volts). Thus, we see that the potentials applied to the beam gate plates during the intervals represented by t_1 and t_3 are the same. This results in a dimmer CRT display.

(12) Paragraphs (9) through (11) above described conditions where it is assumed the delayed sweep ends some time during the normal sweep interval. However, suppose you adjust the DELAY VERNIER control so that the delayed sweep starts near the end of the normal sweep. Let's further assume that the duration of the delayed sweep extends beyond the end of the normal sweep. Under these conditions, the retrace of the normal sweep would be displayed and appear bright; this is undesirable. To prevent this from happening, the positive-gate output of the normal-sweep gate multivibrator is used to return the delayed-sweep gate multivibrator to its initial operating state.

(13) The positive-gate output of the normal-sweep gate multivibrator (Q8206) is differentiated by RC network C8126, R8157 (zone C9), resulting in positive and negative pulses that are applied to diode CR8107. The diode allows only the negative pulse, representing the trailing edge of the gate, to pass, triggering the delayed-sweep gate multivibrator. Returning to its initial operating state, the delayed-sweep gate multivibrator output deactivates the delayed sawtooth generator, cutting off the delayed sweep. At the same time, the strobe circuit produces a constant output (approximately 20 volts). With the output of emitter follower Q8402 (a level of 125 volts) and the constant output of the strobe circuit applied to the beam gate plates, there is more than the required 75- volt potential difference to prevent the electron beam from passing through the aperture on the shield.

(14) An effect may appear where the bright segment (strobe), instead of being coincident with the trace on the CRT

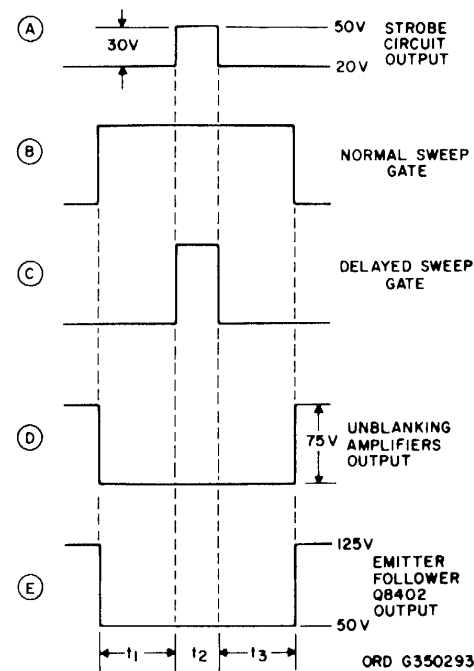

Figure 3-8. Beam gate plate input waveforms (triggered-strobe mode).

screen, falls on either side of the trace (horizontally). To correct this effect, we adjust STROBE PATT CORR variable resistor R8005 (zone C15) and trimmer capacitor C8004 in the collector circuit of strobe amplifier Q8002.

(15) Let's briefly summarize the detailed description of the triggered-strobe mode, using the waveforms in figure 3-9. The first waveform shows the output of the normal sawtooth generator that goes to the horizontal deflection amplifier and the comparator stage in the delay trigger pick-off circuit. After comparing the normal sawtooth with a fixed voltage determined by the DELAY VERNIER control, the comparator produces a squared output (waveform 2) which is a result of the tunnel diode action. Waveform 3 shows the inverted-differentiated output of the differentiating amplifier that is applied to the delayed-sweep gate multivibrator after it passes through a pulse transformer and a diode.

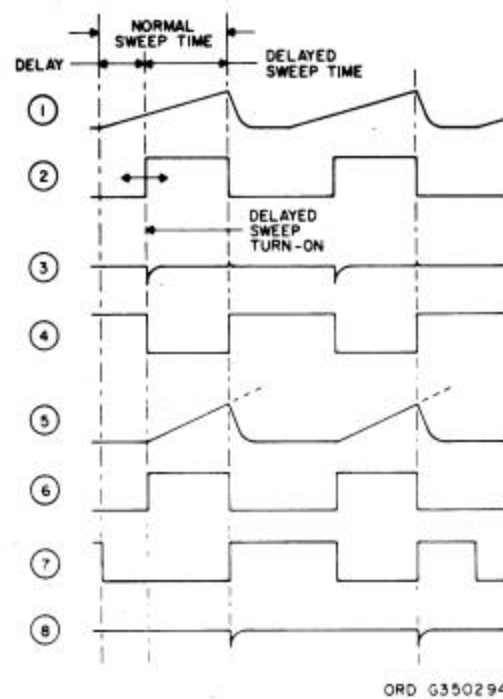

Figure 3-9. Triggered-strobe mode waveforms.

(16) The negative-gate output of the delayed-sweep gate multivibrator, shown in waveform 4, activates the Miller integrator circuit, producing a sawtooth signal (waveform 5) that is terminated at the DISPLAY LOGIC switch. At the same time, the positive-gate output of the delayed-sweep gate multivibrator is applied to the strobe circuit. This circuit produces a strobe pulse that has the same duration as the delayed sweep and is shown by waveform 6. One of the CRT beam gate plates receives the strobe pulse.

(17) Waveform 7 illustrates the resultant output of the unblanking amplifiers after they receive the positive gates from the normal- and delayed-sweep gate multivibrators. This signal, after passing through an emitter follower, is applied to the other CRT beam gate plate. During the time the beam gate plates are at the same potential, the CRT presents a bright display. In the interval when the difference between the deflection plate potentials is some intermediate value (below cutoff) the CRT display is dimmer.

(18) To make sure the retrace isn't displayed, the positive-gate output of the normal-sweep gate multivibrator is differentiated and applied to the delayed-sweep gate multivibrator. The negative pulse of the differentiated signal (waveform 8), representing the trailing edge of the positive gate, triggers the delayed-sweep gate multivibrator, which in turn, deactivates the delayed sawtooth generator. In addition, the strobe circuit no longer receives the positive gate, and therefore, a strobe pulse isn't generated. With the delayed-sweep gate multivibrator in its initial operating state and the strobe pulse not being generated, the potential difference between the beam gate plates is such that it prevents the electron beam from reaching the CRT screen.

b. Triggered-delayed.

(1) In this mode, the bright segment of the CRT display in the triggered-strobe mode is expanded to cover the full screen. The amount of expansion is proportional to the ratio of the normal sweep rate to the delayed sweep rate.

(2) With the DELAY LOGIC switch set at TRIG-DLY'D, the delayed sawtooth generator output, rather than the normal sawtooth generator output, is sent to the horizontal deflection amplifier. The circuitry described in paragraph a above for the triggered-strobe mode is also used in the triggered-delayed mode. The circuits operate in exactly the same way except that in this mode the strobe circuit is deactivated and has no effect on the CRT display.

(3) In addition, when the delayed sweep is completed, the normal sweep is automatically terminated. This increases its duty cycle to the optimum value. As an example, suppose the normal sweep is 2 seconds long; the delayed sweep is 50 milliseconds; and the time (delay) until the delayed sweep starts is 50 milliseconds, as shown in figure 3-10 (a) and (b). You can see, if the normal sweep isn't terminated at the completion of the delayed sweep, we will have to wait approximately 2 seconds (1950 milliseconds) before we can again observe a display on the CRT screen. This is undesirable since it doesn't permit continuous display of the signal on the CRT screen.

(4) To make sure the display is continuous, the positive output of the delayed-sweep gate multivibrator triggers the normal-sweep gate multivibrator to its initial operating state. The positive-gate output of the delayed-sweep gate multivibrator is differentiated by RC network C8216, R8217 (zone A9). Diode CR8202 passes only the negative pulse (representing the trailing edge of the positive gate and the end of the delayed sweep), which triggers the normal-sweep gate multivibrator to its initial operating state.

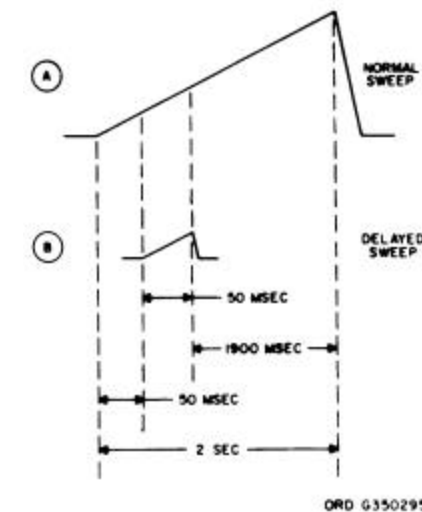

Figure 3-10. Comparison of normal sweep to delayed sweep.

c. Armed-strobe.

(1) In this mode the delayed sweep doesn't start at the end of the selected delay interval until a trigger pulse via the triggering circuitry (par. 3-12) is applied to the delayed sweep circuitry. The trigger signal can be either the input to the oscilloscope (dual trace plug-in output), or a trigger signal from an external source. Setting the DISPLAY LOGIC switch to ARMSTROBE activates all the circuitry described in paragraphs a and b above with the addition of the armed multivibrator circuit (zone C7). The armed multivibrator prevents premature triggering of the delayed-sweep gate multivibrator.

(2) You will recall that the setting of DELAY VERNIER control R8617 (zone B11) determines the delay interval, the time between the start of the normal sweep and the generation of a gate by the comparator circuit. You will also recall that this output is differentiated by Q8604, R8621, and C8611 and is applied to transformer T8601. Diode CR8104 passes the

negative-pulse output of transformer T8601 (representing the leading edge of the comparator Q8601, Q8602 output) to armed multivibrator Q8103, Q8104. In addition, a negative-pulse output from T8601 goes to diode CR8105. Resistors R8145 and R8135 form a voltage divider and since they are of equal value, a positive 25-volt potential at their junction is applied to diode CR8105, reverse-biasing it. Reverse-biasing the diode prevents the negative pulse from passing through CR8105 to trigger the delayed-sweep gate multivibrator.

(3) You will notice that there is also a voltage divider (R8146, R8147) at the pulse-input side (cathode) of diode CR8104. However, the value of R8147 is negligible compared to R8146, and the network produces a very small positive voltage which the negative pulse can easily overcome to trigger the armed multivibrator. Capacitor C8122 shunts any transient pulses that may be generated.

(4) In its quiescent state, Q8103 of the armed multivibrator is cut off and Q8104 is conducting. With Q8103 cut off, a positive voltage (gate) is applied to armed lockout diode CR8102, reverse-biasing the diode. In this state, the diode prevents any incoming trigger signals from firing the delayed-sweep gate multivibrator. At the same time, switching transistor Q8102 (zone D7) receives the positive output from the armed multivibrator and conducts heavily. When the switching transistor conducts, SWP READY lamp DS8101 is shunted to ground, preventing the lamp from lighting.

(5) When the negative pulse output of transformer T8601 passes through diode CR8104, it triggers the armed multivibrator, changing the operating state of the multivibrator. In this state, Q8103 conducts and Q8104 is cut off. Now armed lockout diode CR8102 receives a negative voltage and becomes forward-biased. Forward-biasing the armed lockout diode opens the trigger circuit, making it possible for the next trigger signal to fire the delayed-sweep gate multivibrator and start the delayed sweep. The delayed sweep circuit as well as the strobe circuit operate in exactly the same way as described in a above.

(6) In addition to forward-biasing diode CR8102, the negative-voltage output of the armed multivibrator cuts off switching transistor Q8102. With the transistor cutoff, the SWP READY lamp is no longer shunted to ground and it lights. This indicates that the delayed-sweep gate multivibrator is *armed* and will fire upon receiving the next trigger signal.

(7) When the delayed-sweep gate multivibrator is triggered, it produces a negative-gate output at Q8107. The negative-gate is then differentiated by C8118, R8143 (zone D8) and the negative pulse, representing the leading edge of the gate, passes through diode CR8103 to trigger the armed multivibrator. When the armed multivibrator is triggered, it reverts to its original operating condition.

(8) Let's briefly summarize the detailed description of the armed-strobe mode, using the waveforms in figure 3-11. The first waveform shows the output of the normal sawtooth generator that goes to the horizontal amplifier and the comparator stage in the delay trigger pick-off circuit. Waveform 2 shows the inverted-differentiated output of the differentiating amplifier, which triggers the armed multivibrator after passing through a pulse transformer and a diode. When the armed multivibrator fires, it produces a negative gate, shown in waveform 3, which forward-biases- (unlocks) the armed lockout diode. This permits the next trigger to fire the delayed-sweep gate multivibrator.

(9) When the delayed-sweep gate fires, the negative-gate output, as shown by waveform 4, goes to the delayed sweep Miller integrator via the disconnect diodes, and to the armed multivibrator via a differentiator network and a diode. The negative pulse of the differentiated signal, shown by waveform 5, triggers the armed multivibrator, reverting it to its initial state.

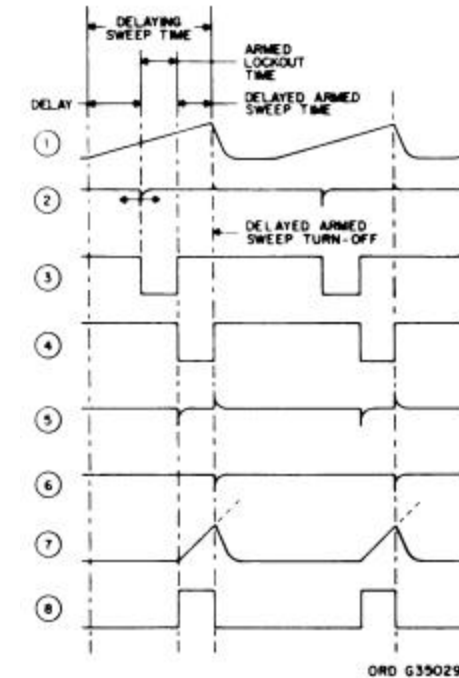

Figure 3-11. Armed-strobe mode waveforms.

(10) Waveform 6 shows the negative turnoff trigger pulse, representing the differentiated trailing edge of the positive gate from the normal-sweep gate multivibrator, after it passes through a differentiator and a diode. This negative pulse triggers the delayed-sweep gate multivibrator, which in turn, deactivates the delayed sawtooth generator. The ramp output of the delayed sweep generator that goes to the horizontal amplifier is shown by waveform 7. Waveform 8 shows the output of the strobe circuit, which is activated by the positive-gate output of the delayed-sweep gate multivibrator.

d. *Armed-delayed.*

(1) In this mode only the delayed sweep is applied to the horizontal deflection amplifier, and the bright segment of the CRT display in the armed-strobe mode now covers the entire screen. In addition, the strobe circuit is deactivated, so that the signal displayed on the screen will have the same brightness as when the signal is displayed in the normal sweep mode. The circuitry described in c above is also used in this mode except that the strobe circuit is now deactivated.

3-15. Horizontal Deflection Amplifier (Fig. 4-5)

The horizontal deflection amplifier operates in exactly the same way for all sweep modes (including the substitution of an external signal source for the internally generated sweep signal). This circuit will be described for only two modes, normal sweep and external sweep (X amplifier input).

a. *Normal Sweep Amplification.*

(1) With the DISPLAY LOGIC switch at NORM, the sawtooth output from the normal sweep generator (Miller integrator V8203, V8204) passes through the switch to emitter follower Q8301 (zone A13). POSITION control R8306, R8307, a dual-variable resistor, determines the point at which the sweep display appears on the CRT screen by controlling the operating level of emitter follower Q8301. Emitter follower Q8304 provides a 23-volt operating level for Q8301.

(2) After passing through Q8301, the sawtooth signal goes to parphase amplifier Q8302, Q8303. The parphase amplifier (common-emitter amplifier) produces two outputs, equal in amplitude and 180 degrees out of phase, from a single-ended input (Q8301). With PULL X10 switch S830 in its normal position (pushed in), attenuator R8329, C8309 (zone B15) with a ratio of 10 to 1, becomes part of the common-emitter circuit of the parphase amplifier. This circuit reduces the

outputs of the paraphase amplifiers before they go to emitter followers Q8305 and Q8306. If the PULL X10 switch is pulled, the 10 to 1 attenuator is switched out of the paraphase amplifier emitter circuit and attenuator R8316, C8304, C8303 (zone B14), having a ratio of 1 to 1, is switched into the emitter circuit. With the 1 to 1 attenuator in the emitter circuit, the outputs of the paraphase amplifiers are magnified 10 times before they go to emitter followers Q8305 and Q8306. By pulling the PULL X10 switch, you also insert EXP REG variable resistor R8311 in the base circuit of amplifier Q8303. This resistor controls the operating level of the amplifier. You adjust it to prevent the center of the display from being displaced when the PULL X10 switch is pulled out.

(3) Continuing with our description, assume that the PULL X10 switch is in its normal position (pushed in). After passing through emitter followers Q8305 and Q8306, the push-pull (180 degrees out of phase) outputs of the paraphase amplifiers go to output amplifiers Q8308, Q8309 and Q8307, Q8311. In the output amplifiers, the signals develop the necessary amplitudes to drive the horizontal deflection plates. X AMP LVL variable resistor R8339 controls the operating level of the output amplifiers. Trimmer capacitors C8316 and C8317 of the frequency compensation network in the output amplifier stage are adjusted to correct for any frequency distortion of signals (e.g., rise time and flat top of a square wave) displayed on the CRT screen.

(4) After they are amplified and inverted in the output stage, the push-pull outputs go to the horizontal deflection plates in the CRT. You'll notice that the outputs of the amplifier are applied to beam position indicators (neon lamps) DS8301 and DS8302 before they go to the deflection plates. These lamps indicate the position of the CRT electron beam when the beam is beyond the left or right side of the CRT screen. For example, let's assume the beam is off the screen (right side) and lamp DS8301 is illuminated. To produce this action, the difference between the output of amplifiers Q8308 and Q8307 and the constant 50 volts applied to the lamp exceeds the lamp's firing potential, causing it to illuminate. If the beam is off the screen on the other side (left side), the difference between the output of amplifiers Q8309 and Q8311 and the constant 50 volts causes lamp DS8302 to illuminate. Remember, a lamp will illuminate only when the beam is off the CRT screen. If the beam is within the display area of the CRT screen, the output of the amplifiers will not exceed the lamps firing potential, and both lamps will be extinguished.

b. X Amplifier Only.

(1) If you wish to use an external signal instead of the internally generated sawtooth signal, set the DISPLAY LOGIC switch to X AMP. After connecting the external sweep source to the EXT TRIG-X AMP connector, the external sweep signal passes through PULL EXT 10 switch S813 (zone C1), SOURCE switch S810, COUPLING switch S811, and SLOPE switch S812 to difference amplifier V8101, V8102. With the DISPLAY LOGIC switch at X AMP, tunnel diode CR8101 is switched out of the amplifier plate circuit, the short across X AMP ATTEN variable resistor R8111R (zone D6) is removed, and the short across V8102 plate resistor R8122 is removed; now the difference amplifier becomes the X input amplifier. The X AMP ATTEN resistor controls the operating level of the X input amplifier and also the amplitude of its output.

(2) After it is amplified, the external sweep signal passes through attenuation network R8125, R8130, C8119 (zone

C10) and the DISPLAY LOGIC switch to emitter follower Q8301 (zone A13) in the horizontal deflection amplifier. Here it is amplified in exactly the same way as the internally generated sweep signal (a above).

3-16. CRT (Fig. 4-5)

The CRT circuit consists primarily of the controls which affect the CRT electron beam.

a. Beam Intensity. INTENSITY control R2016 determines the amplitude of the negative voltage (approximately 20 volts) applied to the CRT cathode. By adjusting this control you vary the beam current, resulting in a brighter or dimmer display on the CRT screen.

b. Focusing. FOCUS control R2014 determines the magnitude of the voltage applied to the focusing electrode. You adjust this control until the second convergence point of the electron beam is at the screen of the CRT. When the FOCUS control is set properly, the CRT display will be sharp.

c. Astigmatism. Astigmatism (a defocusing effect) indicates that the electron beam is in focus in the plane of one pair of deflecting plates, but out of focus in the plane of the other pair. To correct astigmatism, a voltage is applied between the accelerator electrode (pin 9) and either pair of deflection plates in such a way as to focus the beam at the same point in both places. ASTIG variable resistor R2022F controls the voltage applied to the astigmatism electrode (pin 11) to focus the beam in both planes simultaneously.

d. Pattern Correction. Since there may be poor linearity at the extremes of deflections, STROBE PATT CORR variable resistor R2009F is provided to correct this fault. By adjusting R2009F, you vary the voltage applied to the pattern adjusting electrode (pin 7), which in turn, varies the electrostatic field produced by this electrode. After the electron beam passes through the deflection plates (vertical and horizontal) it enters the electrostatic field. The STROBE PATT CORR resistor is set until the proper linearity is obtained at the extremes of deflection.

e. Beam Rotate. Since the earth's magnetic field may tilt a trace line appearing on the CRT screen, BEAM ROTATE resistor R2022 and coil L2001 are provided to counteract the influence of the earth's field. Adjusting the BEAM ROTATE resistor varies the current through coil L2001, located around the neck of the CRT, and changes the strength of the magnetic field produced by the coil. When the electron beam enters the magnetic field it is repositioned. You adjust the BEAM ROTATE resistor until the trace line no longer tilts.

Section V. FUNCTIONAL THEORY-DELAYING SWEEP PLUG-IN

74-13A (X-DEFLECTION), NEWER VERSION

3-17. Trigger Circuit (Figs. 3-12, 3-13, and 6-4)

a. Normal and Delaying Triggering

(1) Since the input of the normal and delaying triggering circuit (NDT) is similar to that of delayed armed (DA) trigger circuit, only the NDT circuit will be discussed in detail. Refer to paragraph 3-23 for a description of the X input circuit. The input to trigger amplifier V8201 and V8202 may be selected from one of three sources via the trigger SOURCE switch as follows:

(a) In EXT or EXT/10 position, the signal is obtained from an external source through the EXT TRIG front-panel connector.

(b) In INT position, the signal is derived from the Y plug-in unit.

(c) In LINE position, the signal is tapped from one side of the 6.3-vac heater circuit.

(2) A choice of AC, ACF, or DC coupling is provided by the COUPLING switch. In the AC position, the trigger signal is applied to a high-pass filter consisting of C8203, C8205, and R8207, providing a low-frequency cutoff of 80 cycles. The low-frequency cutoff is raised to 10 KHz in the ACF position, and the high-pass filter now has R8204 shunting R8207. In the DC position, the high-pass filters are disconnected and the triggering signal is applied directly to the trigger amplifier. The RC network, R8206 and C8202, in series with the grid of V8201 or V8202, protects the input circuit from damage due to excessive input voltage. Shunt capacitor C802 across R8206 preserves the high-frequency signal component.

(3) The negative pulse at the output of the trigger amplifier occurs only when there is a positive-going signal at the input. However, it is desirable to start the sweep during either a positive-going or negative-going portion of the excitation signal. To accomplish this, the SLOPE switch is used to select the desired polarity of the triggering signal.

(4) For positive-going signals, connection is made to the grid of V8201, and for negative-going signals, connection is made to the grid of V8202. In each case, the opposite grid is connected to a dc bias source, adjustable by means of LEVEL control R8222. This control is used to select the level of the triggering point for all settings of the SLOPE switch.

(5) The output from V8201 or V8202 is applied to trigger shaper Q8202, which drives trigger coupling transformer T8201. The resulting negative trigger is applied to series coupling diode CR8203 to the base of the delaying sweep gate multivibrator.

(6) TRIG SENS adjustment R8229 sets the tunnel diode trigger at its optimum sensitivity. TRIG BAL adjustment R8234 sets the level of V8201 and V8202 through tunnel diode CR8201, so that no readjustment of the LEVEL control is required when the SLOPE switch is set from plus to minus slopes or vice versa. This adjustment is made when the LEVEL control is set to zero.

b. Automatic Triggering. When the NORM-AUTO-HF RECUR toggle switch is set to AUTO, the trigger circuit is ungrounded and becomes activated. Application of a trigger signal from 10 Hz to 10 MHz switches the sweep immediately to the triggered mode. This technique insures stable synchronization of the desired input signal. The auto trigger multivibrator reverts to its natural mode in about 1 second after the discontinuance of the trigger excitation signal. Consequently, a horizontal reference trace will appear on the screen even in the absence of an input signal.

3-18. Normal Sweep Circuit (Figs. 3-14, 3-15, and 6-4)

a. Delaying Sweep Gate Multivibrator.

(1) The input triggering signal is applied to the base of transistor Q8206, through series-coupling diode CR8203. The dc-coupled bistable multivibrator, Q8206 and Q8207, initiates the formation of the sweep after receiving a negative trigger

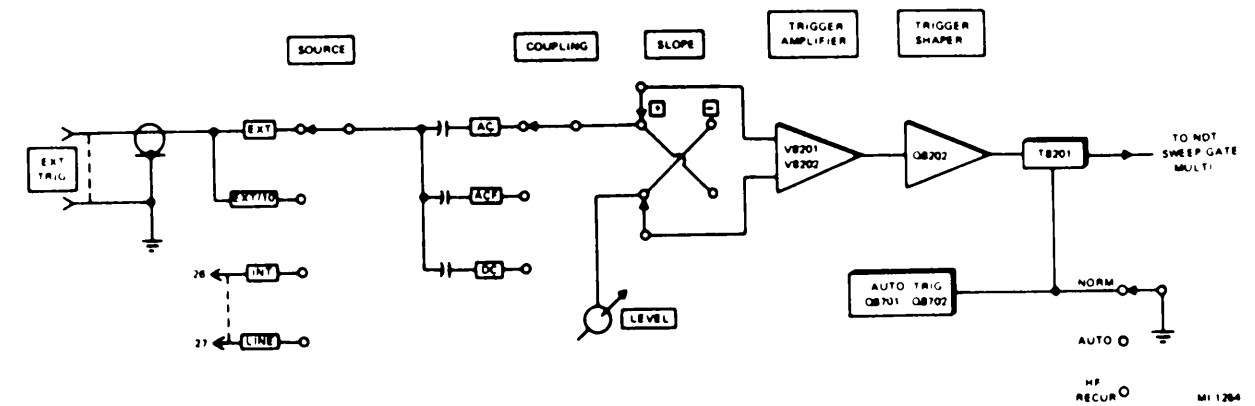

Figure 3-12. NDT trigger circuit, functional block diagram.

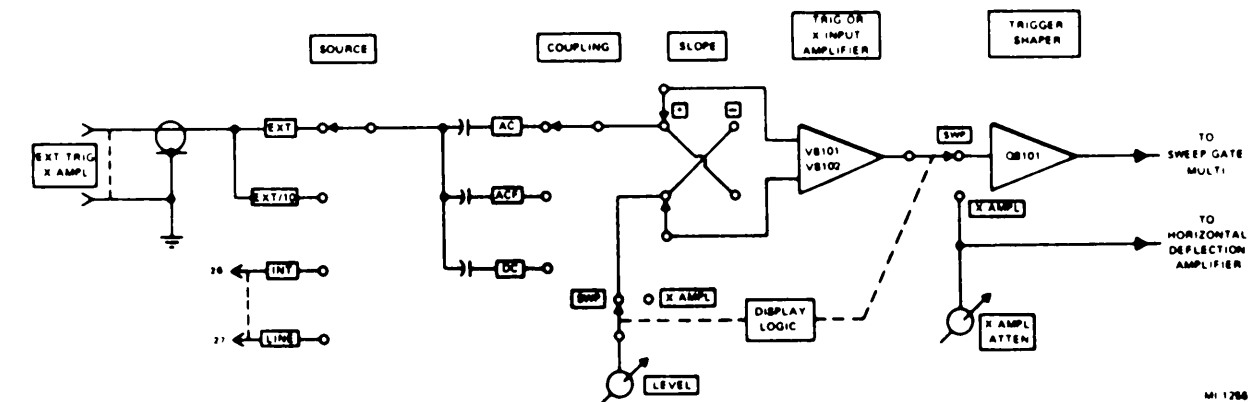

Figure 3-13. DA trigger X input circuit, functional block diagram.

from the shaper circuit. Diode CR8203 and the lockout circuit hold off subsequent triggering signals until after the sweep and retrace are completed. In the quiescent state, Q8206 is conducting and Q8207 is at cutoff. Q8206 forms a positive gate while Q8207 forms a negative gate during the forward sweep interval.

(2) CR8203 serves as a low-capacitance coupling diode which couples the negative trigger from the shaper circuit to the sweep gate multivibrator, which flips and initiates the sweep. CR8203 also serves as a high back-impedance diode to decouple the trigger shaper from the sweep gate multivibrator. After the bistable multivibrator has been triggered, the sweep runs up. When the saw reaches full screen deflection, turn-off diode CR8204 conduct and resets multivibrator Q8206 and Q8207, which then clamps the saw. SWP LENGTH variable resistor R8253 is adjusted for full-screen sweep length display.

b. Saw Generation.

(1) The saw generator is of the Miller "run-up" type. The negative output developed at the collector of Q8207 is applied to the anodes of disconnect diodes CR8205, CR8209, CR8211, and CR8216. The anode voltages of these diodes no longer conduct. This action unlocks the integrator clamp and permits the selected sweep capacitor to charge linearly through the associated resistance network.

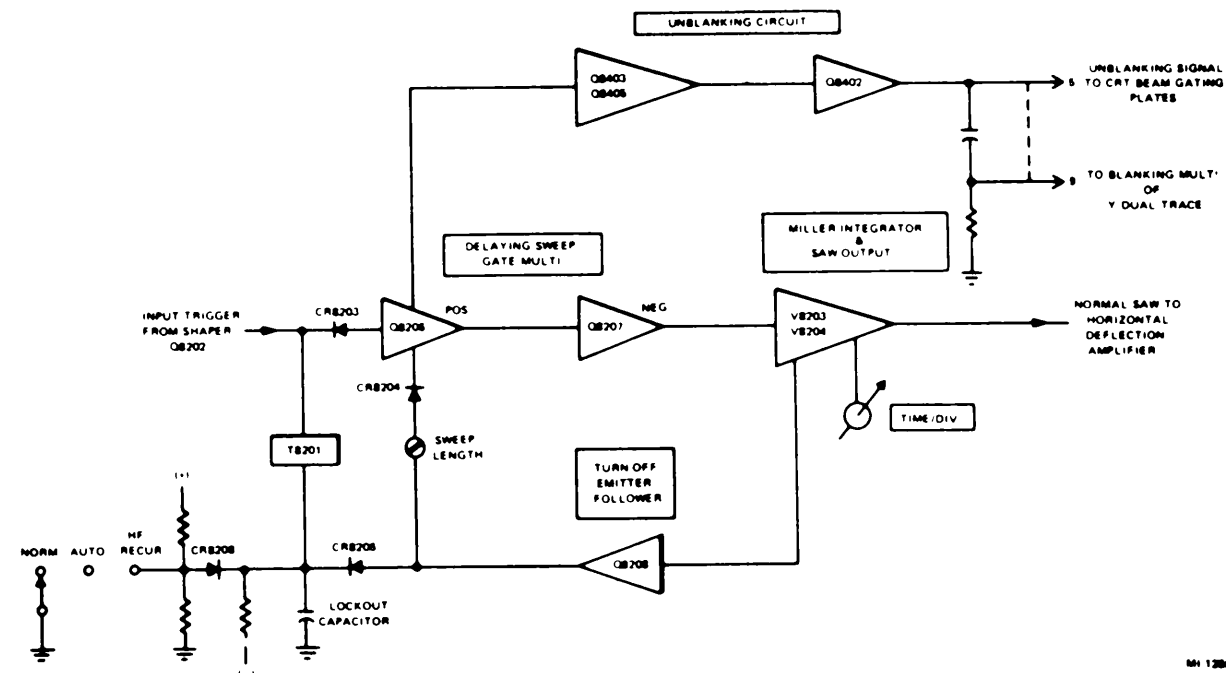

Figure 3-14. Normal sweep mode, functional block diagram.

(2) The grid of the Miller integrator moves negatively when the clamp is unlocked. The plate voltage of V8203 rises positively, carrying the saw cathode-follower (V8204) grid, cathode, and timing capacitor in the same direction. A flow of current is required into the charging capacitor if the voltage across this capacitor is to change. The charging current must flow through the charging resistor. The time required to change the voltage across the charging capacitor determines the sweep time.

(3) The positive voltage swing on the opposite side of the timing capacitor tends to prevent the grid side from swinging negatively. It also increases the voltage to which the timing capacitor is trying to charge. The net result is to straighten out the charging curve (sweep voltage) by maintaining a constant current flow in the capacitor. Since the grid of V8203 remains at a constant potential within a small fraction of a volt, the current through the charging resistor remains constant, and the sweep timing capacitor thus charges at a constant rate. The resulting linear sawtooth waveform is applied to the horizontal deflection system.

c. Sweep Length.

(1) The sweep length, or the total duration of the sweep for any given sweep rate, is determined by the setting of sweep LENGTH adjustment R8263. A portion of the positive sawtooth voltage is fed back to turnoff emitter follower Q8208, and saw turn-off diode CR8204.

(2) If sweep LENGTH R8263 is correctly set, diode CR8204 will conduct when the positive-going excursion of the sawtooth has traveled 10.5 to 11 divisions on the screen. This positive peak signal will then be conducted through diode CR8204 to the base of Q8206. Upon receiving this positive pulse, the sweep gate multivibrator will revert rapidly to its original state with Q8206 conducting, and Q8207 at cutoff. The positive step from the collector of Q8206 returns disconnect diodes CR8216, CR8209, CR8211, and CR8205 to their conducting state, thus discharging the timing capacitors. The Miller circuit now returns to its quiescent level and is ready for the next sweep cycle after the lockout time interval is completed.

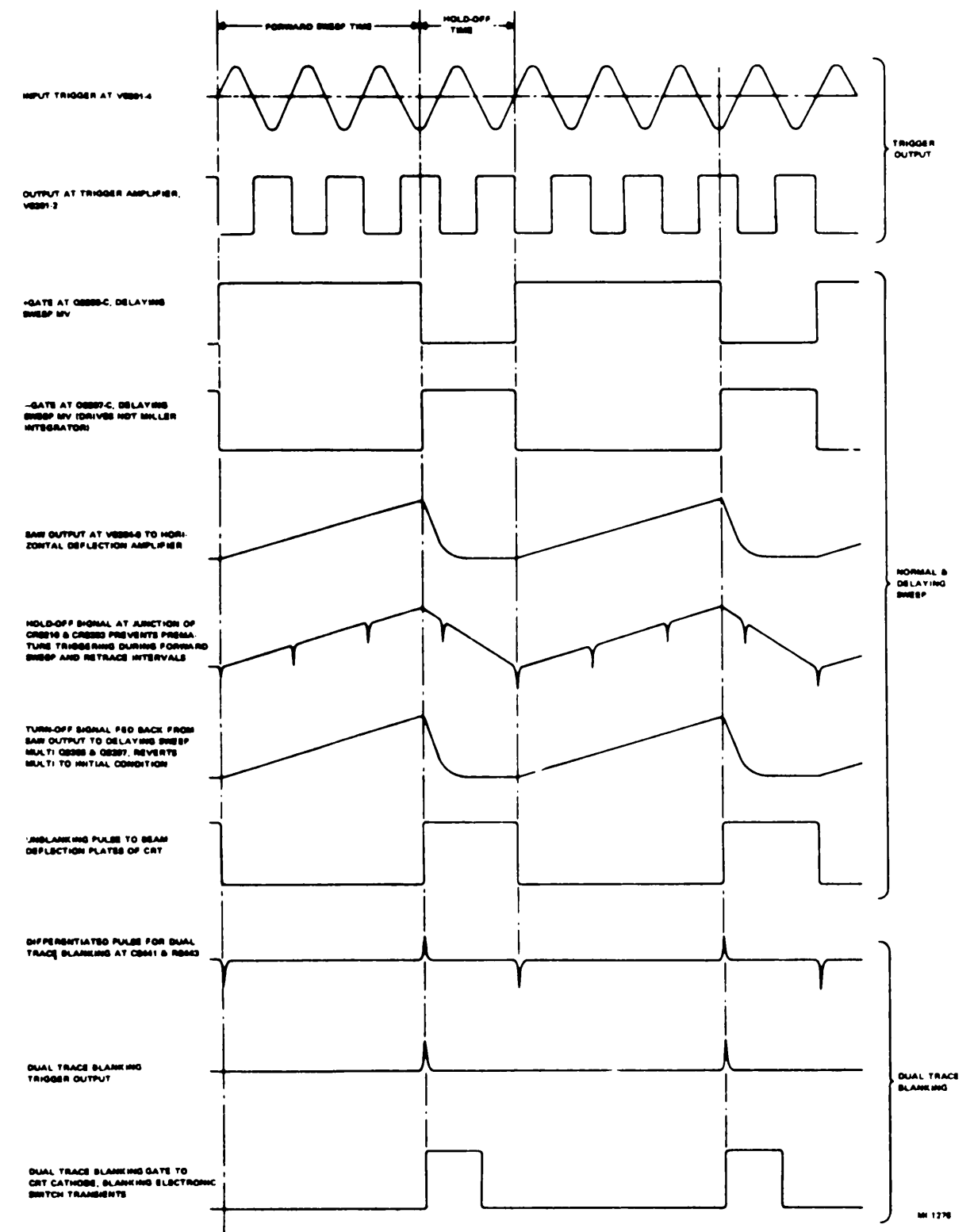

Figure 3-15. Timing diagram for normal sweep display.

d. Lockout Circuit.

(1) The lockout circuit prevents the sweep gate multivibrator from being triggered until the sweep retrace interval has reverted the saw to its quiescent base level. The sweep does not retrace in zero time since the clamping of the Miller integrator timing capacitor is accomplished by a diode switch circuit having a small impedance. The timing circuit discharge (saw retrace) takes longer than the flipping of the sweep gate multivibrator. Consequently, the trigger excitation pulses must be held off to prevent the formation of a new saw during the retrace interval. The sawtooth waveform must be permitted to retrace completely to its quiescent base, which re-establishes the beam at the left-hand side of the CRT screen. This is accomplished by holding the cathode of series triggering diode CR8203 at a suitable positive voltage for a given period after the completion of the sweep.

(2) During the forward sweep interval, a portion of the positive sweep voltage is fed back to the base of turn-off emitter follower Q8208, which charges the lockout capacitor through coupling diode CR8206. When the saw reaches its predetermined full screen length, the sweep gate multivibrator flips and clamps the Miller integrator, which then causes the sweep to retrace. During the return-trace interval, diode CR8206 is cut off and the lockout capacitor is discharged through R8261. The sweep gate multivibrator will not retrigger until the preselected lockout timing capacitor is chosen to give lockout beyond the time that the sweep has returned to rest at its initial starting point.

(3) The duration of the lockout interval is determined by the sweep-charging time constant and the Miller integrator clamp. Consequently, the TIME/DIV switch must also change the lockout circuit hold-off timing capacity. This technique prevents additional triggers from initiating the sweep gate multivibrator until the sweep retrace interval is completed and the saw reverts to its quiescent state at the left-hand side of the screen.

(4) Trigger coupling diode CR8203 prevents triggers from disturbing the sweep gate multivibrator during all of the sweep-forward interval. The lockout circuitry prevents retriggering during the retrace interval.

e. Unblanking.

(1) The cathode-ray tube employed in this oscilloscope has two additional beam-deflecting plates, which cut off the electron beam independently of the control grid. Beam control pulses (trace brightening and retrace blanking pulses) can easily be decoupled since these beam deflection plates are electrically close to ground. In conventional circuits these pulses must be coupled to the control grid, which is operated at high potential. The extra beam deflection plates are controlled by sweep gate multivibrator Q8206 and Q8207.

(2) The positive pulse developed at the collector of Q8206 of the delaying sweep gate multivibrator is applied to the base of unblanking cascode amplifier Q8405 and Q8403. This gate signal is coincident with the sweep forward time and is also available at a front-panel connector labeled + GATE. The resulting negative pulse developed at the collector of Q8403 is applied to the beam deflection plate of the cathode-ray tube through emitter follower Q8402. Therefore the display is visible only during the forward sweep interval and is blanked during the retrace and lockout interval. Transistor Q8401 serves as an emitter follower voltage source for the collector of Q8402, and it also prevents the collector voltage of Q8403 from exceeding 125 volts.

(3) A portion of the negative pulse from unblanking emitter follower Q8402 is applied to differentiating network C8441 and R8443. The output from this network provides the proper trigger to the blanking multivibrator of the dual trace plug-in.

(4) These delaying sweep time base plug-in units may be used in the X or Y cavity of the main frame. Only the X cavity permits retrace beam blanking signals to be coupled to the cathode-ray tube. Therefore, sweep operation in the vertical direction will show the sweep retrace.

3-19. Triggered-Strobe Mode (Figs. 3-16, 3-17, and 6-4)

a. When the DISPLAY LOGIC switch is set to TRIG STROBE, the delay pick-off, the delayed sweep, and strobe circuits are activated. In the "triggered" mode, the delaying sweep receives the external trigger signal while the delayed sweep receives its trigger signal later from the delaying sweep. The triggering signal for the delayed sweep in this mode is derived from the delaying sweep at the exact instant this sweep reaches a level determined by the adjustment of the delay pick-off circuit. This mode from now on will be referred to as the delayed-triggered mode. The normal and delaying sweep circuit functions as previously described. Major differences between the triggered strobe and the normal mode circuits may be seen by comparison of the block diagram.

b. Referring to figure 3-16, the saw from the delaying sweep circuit is applied to the horizontal deflection amplifier and to the input of delay pick-off comparator circuit Q8601 and Q8602. This circuit is a differential amplifier which compares the voltage level of the input delaying sweep against a fixed voltage obtained from the DELAY VERNIER control. When the voltage level of the delaying sawtooth waveform reaches a certain level, as determined by the setting of the DELAY VERNIER control, the output of the comparator circuit is applied to delayed trigger amplifier Q8604, which drives coupling transformer T8601. The negative pulse from the secondary of this transformer is through series-coupling diode CR8105, to trigger delayed sweep gate multivibrator Q8106 and Q8107.

c. The positive gate developed at the collector of Q8106 is coincident with the delayed TIME/DIV control setting and is

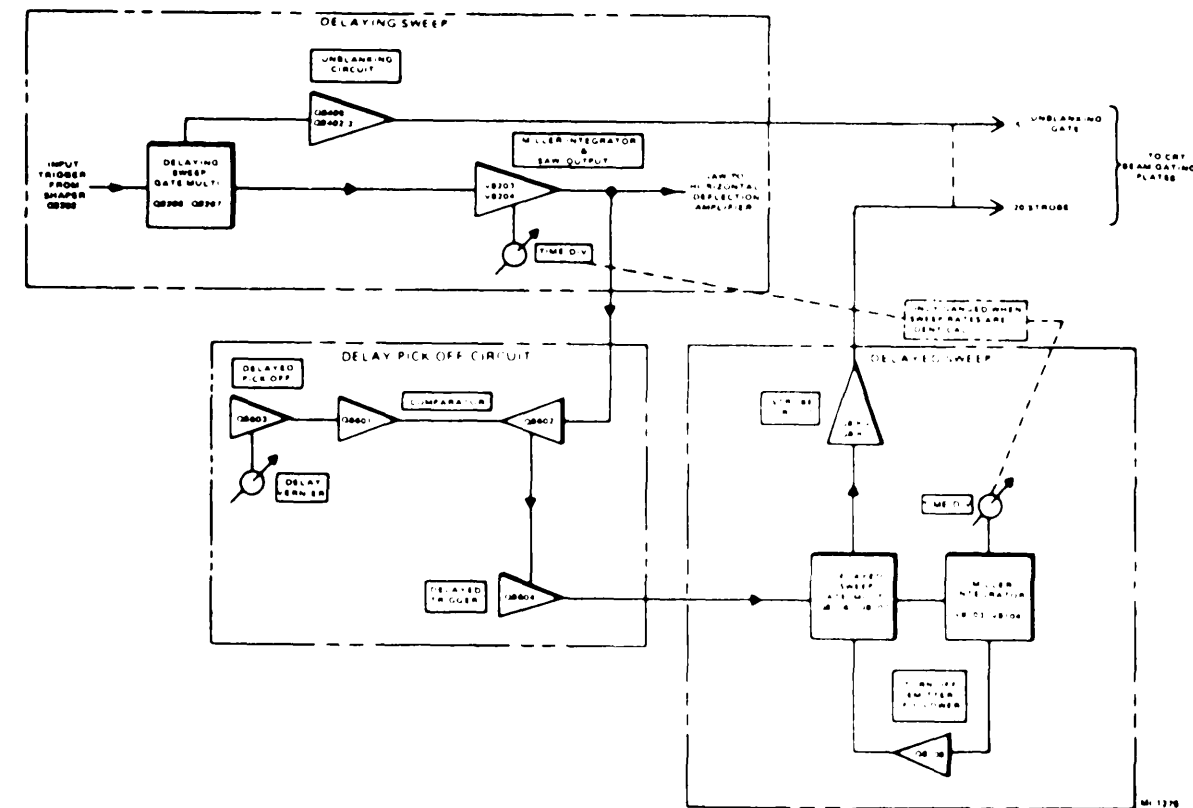

Figure 3-16. Triggered strobe mode, functional block diagram.

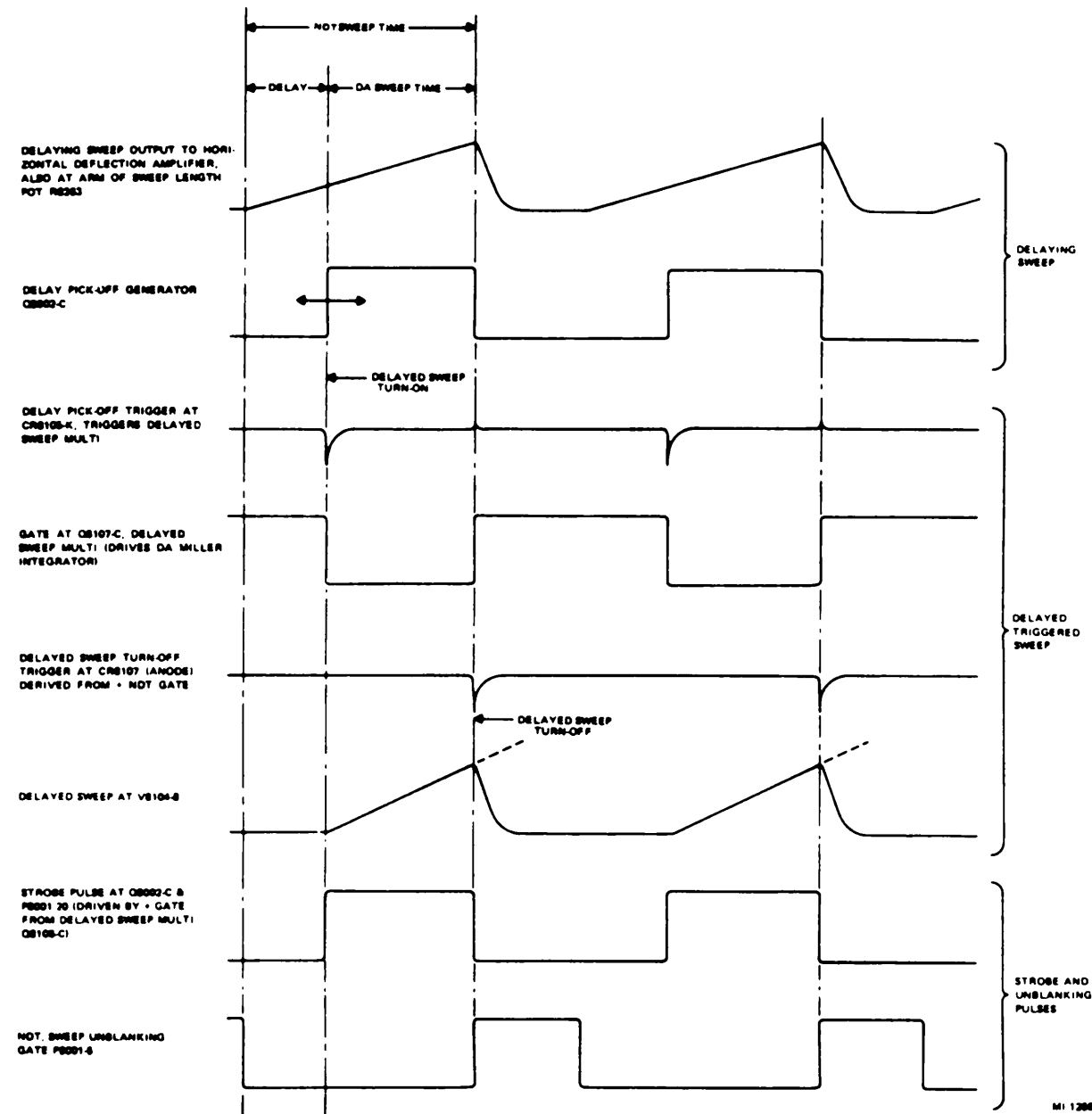

Figure 3-17. Simplified timing diagram, triggered-strobe display.

applied to strobe circuit Q8001 and Q8002. The positive strobe signal is applied to one of the beam-gating electrodes of the CRT. The delaying sweep unblanking gate is applied to the other beam-gating electrode.

d. The cathode-ray beam is kept turned off when a sweep is not moving the beam across the screen. When a sweep is in progress, the beam is turned on by an unblanking signal that lasts long as the sweep and then turns the beam back off after the sweep is completed. When both the delaying and delayed sweeps are running, each produces its own unblanking signal.

The delayed sweep unblanking pulse (strobe) makes a brighter trace than the delaying sweep pulse.

e. The delaying sweep is automatically turned off when the delayed sweep has terminated. This action is developed as follows: the positive gate produced at the collector of delayed sweep multivibrator Q8106 is applied to a differentiating network consisting of R8247 and C8216. Series-coupling diode CR8202 is biased to permit only the trailing edge of the delayed sweep gate to trigger the delaying sweep multivibrator and subsequently terminating the NDT sweep. This prevents brightening of the sweep retrace in the STROBE position.

3-20. Delayed-Triggered Mode (Figs. 3-18, 3-19, and 6-4)

When the DISPLAY LOGIC switch is set to TRIG DLY'D, the delayed sweep and not the delaying sweep is applied to the horizontal deflection amplifier. The brightened sector of the display in the STROBE position will not be expanded to full screen in the DLY'D position. The delayed-triggered sweep circuit is similar in operation to the triggered-strobe mode described earlier, except that the strobe circuit is not activated. Automatic provision is made for shut-off of the delaying sweep when the delayed sweep terminates. This technique permits maximum duty cycle performance in the delayed mode.

3-21. Armed-Strobe Mode (Figs. 3-20, 3-21, and 6-4)

a. When the DISPLAY LOGIC switch is set to ARM STROBE, the delay pick-off circuit, the arming multivibrator, the delayed sweep, and strobe circuits are activated. In the "armed" mode, the delayed sweep is triggered by a selected external-triggering signal. All triggering signals are blocked by the armed lockout diode until a signal from the delay pick-off circuit triggers the arming multivibrator. This action unlocks the diode and opens the trigger circuit to the delayed sweep, making it

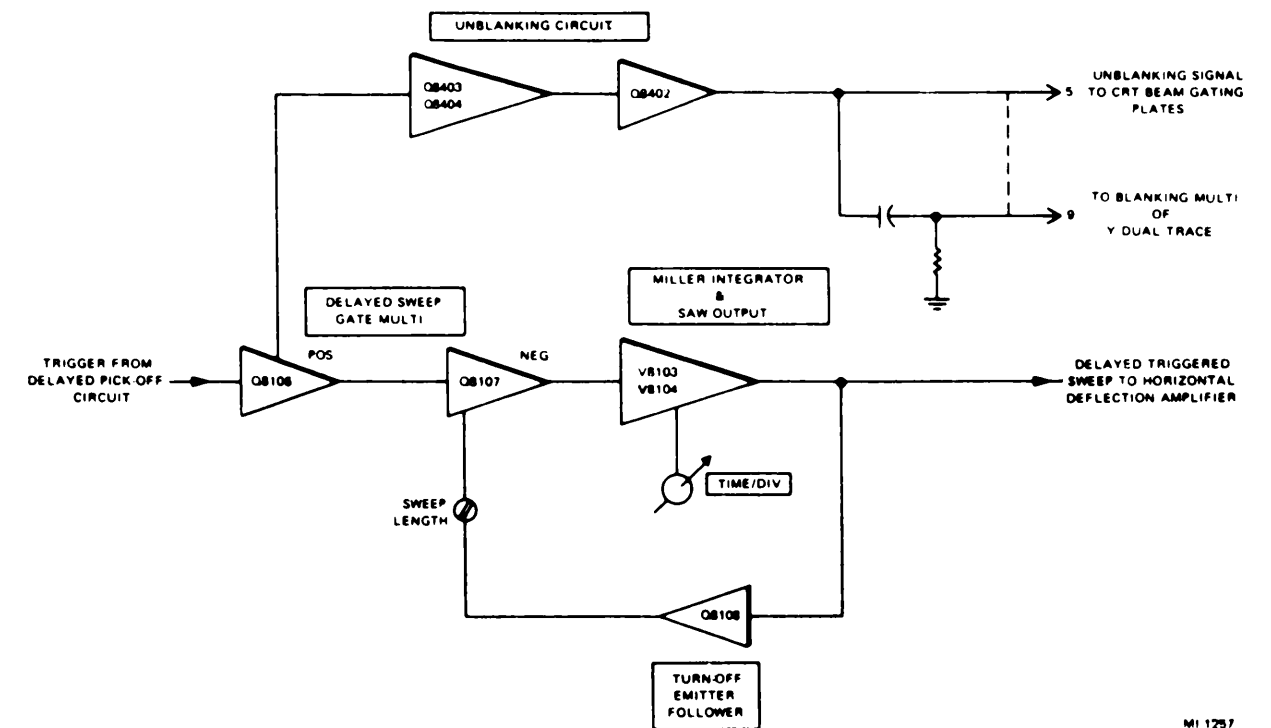

Figure 3-18. Delayed-triggered mode, functional block diagram.

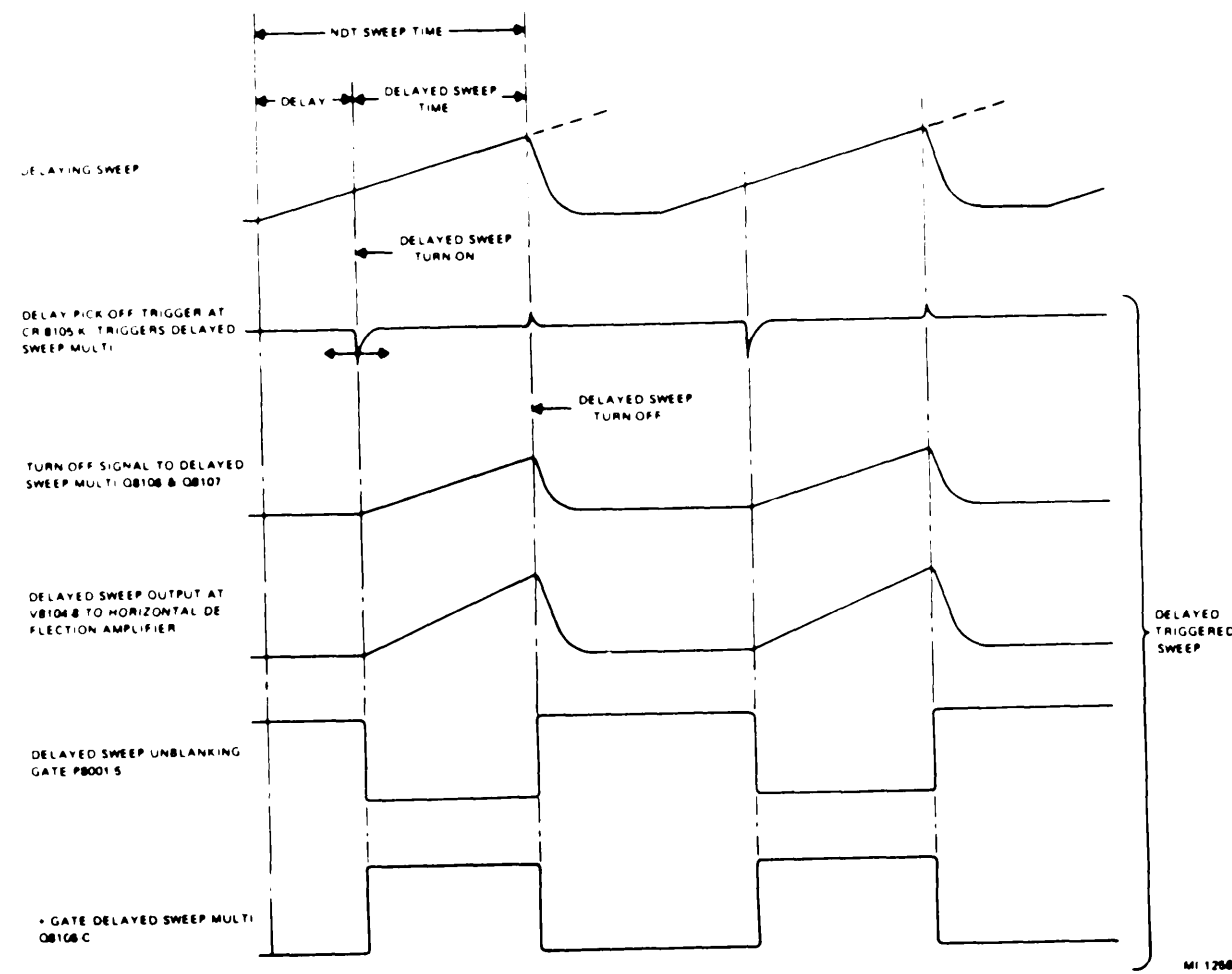

Figure 3-19. Simplified timing diagram, delayed-triggered display.

possible for the next appropriate triggering signal to initiate the delayed sweep. In this mode of operation, the delayed sweep does not start precisely at the delay time indicated by the DELAY VERNIER and NDT TIME/DIV control settings, but instead is initiated by the next suitable triggering following the indicated delay interval. This mode from now on will be referred to as the delayed-armed mode of sweep operation. The armed lockout diode, CR8102, is not forward-biased by the voltage applied to it from the collector of Q8103, thus opening the triggering circuit to delayed sweep gate generator Q8106 and Q8107.

b. The SWP READY lamp on the front panel goes on when the delay time has elapsed and indicates that the delayed sweep circuit is ready to be triggered. When the delayed sweep is triggered, the SWP READY lamp then goes out. If the delayed-armed sweep is triggered immediately at the completion of the delay time, the SWP READY lamp may not appear to go on.

c. The next suitable trigger from the DA trigger is applied to the delayed sweep multivibrator, which immediately changes states (it flips). Q8106 forms a positive gate while Q8107 forms a negative gate during the "delayed" sweep forward interval. In the quiescent state of the armed multivibrator, Q8103 is at cutoff and Q8104 is conducting. The armed lockout diode, CR8102, is back-biased by the voltage applied to it from the collector of Q8103. This action locks out incoming triggering

signals to the delayed sweep gate multivibrator, thereby inactivating the delayed sweep.

d. The arming signal from the delayed pick-off circuit is coupled from transformer T8601, through diode CR8104, to the base of transistor Q8104. The bistable armed multivibrator changes states: Q8104 is at cutoff and Q8103 is conducting. The leading edge of the negative gate at the collector of Q8107 is differentiated by C8118 and R8143 and applied to the base of transistor Q8103 through diode CR8103. This disarming trigger reverts the armed multivibrator to its initial condition. After the bistable delayed sweep gate multivibrator has been triggered, it will revert to its original state as determined by the setting of SWP LENGTH adjustment R8159. The delayed sweep will remain inactivated until the armed multivibrator is rearmed by a signal from the delayed pick-off circuit.

e. The development of the strobe and unblanking pulses are identical to that described for the triggered-delayed mode. Automatic provision is made for turning off the NDT sweep when the DA sweep has terminated. This prevents brightening of the sweep retrace in the strobe position.

3-22. Delayed-Armed Mode (Figs. 3-22, 3-23, and 6-4)

When the DISPLAY LOGIC switch is set to ARM DLY'D, the delayed sweep is applied to horizontal deflection plates. The delayed-armed sweep circuit is similar in operation to the armed-strobe mode described earlier, except that the strobe circuit is not inactivated.

3-23. Horizontal Deflection Circuit (Figs. 3-24 and 6-4)

a. When the DISPLAY LOGIC switch is set to X AMP, the EXT TRIG input connector of the delayed sweep becomes the X amplifier input. Simultaneously, the delayed sweep LEVEL control becomes the variable X AMPLIFIER ATTENUATOR control. The PULL EXT/10 setting provides 10:1 attenuation of the X input signal. Thus external signals may be applied to the X AMP front-panel BNC connector. These signals are coupled to X input amplifier V8101 and V8102. The output of this amplifier is coupled to the horizontal deflection circuit via the X AMP setting of the DISPLAY LOGIC switch (fig. 3-13). The output from V8102 is applied through a voltage divider network to the base of emitter follower Q8301 via the DISPLAY LOGIC switch.

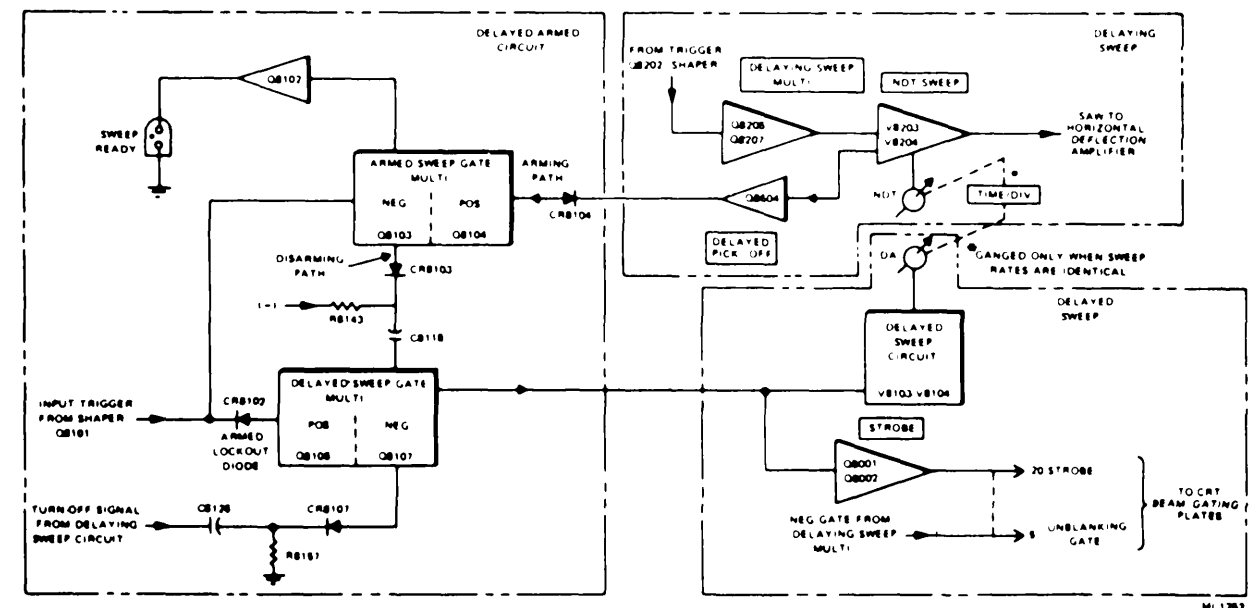

Figure 3-20. Armed strobe mode, functional block diagram.

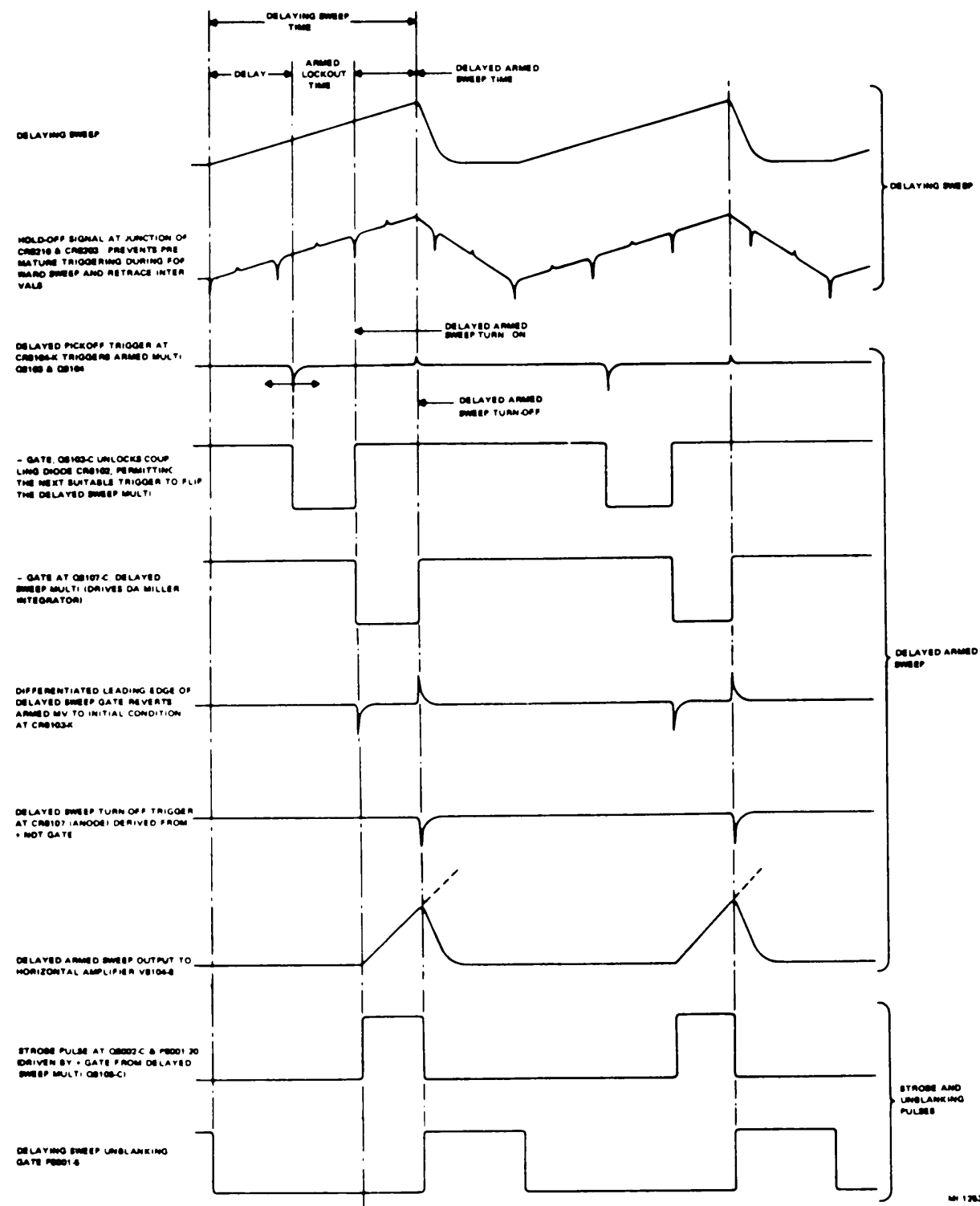

Figure 3-21. Simplified timing diagram, delayed-armed strobe display.

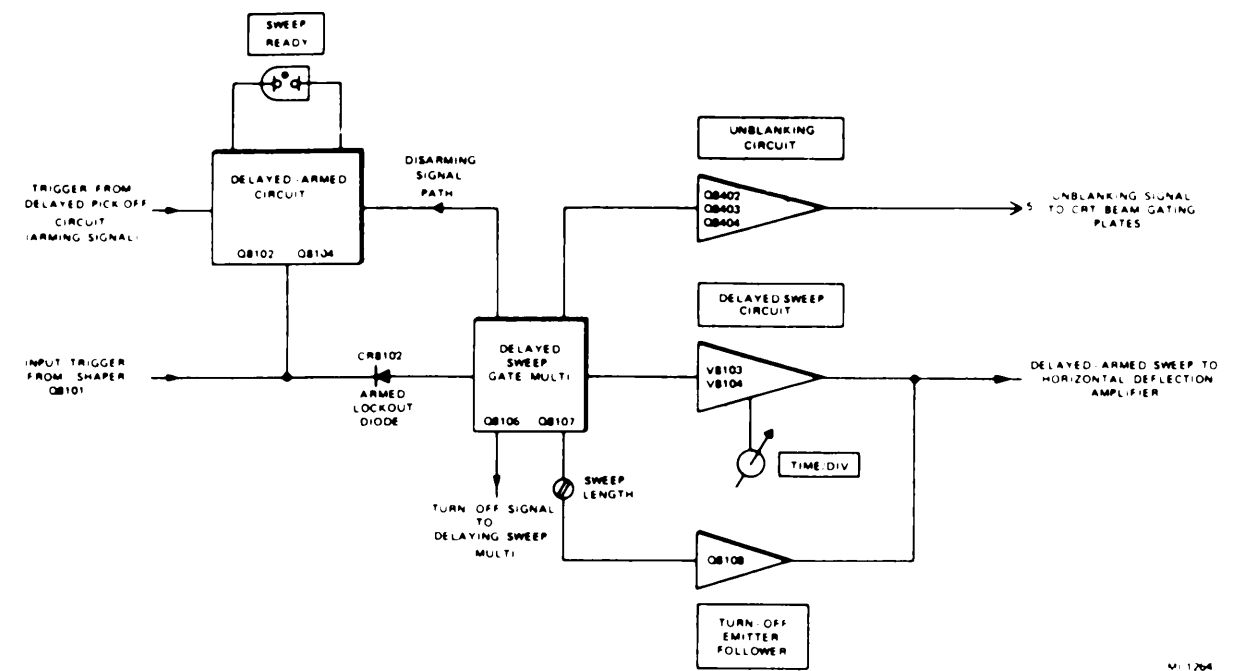

Figure 3-22. Delayed-armed mode, functional block diagram.

b. The POSITION control supplies a manually-adjustable dc voltage to the base of Q8301 for positioning the display on the screen. The output from the emitter of Q8301 is applied directly to common emitter amplifier Q8302 and Q8303, which converts the single-end input to a push-pull output. The signal progresses through emitter follower Q8305 and Q8306, and is then applied to output amplifier Q8307 to Q8311. In this output amplifier stage, the signal develops the necessary power for driving the horizontal deflection plates. Ten-times magnification of the sweep is accomplished by reducing the common emitter amplifier feedback of Q8302 and Q8303, by a factor of 10 when the X10 control is pulled out. Consequently, the sweep rate observed on the screen of the cathode-ray tube is effectively magnified ten times. The X10 REGISTRATION potentiometer R8311 is provided to adjust the voltage level at the base of Q8303 so that the center of the trace is not deposited from CRT screen center when the PULL X10 switch is activated. For the Type 765 Series, a PATTERN POSITIONING control is mounted on the front panel of the Main Frame, and it is electrically coupled to the POSITION control of both the X and Y Plug-ins. This feature permits positioning the entire display in the horizontal and vertical directions on the screen via use of the single joystick control.

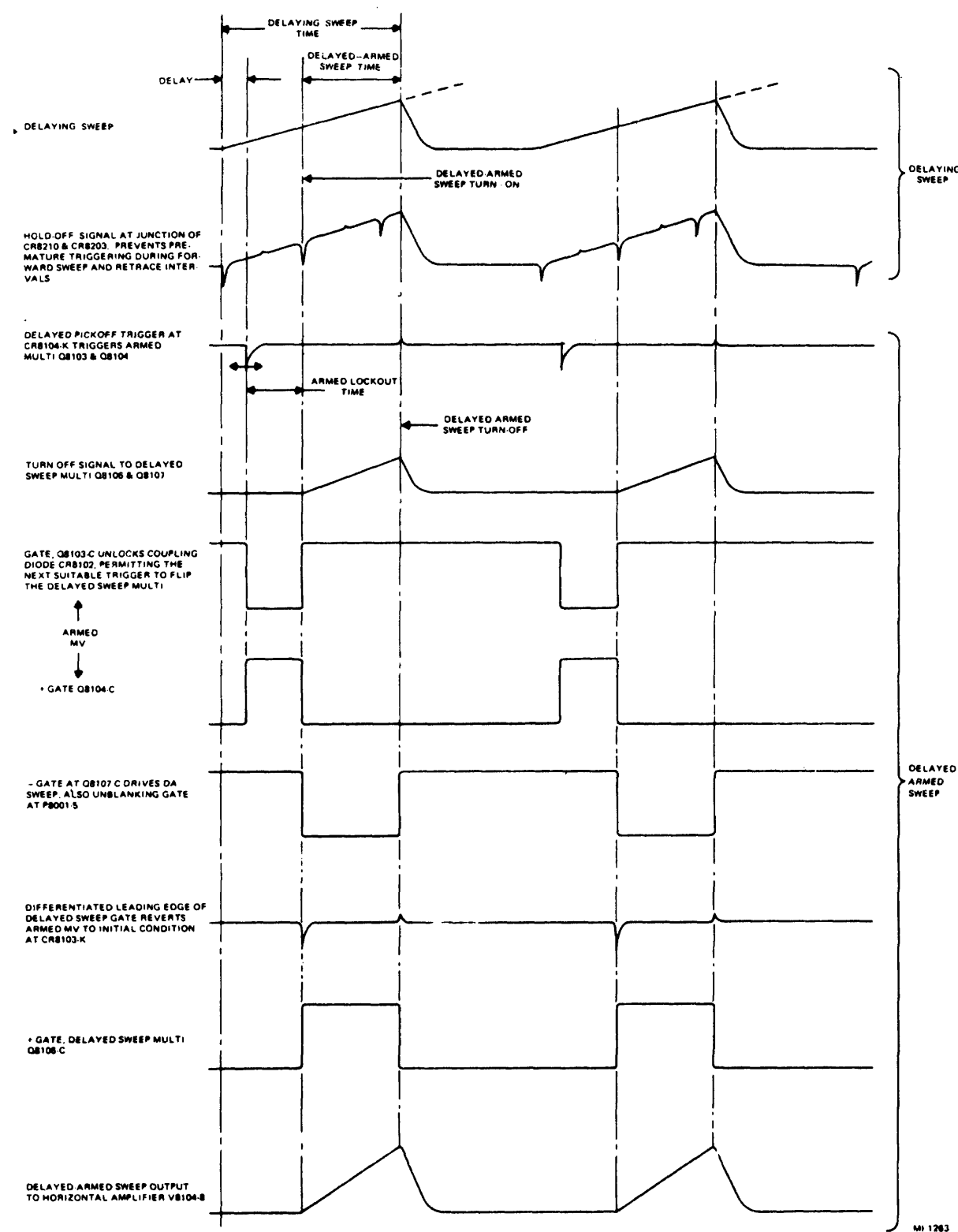

Figure 3-23. Simplified timing diagram for delayed-armed display.

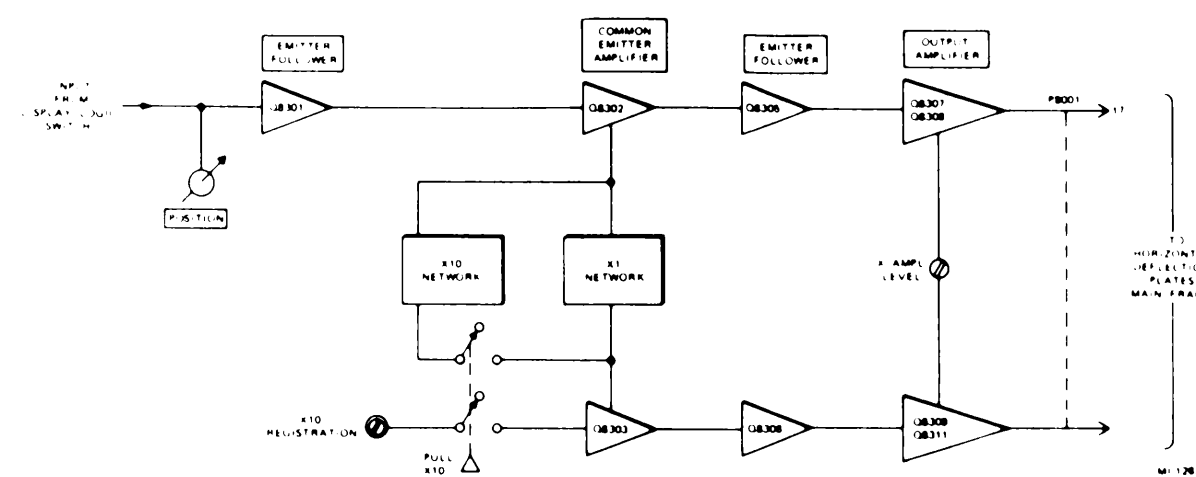

Figure 3-24. Horizontal deflection amplifier, functional block diagram.

CHAPTER 4
BLOCK DIAGRAMS AND FUNCTIONAL SCHEMATICS

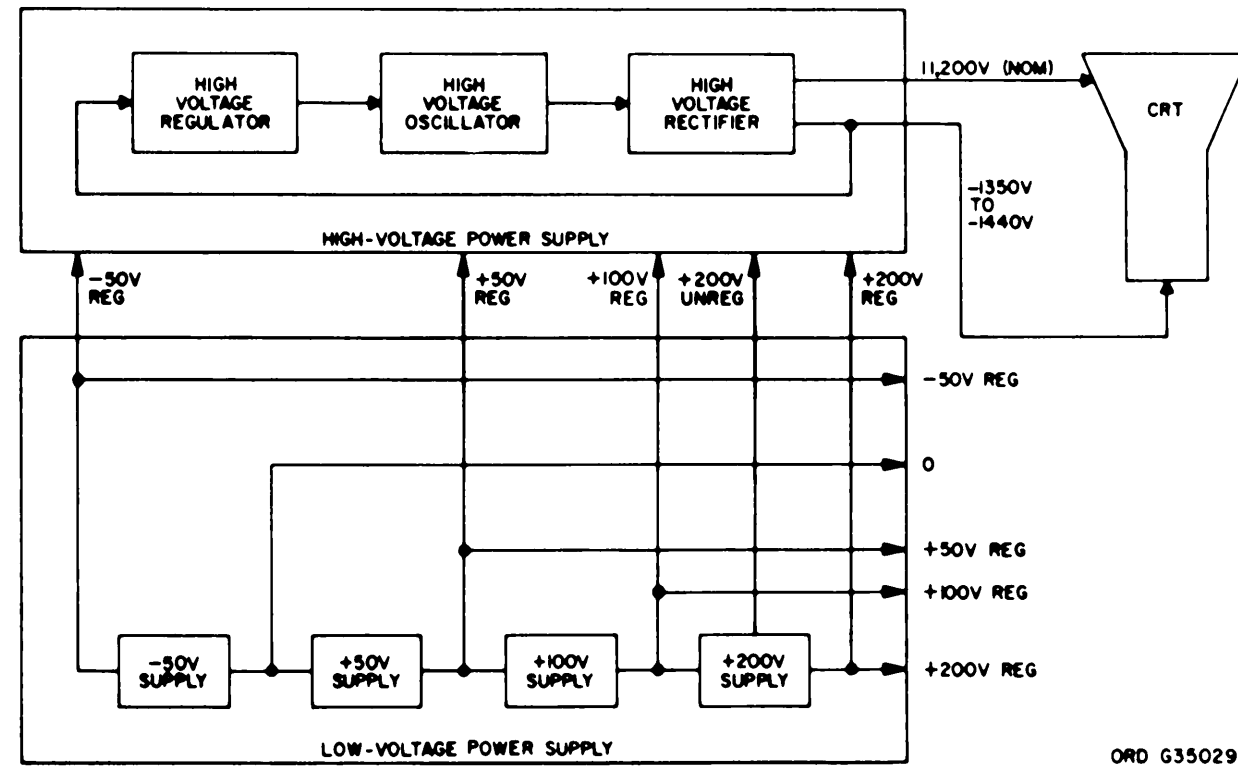

Figure 4-1. Power supply, block diagram.

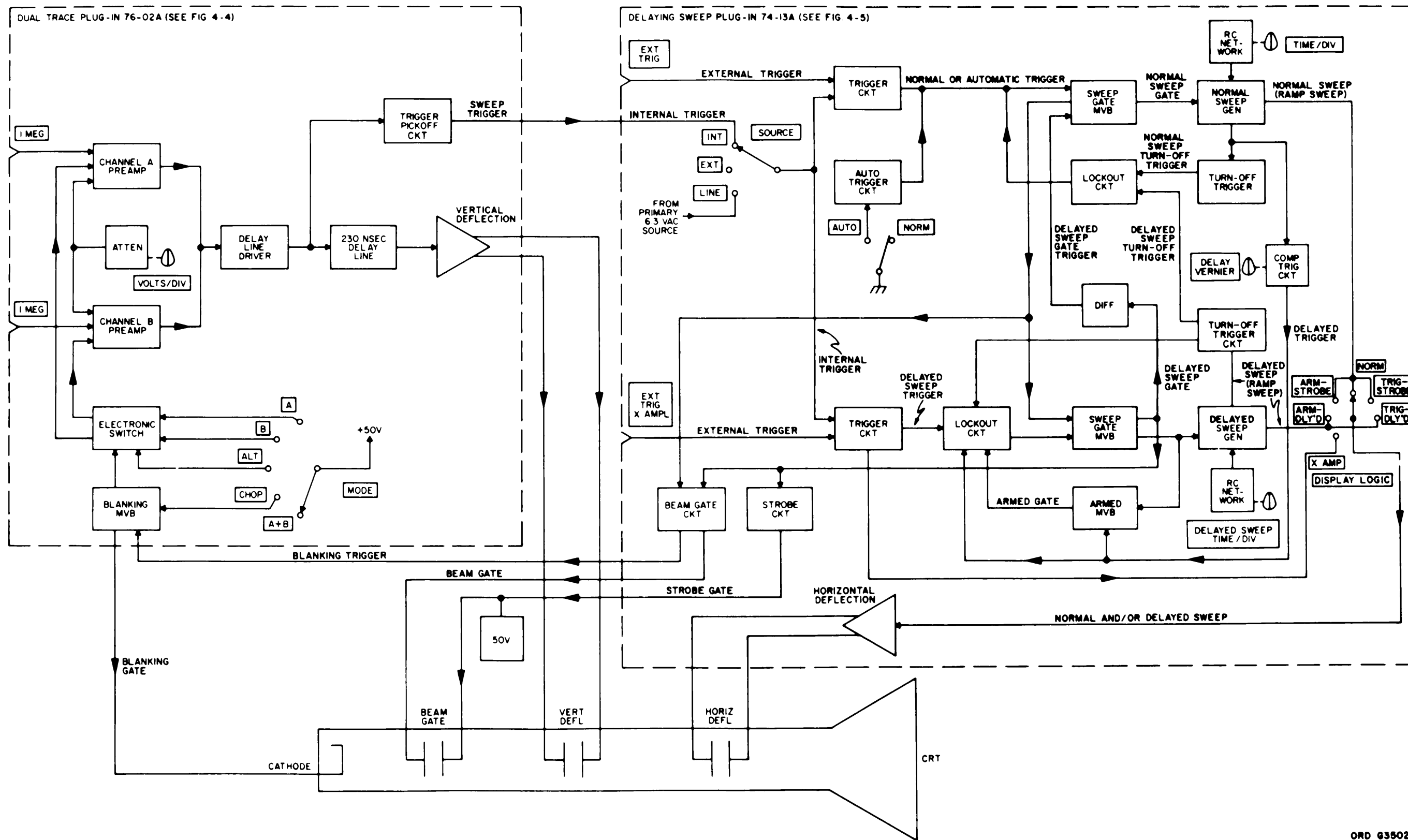

Figure 4-2. Oscilloscope, block diagram.

ORD 6350296

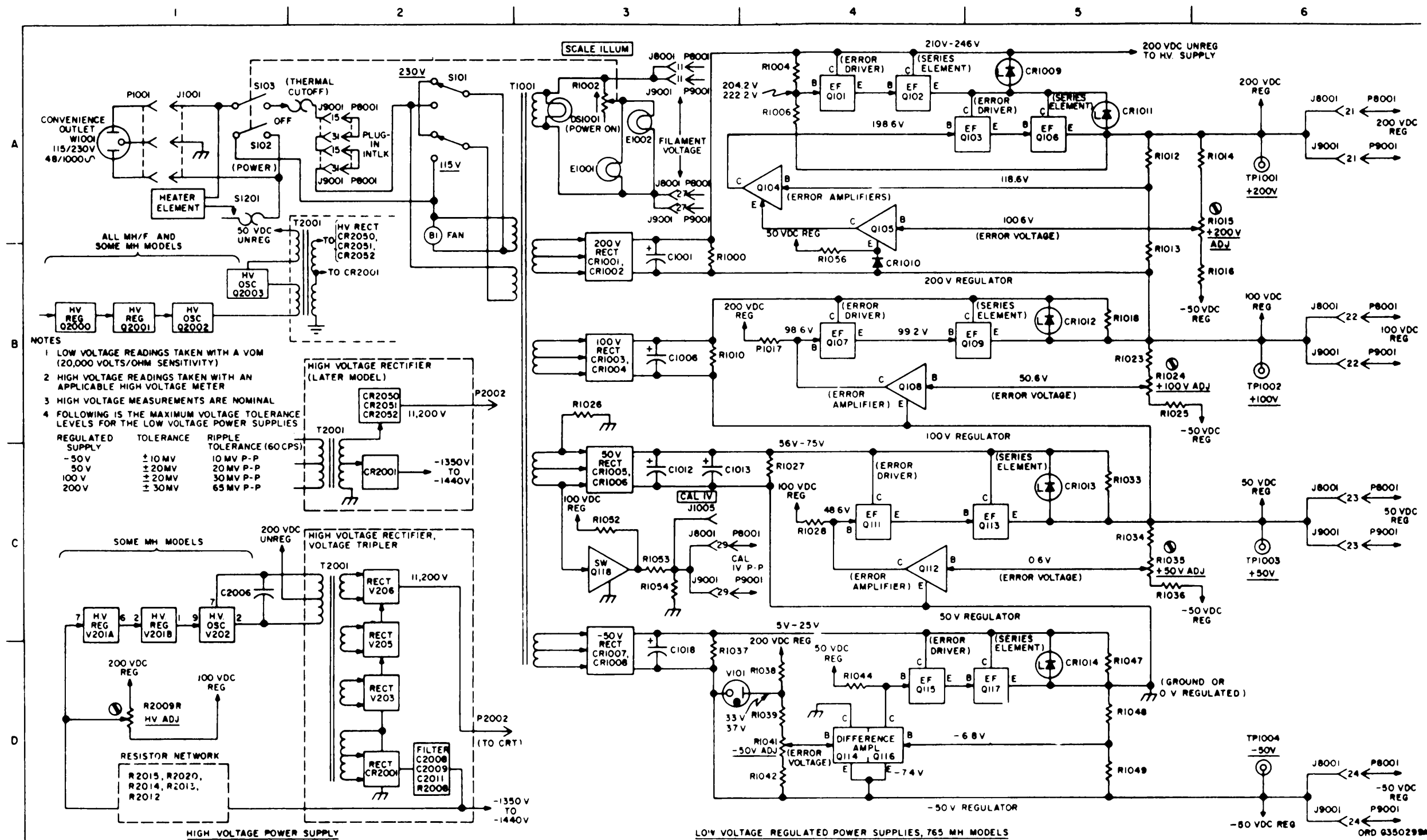

Figure 4-3. Power supply, functional schematic.

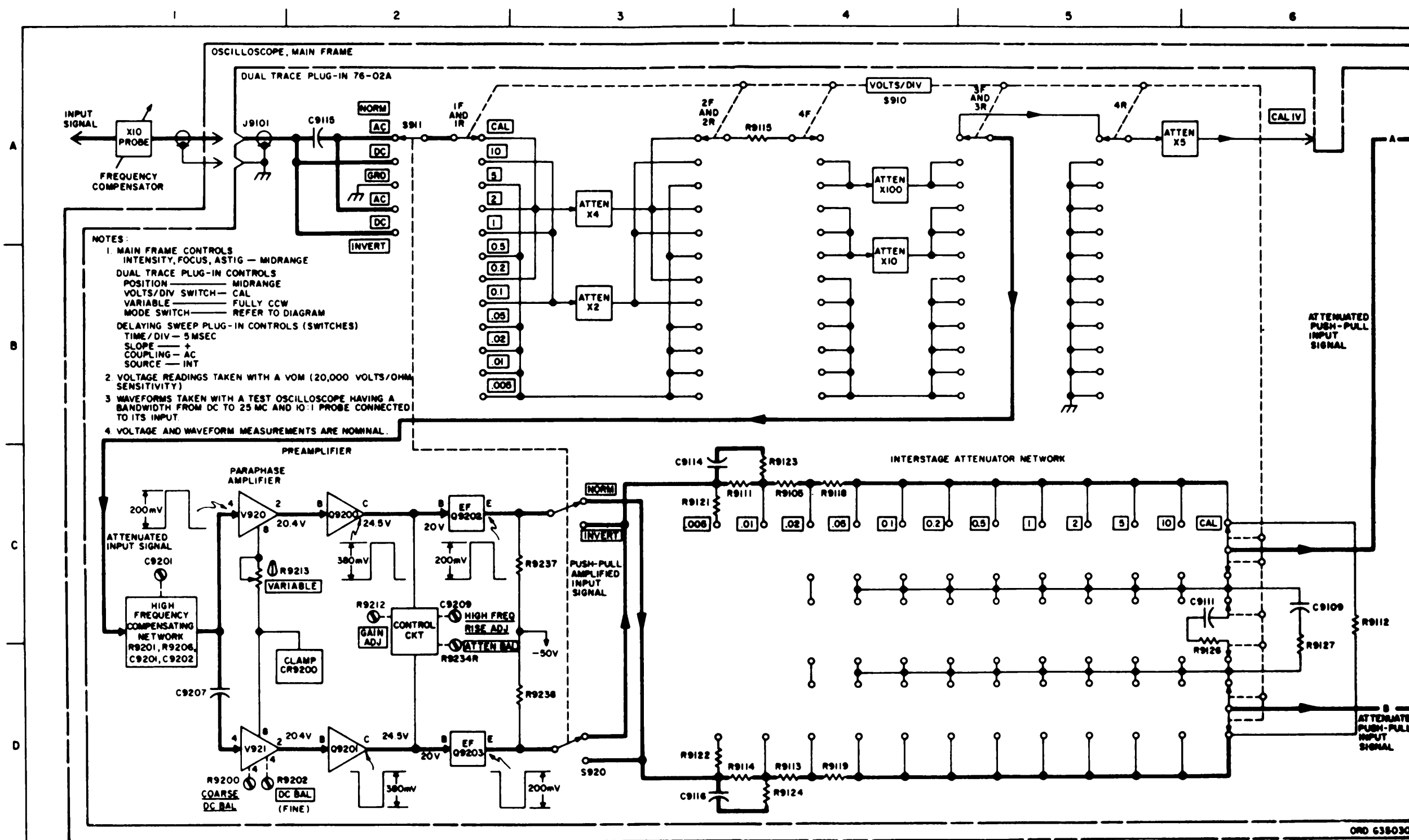

Figure 4-4. Dual trace plug-in (type 76-02A), functional schematic (sheet 1 of 2).

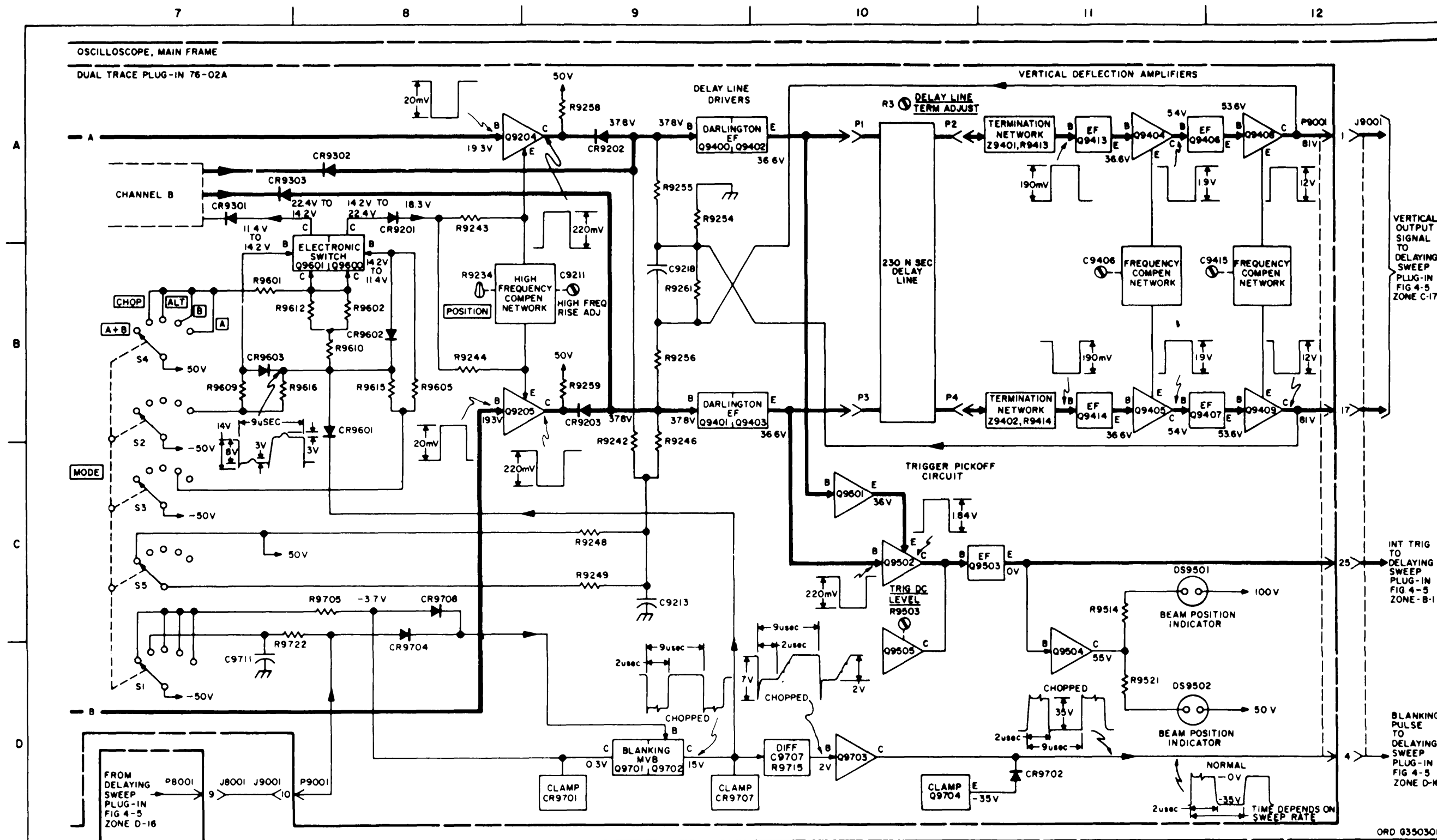

Figure 4-4. Dual trace plug-in (type 76-02-A), functional schematic (sheet 2 of 2).

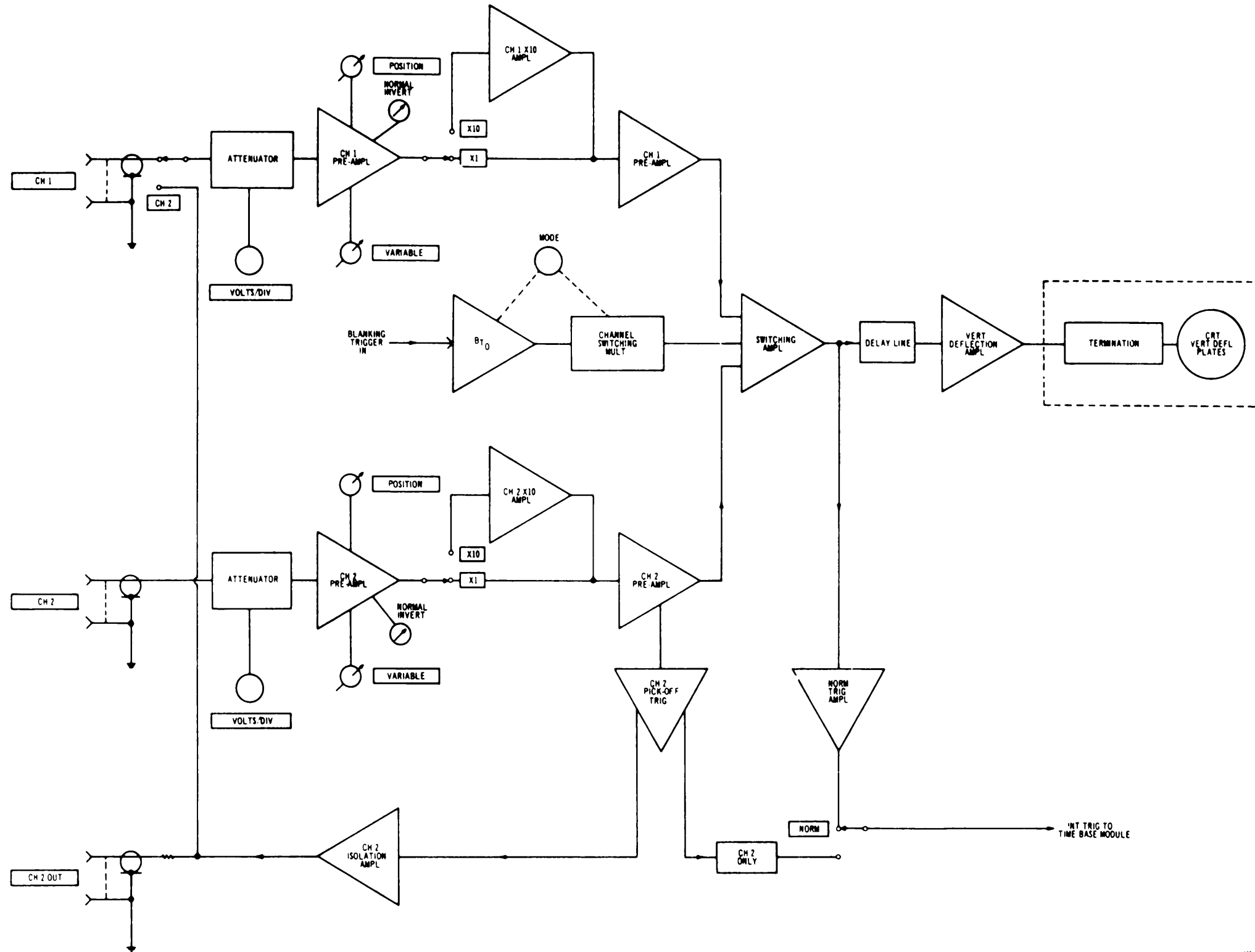

Figure 4-4.1. Dual trace plug-in (type 79-0A), functional schematic (sheet 1 of 4)

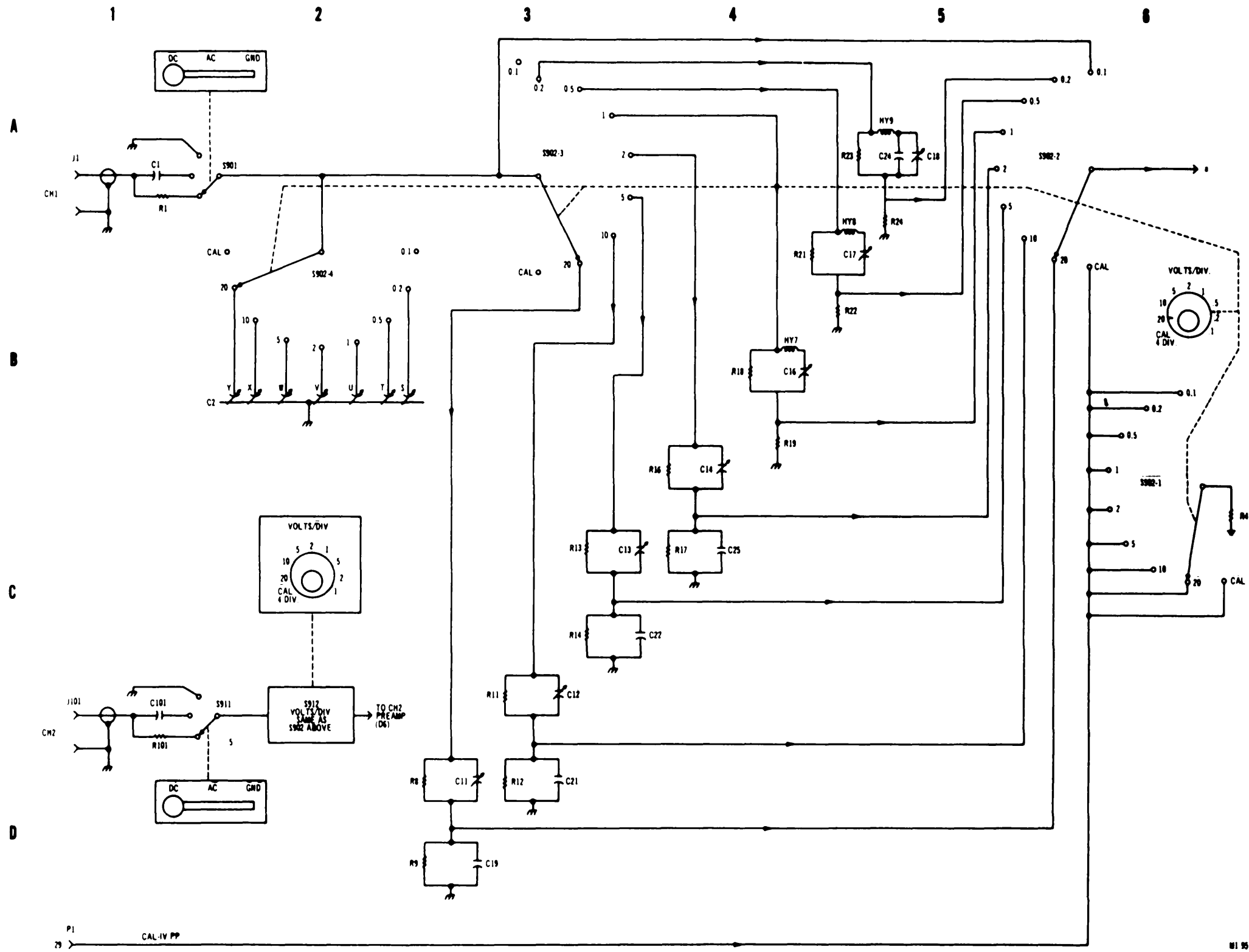

Figure 4-4.1. Dual trace plug-in (type 79-02A), functional schematic (sheet 2 of 4)

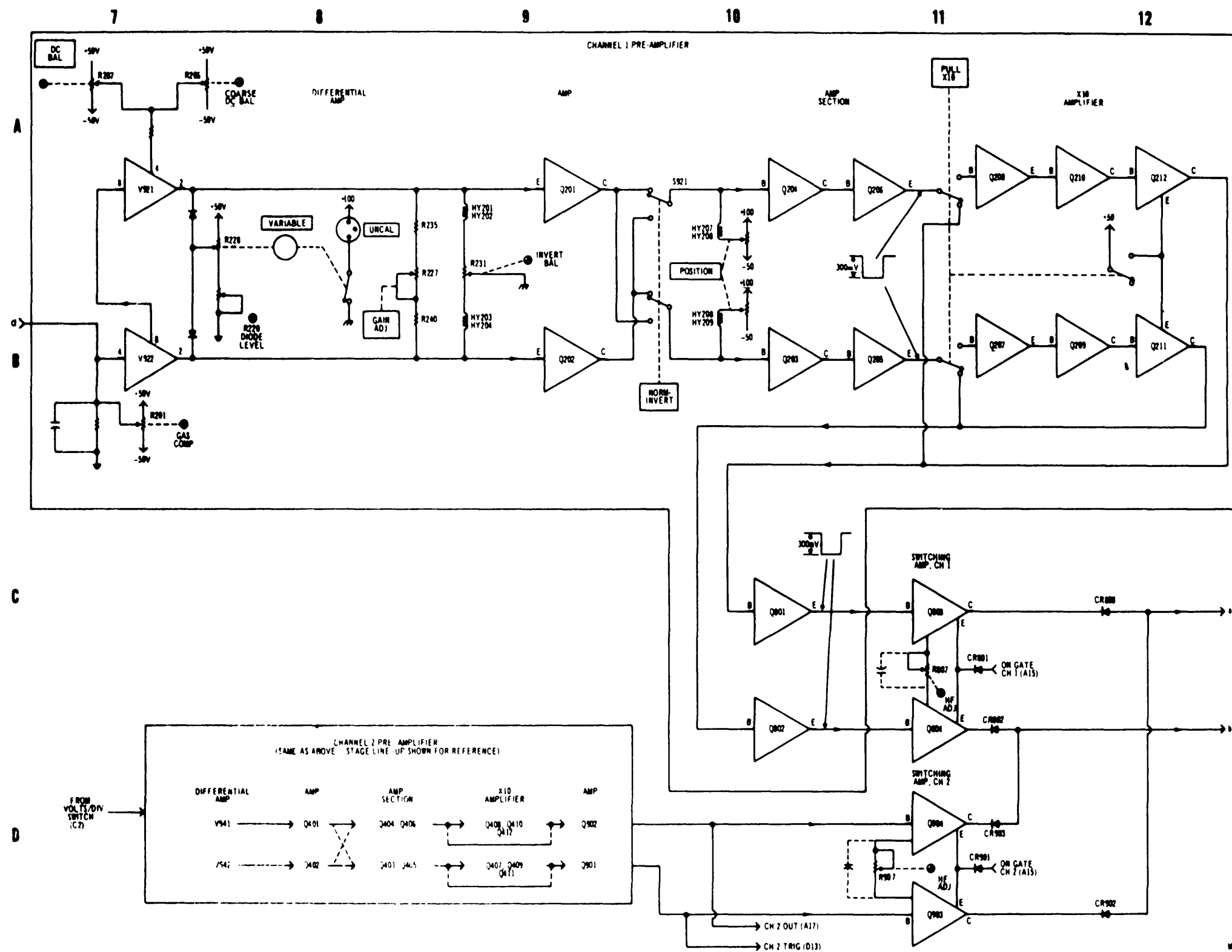

Figure 4-4.1. Dual trace plug in (type 79-02A), functional schematic (sheet 3 of 4)

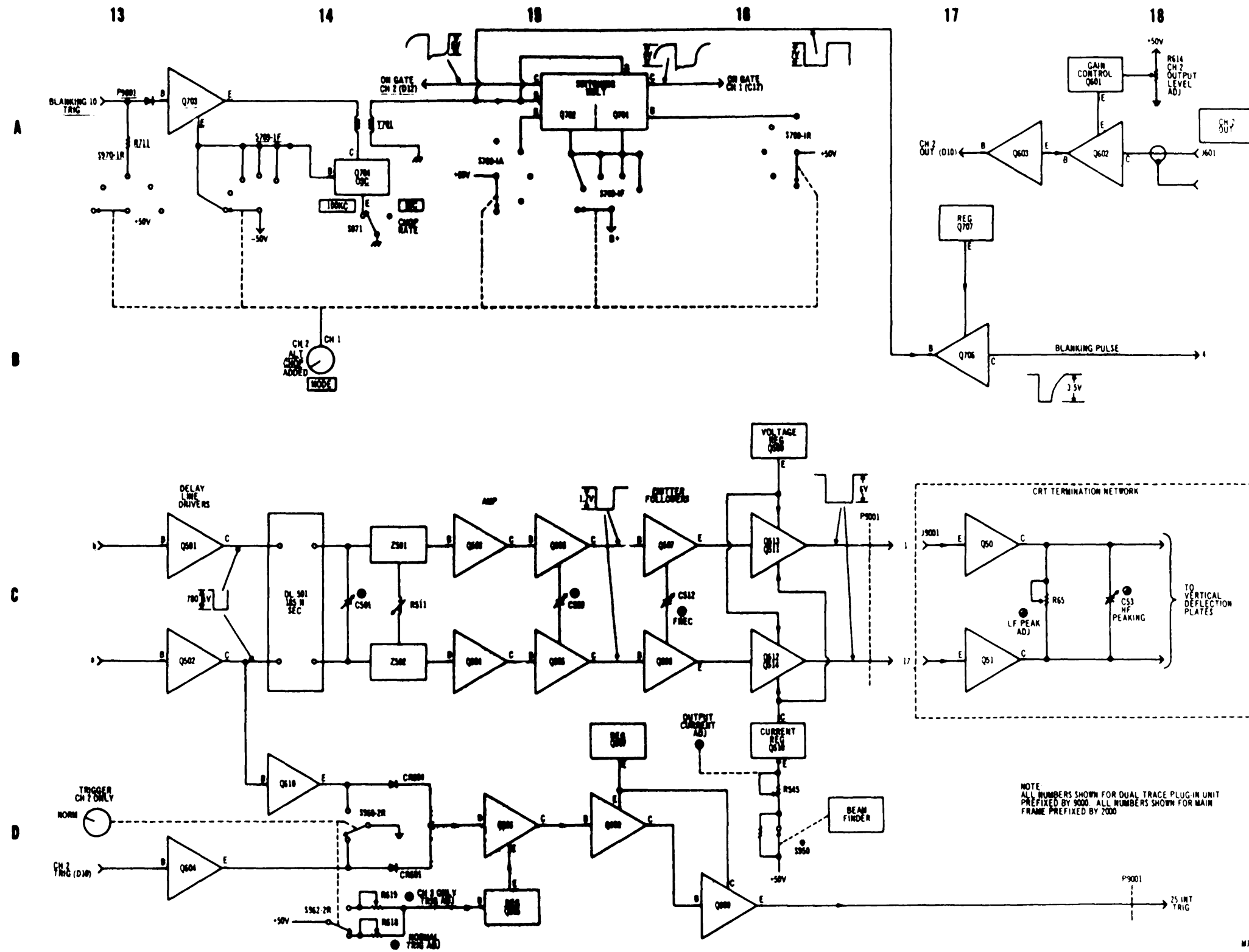

Figure 4-4.1. Dual trace plug-in (type 79-02A), functional schematic (sheet 4 of 4)

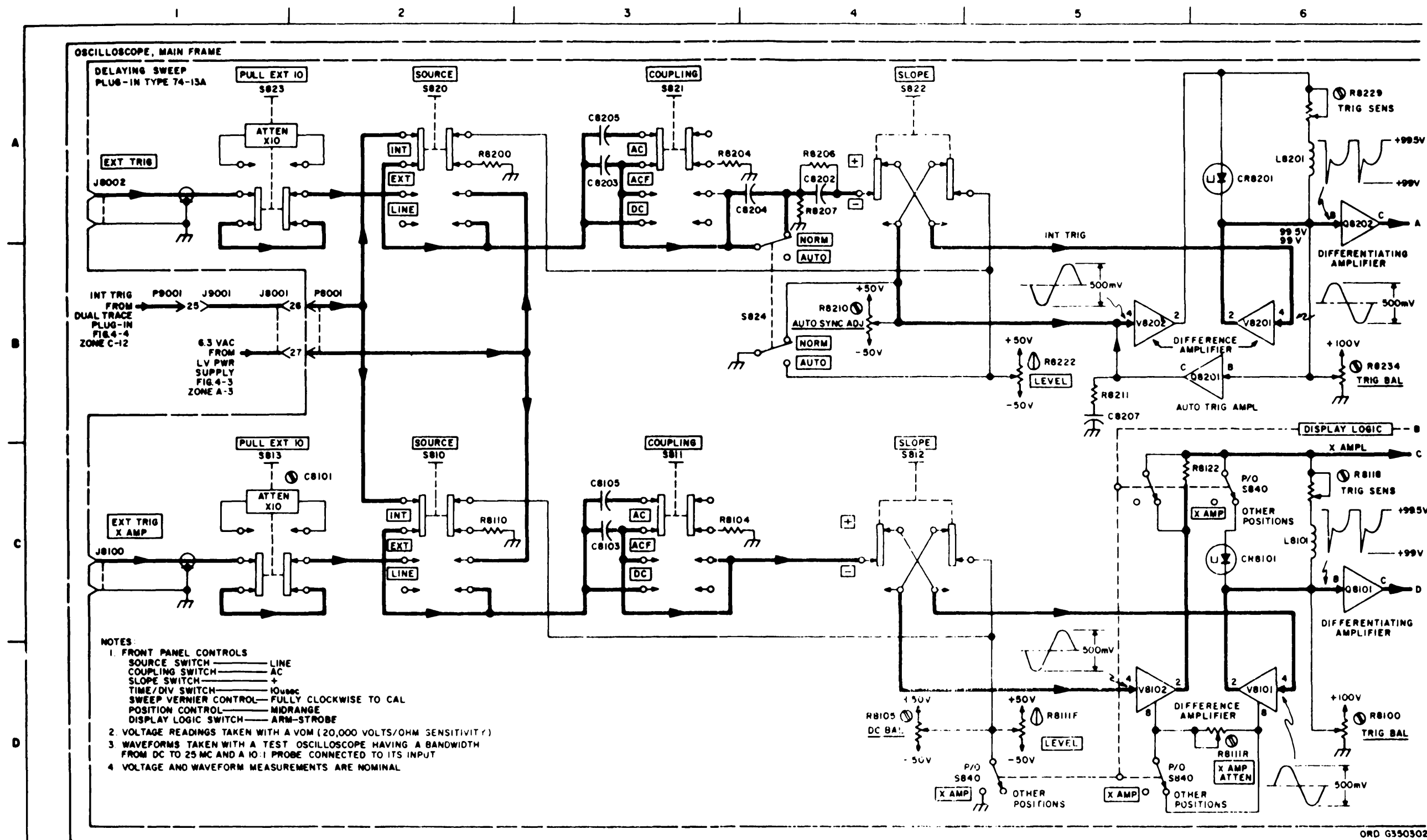

Figure 4-5. Delaying sweep plug-in (type 74-13A), functional schematic (sheet 1 of 3)

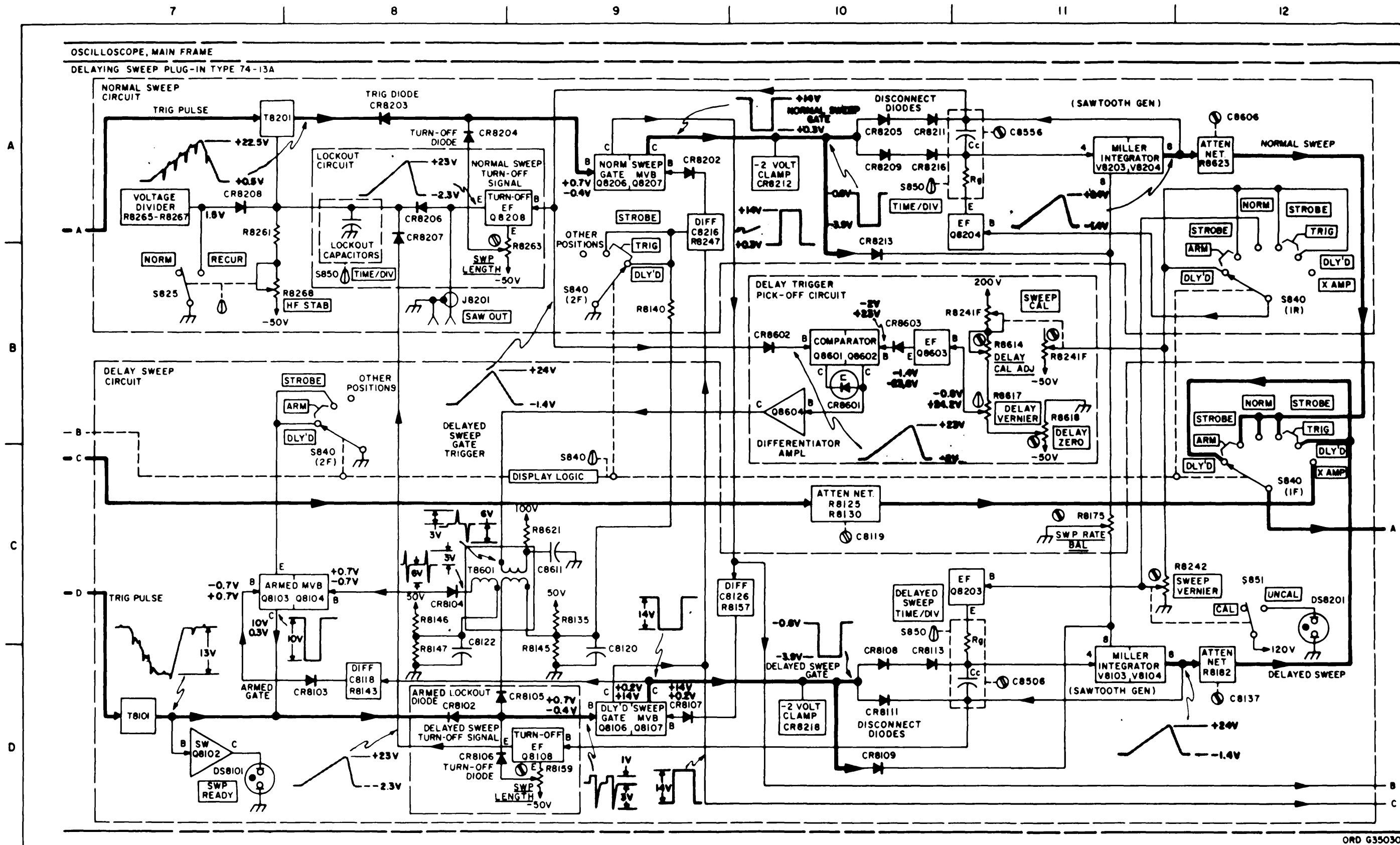

Figure 4-5. Delaying sweep plug-in (type 74-13A), functional schematic (sheet 2 of 3).

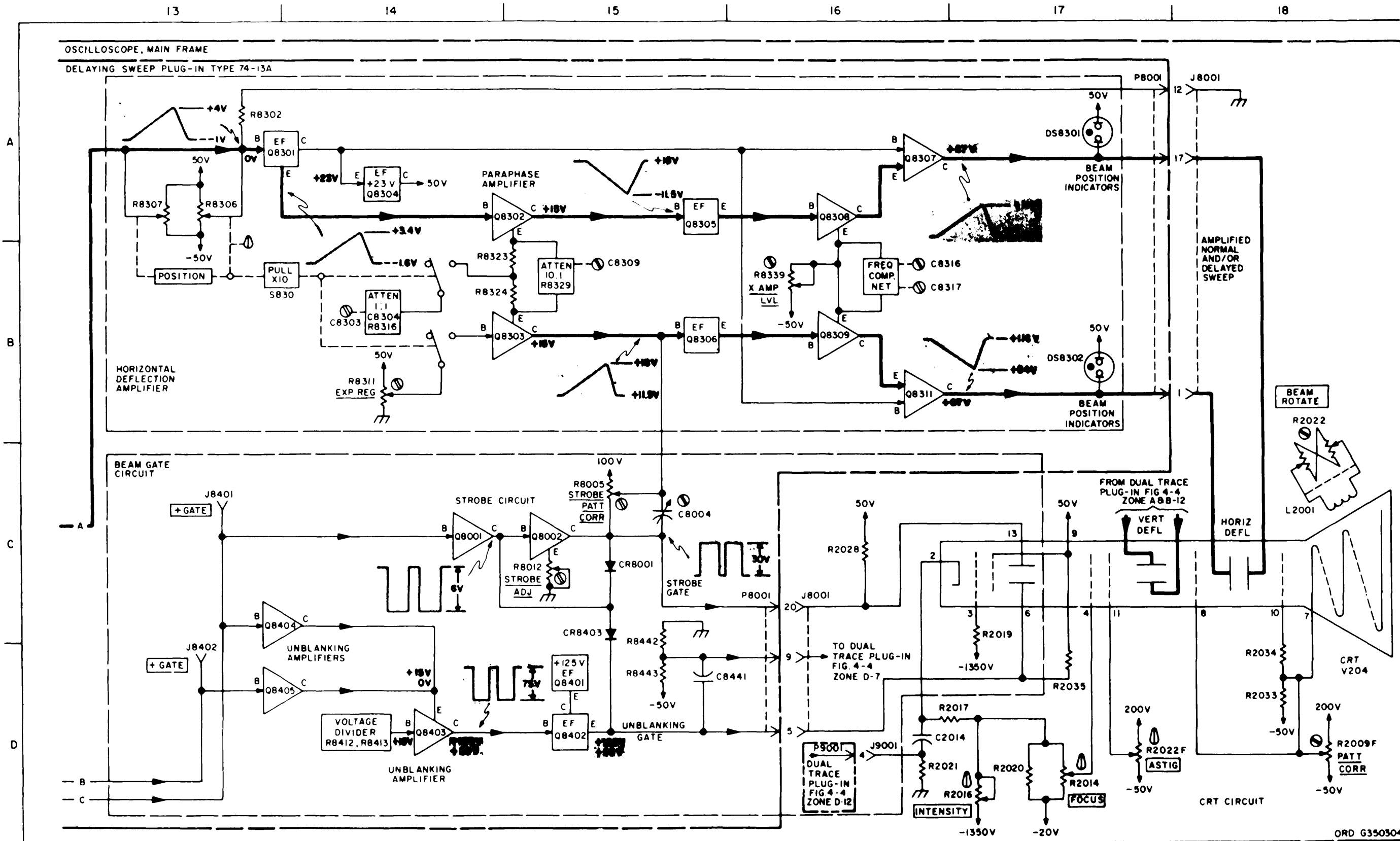

Figure 4-5. Delaying sweep plug-in (type 74-13A), functional schematic (sheet 3 of 3).

CHAPTER 5

MAINTENANCE INSTRUCTIONS

Section I. REPAIR PARTS, TOOLS, AND EQUIPMENT

5-1. General

Repair parts, tools, and equipment are issued to using personnel for operating and maintaining the oscilloscope. Tools and equipment should not be used for purposes other than those prescribed, and when not in use, they should be properly stored.

5-2. Repair Parts

For the repair parts (parts most likely to become defective under normal operating conditions) that are supplied to the using organization, refer to TM 9-6625-1753-25P. They are to be replaced by the using organization only if the operations required to replace these parts are within the scope of the organizational, direct support, and general support maintenance functions.

5-3. Common Tools and Equipment

Standard and commonly used tools and equipment having general application to this materiel are authorized for issue by tables of allowances and tables of organization and equipment.

Caution: To prevent damage to the equipment, assure that the power is off before inserting plug-in units into, or removing these units from the main frame.

Section II. PREVENTIVE MAINTENANCE

5-4. General

a. Preventive maintenance is the systematic care, inspection, and servicing of equipment to maintain it in serviceable condition, to prevent breakdowns, and to insure maximum operational readiness.

b. Preventive-maintenance services in this section are the responsibility of the using organization. Every organization equipped with the oscilloscope must thoroughly train its personnel to perform the required preventive-maintenance services. These services consist of monthly, and semiannual services, to be performed primarily by the organizational maintenance personnel.

5-5. Preventive Maintenance Checks and Services

Table 5-1 lists the preventive maintenance checks and services for the oscilloscope.

Warning: Deenergize the oscilloscope before performing preventive maintenance.

5-6. Lubrication Instructions

Lubricate the runner slides every 3 months with a light coating of instrument grease MIL-G-23827. Lubricate the fan motor shaft every month. This can be accomplished by removing the motor, rubber-stop cup and applying a small amount of lubricating oil MIL-L-6085A. There are no other lubrication requirements for the oscilloscope.

5-7. Precautions

a. Never use steel wool to clean this equipment. Minute particles may lodge in the compartments and cause short circuits.

b. Never use a damp or wet cloth to clean wiring or electrical connections.

c. Do not use cleaning compound (solvents) to clean electrical contacts or the CRT graticule scale.

5-8. Cleaning Instructions

Warning: Deenergize the oscilloscope before cleaning.

a. Wipe all dust from the front panel and cabinet with a clean dry cloth. Wipe all dust from exposed internal parts of the oscilloscope. If necessary, dampen the cloth with cleaning compound (6810-281-1985) and then wipe the parts with a clean, dry cloth. Use a clean, dry brush to remove dust from control shafts, wiring and other restricted areas.

b. Clean the graticule scale with a clean cloth dampened with water and wipe dry with a clean soft cloth. Be careful not to rub dirt into the engraved scale divisions.

c. Use technical trichloroethane (OT-620) to clean electrical parts whenever necessary.

Warning: Trichloroethane is toxic. Avoid breathing fumes and provide adequate ventilation.

Table 5-1. Preventive Maintenance Checks and Services

No.	Item	Interval		Preventive maintenance checks and services
		Monthly	Semi-annual	
1	Exterior	X		Inspect exposed area for rust, dirt or moisture. Clean or dry as required.
2	Switches, knobs, pilot lights, and controls	X		Tighten as required. Inspect for binding or scraping. Check for cut-out due to dirty or loose contacts by tapping lightly. Replace, repair, or clean as required.
3	Handles	X		Hand check for looseness.
4	Operation	X		Be alert to any unusual operating condition or performance.
5	Cables, probes, connectors	X		Clean and inspect for cuts, broken or frayed wiring.
6	Plug-in runners	X		Inspect the runners for dirt or dust.
7	Plug-in assembly connectors	X		Check for dirty or bent contact connectors.
8	Exterior and interiors	X		Check for cracks, breaks or other damage.
9	Components	X		Check capacitors and resistors for swelling, melted wax, corrosion and have authorized personnel replace them.
10	Screws and nuts		X	Inspect all screws and nuts and tighten.
11	Fan	X		Add a small amount of lubricant to the fan motor shaft.

Section III. TROUBLESHOOTING

Warning: Be extremely careful of high voltages when servicing the oscilloscope. Be especially careful of the +100-volt and +200-volt supplies. These are even more dangerous than +11, 200-volt (nominal) and -1350-volt supplies because they can produce greater current. Turn off the oscilloscope and disconnect the power cord before removing the oscilloscope from the fiberglass case. When making interior checks or adjustments with the power on, use only one hand and don't grasp the oscilloscope chassis or any grounded object with the free hand.

Warning: Be extremely careful when handling the cathode-ray tube. Flying glass resulting from tube implosion can cause severe injury. When possible, leave the graticule scale in place to protect the tube face.

5-9. General

Locating the source of troubles on the oscilloscope can, in many instances, be accomplished by observing the cathode-ray tube screen, while making the various control settings for the different operating modes. Other faults, such as burned resistors and diodes, shorted transformers, and defective switches can be located by sight, smell, hearing, and touch. Troubleshooting tables are furnished to aid the using personnel in locating the source of a trouble that can't be found by the

sight, smell, hearing and touch method. These tables list the malfunctions, probable causes, and corrective actions for the main frame, dual trace plug-in, and delaying sweep plug-in. Obviously, such tables can't include every trouble symptom that may occur. However, using personnel should use the tables, in conjunction with the functional and schematic diagrams, as a guide in analyzing faults that may not be listed in the tables.

Table 5-2. Troubleshooting the Main Frame

Malfunction	Probable case	Correct action
Power-on indicator does not illuminate.	Lamp open. No input power. Thermal relay cut-out (relay S103) has opened because of excessive heat. Line fuse F101 is open. Primary of transformer T1001 is not connected to proper voltage source.	Replace lamp DS1001. Check power source. Check power input cable. Check that both plug-in assemblies are securely locked to the main-frame connectors. Check thermal relay S103. Check operation of fan (thermal relay S1 is closed when fan is on). Replace fuse (fig. 5-1). Check that 230v/115v switch S101 is set to the proper input voltage (fig. 5-2).
Line fuse opens after power is turned on.	Shorted rectifier and/or shorted filter capacitor in low-voltage power supply or fan circuit. Short in transformer T1001.	Starting with the -50 volts power supply, check power supply rectifiers and filter capacitors for shorts. Check for short in transformer primary and secondary windings (fig. 5-3). Replace fan assembly (fig. 5-3)
Fan fails to operate when thermal relay S1 closes.	Burned-out fan motor.	Replace fan assembly (fig. 5-3)
Heater fails to operate when temperature drops below 41°F.	Thermal relay S1201 remains opens.	Check relay. Replace if defective.
Complete failure in one or more of the power supply voltage regulators, and line voltage correct.	Fuse is open.	Check and replace any opened fuses in the regulated power supplies (fig. 5-1).
Incorrect output voltages from one or more regulators.	-50 volts regulators misadjusted. Defective component within the power supply voltage regulators.	Set the -50 volts regulator for an output voltage of -50 volts and then, in turn, read just the 50 volts, 100 volts, and 200 volts regulators to the correct voltage (fig. 5-5). Starting with the -50 volts regulator, systematically check each stage for proper voltages until defective component is isolated. Replace component.
Power-on indicator illuminates but no trace on CRT.	Broken lead from CRT filament winding.	Replace lead.
Power-on indicator illuminates but no trace on CRT.	INTENSITY control too low. Delaying trigger LEVEL control, normal trigger LEVEL control, or the delaying sweep plug-in POSITION control is improperly set.	Adjust INTENSITY control. Set controls to proper level.

Table 5-2. Troubleshooting the Main Frame - Continued

Malfunction	Probable case	Correct action
	No high voltage (765MH and 765 MH/F). No high voltage (765MA). CRT defective.	Check high-voltage rectifiers (fig. 5-2). Check high-voltage oscillator (oscillator grid voltage is -25 volts when oscillator is working) (fig. 5-3). Check transformer T2001 for open or short. Check for the presence of +23 ±2 volts at the emitter of Q2004 using a DC voltmeter. Check for the presence of a 40 kHz sine wave at the collector of Q2005 using the test oscilloscope. This signal should be approximately 30 volts p-p at a frequency of 35-45 kHz. If no oscillation is observed, turn off the power and check Q2005, CR3001, CR3002 and the continuity of windings on T2001. Replace CRT.
Poor regulation of high voltage.	High-voltage regulator tube defective. Shorted negative high-voltage rectifiers. Incorrect bias on high-voltage regulator.	Replace V201 (fig. 5-3). Check CR203-CR205 (fig. 5-2). Using HV ADJ resistor, adjust bias to -51 volts.

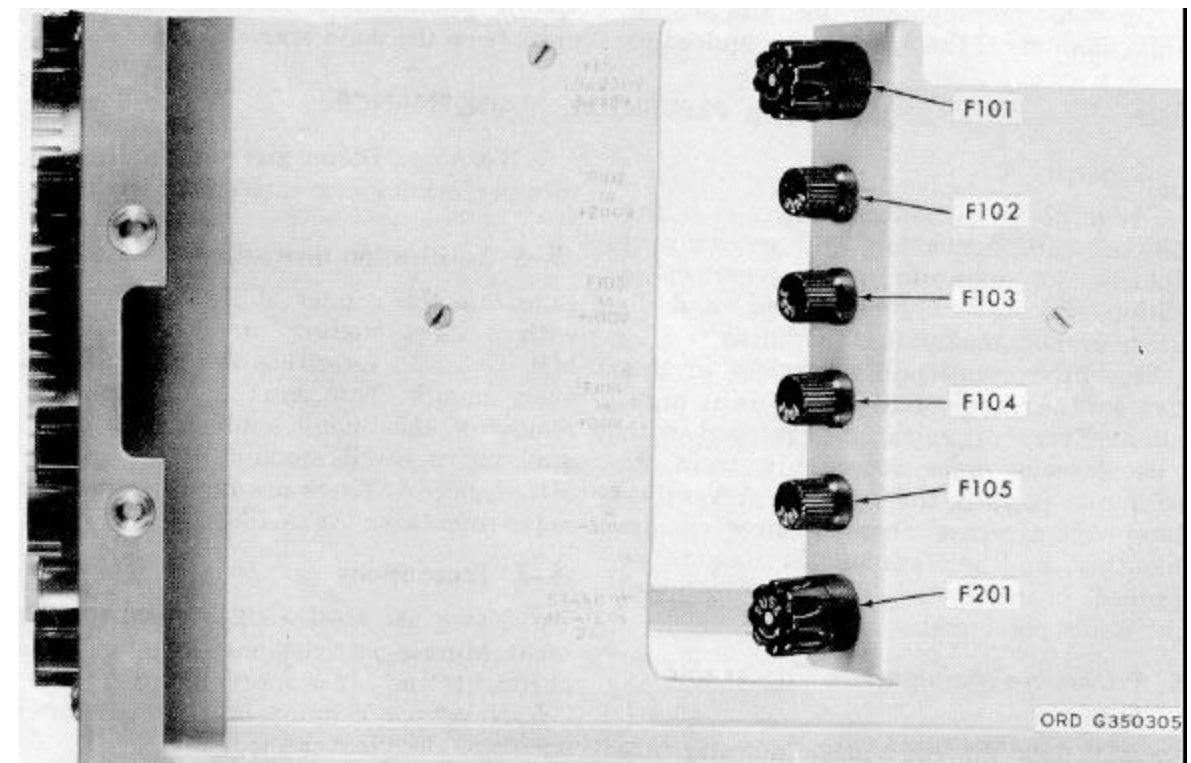

Figure 5-1. Main frame, oscilloscope 765MH, right side view showing fuses.

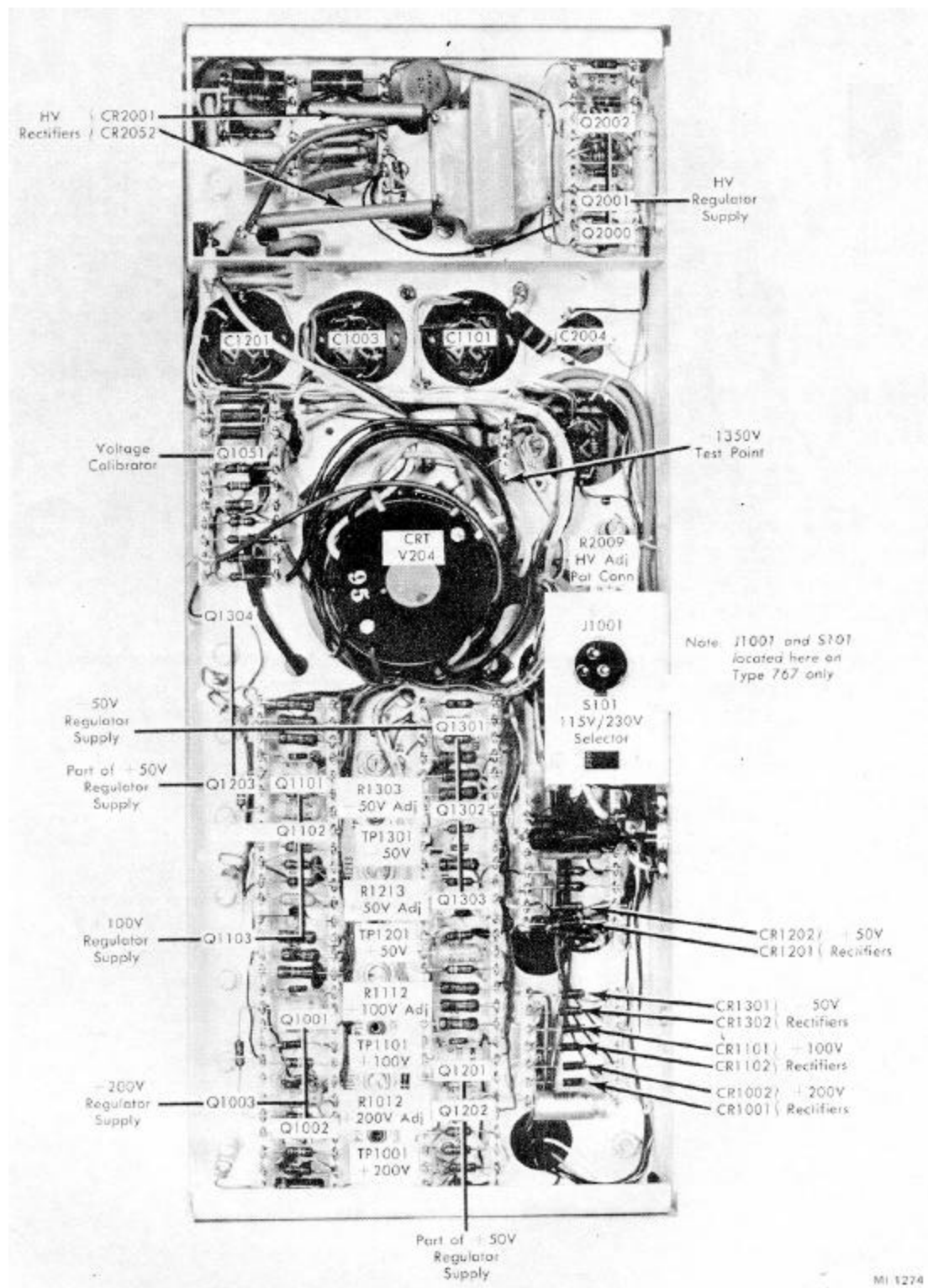

Figure 5-1.1. Main frame, oscilloscope, 765MH/F and newer model 765MH (rear view).

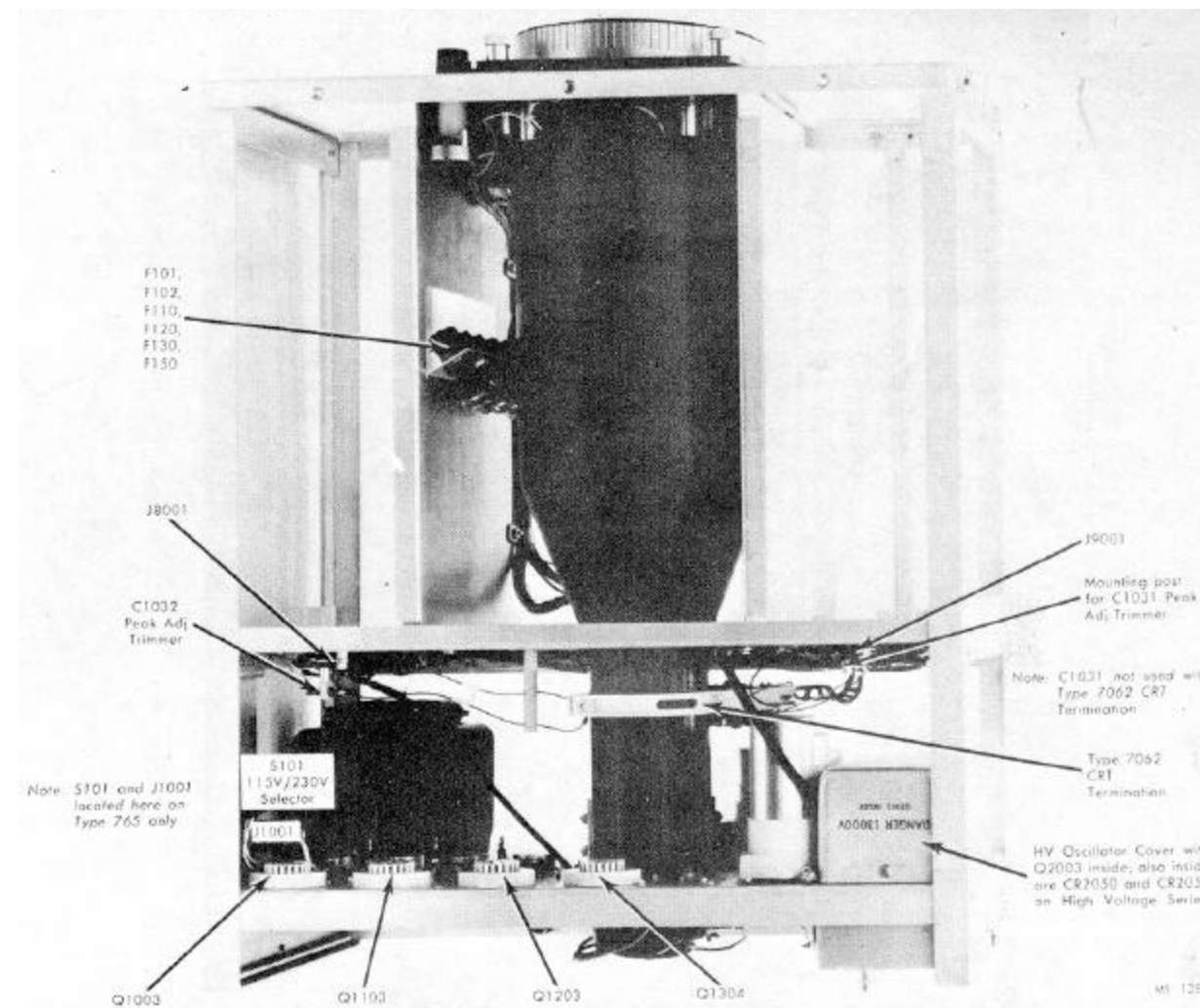

Figure 5-1.2. Main frame oscilloscope 765 MH/F and newer model 756 MH (top view)

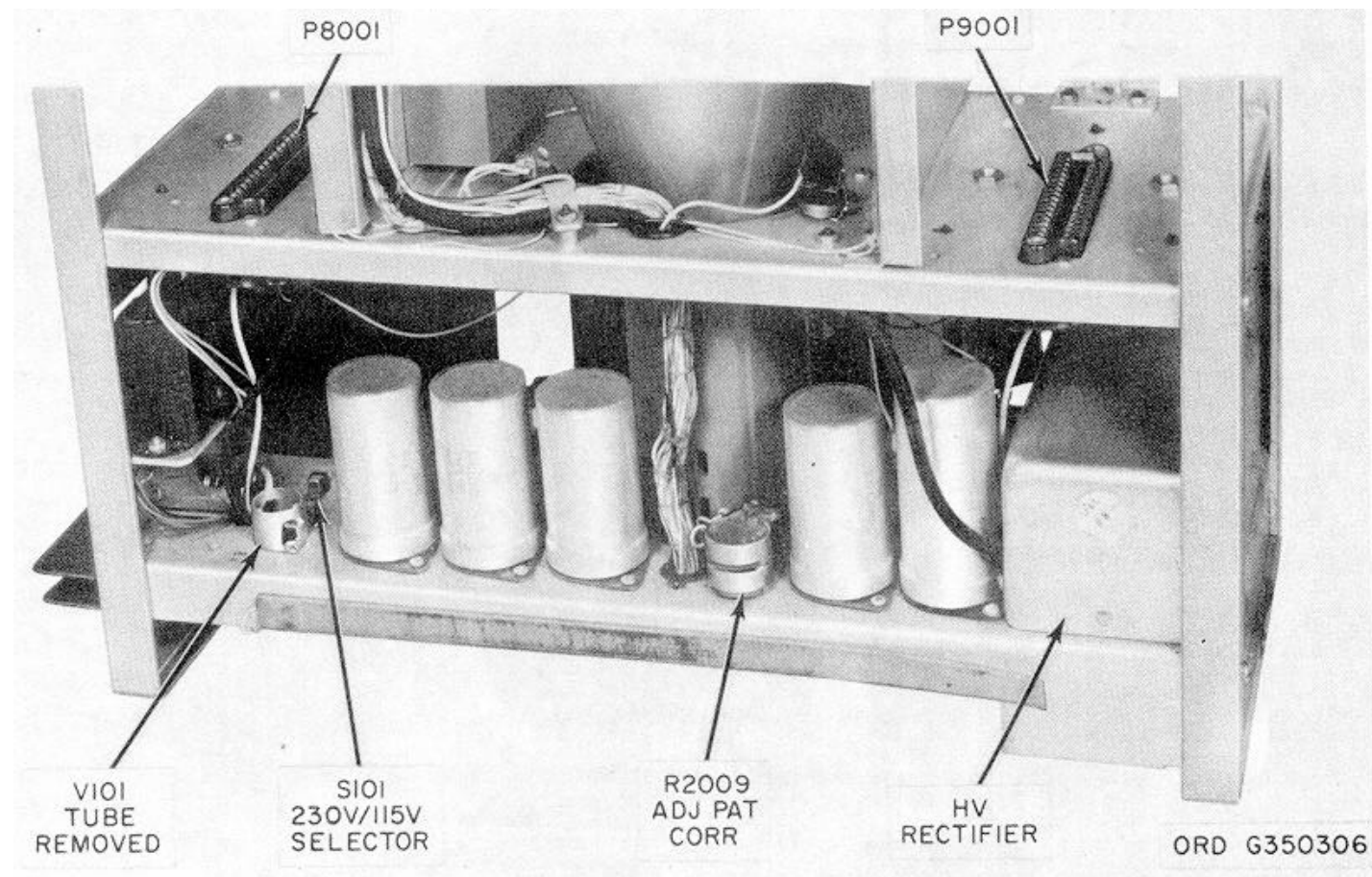

Figure 5-2. Main frame, top view showing connectors, switch, and HV rectifier.

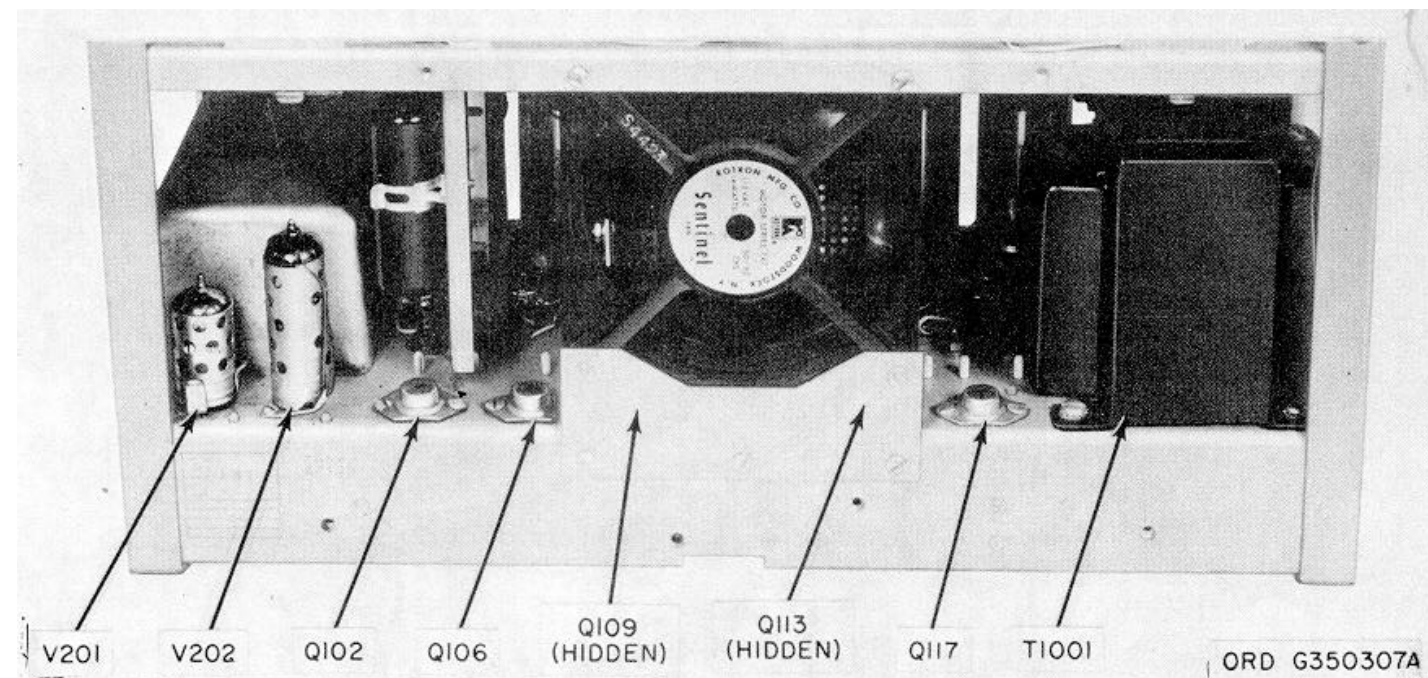

Figure 5-3. Main frame, oscilloscope 765MH, bottom view showing tubes, transistors, and transformer.

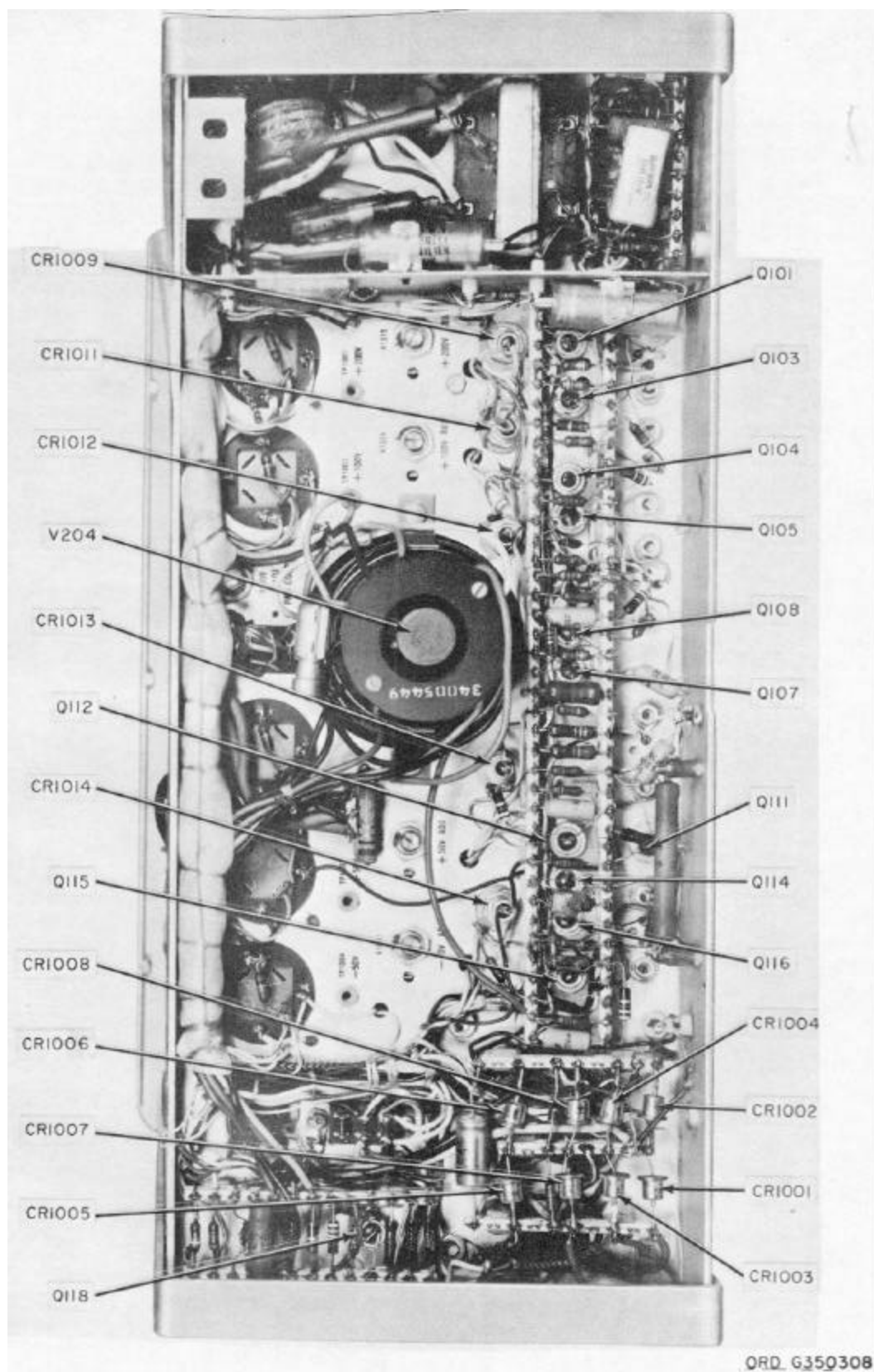

Figure 5-4. Main frame, oscilloscope 765MH, rear view showing diodes, transistors, and CFT.

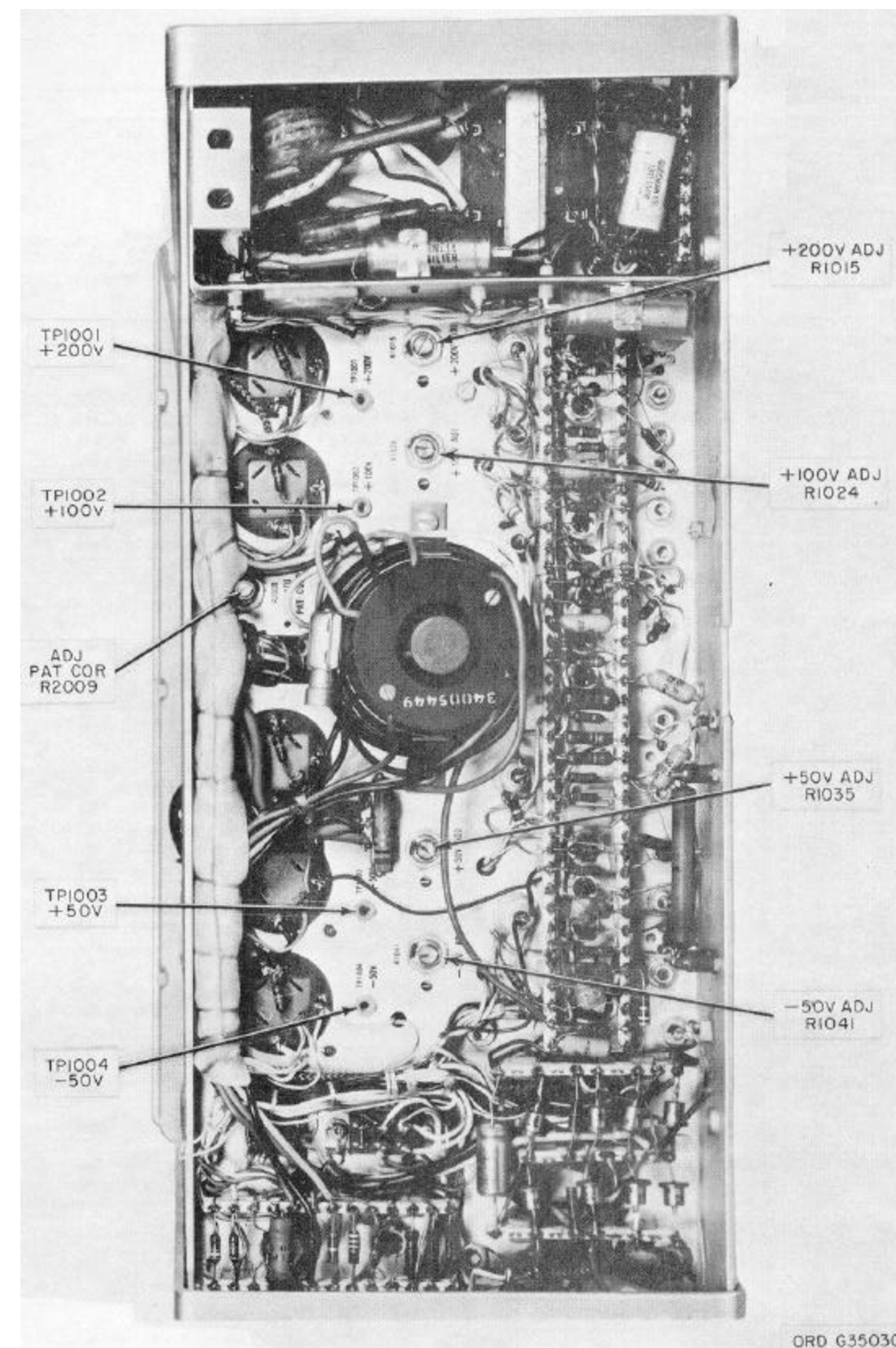

Figure 5-5. Main frame, rear view showing adjustments and test points.

Table 5-3. Troubleshooting Dual Trace Plug-In Type 76-02A

Malfunction	Probable cause	Corrective action
No vertical trace on the CRT screen.	Open interlock circuit because the unit connector is not plugged in the main frame connector properly. Defective capacitor C9709 in the blanking circuit. Defective transistors in the blanking circuit.	Reinsert the unit, making sure the connectors are properly mated. Replace the capacitor. Check Q9701, Q9702, Q9703, and Q9704 and replace the defective transistor (fig. 5-7).
Vertical trace appears on the CRT screen, but it has insufficient amplitude.	For channel A only: GAIN ADJ control R9212 is not adjusted properly. Defective stage or stages in the preamplifier. For channel B only: GAIN ADJ control R9312 is not adjusted properly. Defective stage or stages in the preamplifier. Both channels: Defective common output amplifier stages.	Readjust GAIN ADJ control. Check stage-by-stage from Q920 and Q9206 back to the input via Q9202, Q923, Q9201, Q99200, V921, and V920 and replace the defective transistor, tube, or component (fig. 5-7). Measure the voltages as shown on the functional schematic to help isolate the defective stage. Readjust GAIN ADJ control. Check stage-by-stage from Q9304 and Q930 back to the input via Q9303, Q9302, Q9301, Q9300, V931, and V930 and replace the defective transistor, tube, or component (fig. 5-7). Measure the voltages at the same points on channel B as shown in the functional schematic for channel A to help isolate the defective stage. Check stage-by-stage from Q9409 and Q9408 back to Q9401 and Q9400 via Q940, Q9104, Q9414, Q9413, Q9403, and Q9402 and replace the defective transistor or component (fig. 6-9). Measure the voltages as shown on the functional schematic to help isolate the defective stage.
MODE switch in CHOP position, only one channel is displayed.	Defective MODE switch. Defective diode CR9704 in the blanking circuit. Defective transistors in the blanking circuit. Defective transistors or components in the electronic switch circuit.	Replace switch 960. Replace diode. Replace Q9701, Q9702, Q9703, and Q9704 (fig. 5-7). Replace Q9600 and Q9601 or the defective components (fig. 5-7).
MODE switch in ALT position, only one channel is displayed.	Defective MODE switch. Defective switching diodes CR9201 or CR9301, depending on which channel is not displayed.	Replace switch S960. Replace switching diodes.

Table 5-3. Troubleshooting Dual Trace Plug-In Type 76-02A - Continued

Malfunction	Probable cause	Corrective action
	Defective transistors in the blanking circuit. Defective electronic switch circuit.	Replace Q9701, Q9702, Q9703, and Q9704 (fig. 5-7). Replace Q9600 and Q9601 or the defective components (fig. 5-7).
NORM-INVERT switch in AC position doesn't block the dc component of input signal.	Defective dc blocking capacitor, depending on the channel to be displayed.	Replace capacitor C9115 for channel A. Replace capacitor C9915 for channel B.
Trace can't be centered on either channel when the POSITION control is rotated.	Defective stage in the preamplifier circuit. Defective POSITION control.	Check Q9205, Q9204, Q9203, Q9202, Q9201, Q9200, V921, and V920 for channel A and replace the defective component in these stages. Check Q9305, Q9304, Q9303, Q9302, Q9301, Q9300, V931, and V930 for channel B and replace the defective component in these stages (fig. 5-7). Replace POSITION control R9234 for channel A and POSITION control 19334 for channel B.
Horizontal trace moves up and down as the VARIABLE control is rotated. Can't be corrected by adjusting the DC BAL control.	Defective paraphrase amplifiers. Defective dc balance network at the grid of V921 or V931.	Replace defective V920, V921 and their associated defective components for channel A. Replace defective V930, V931 and their associated defective components for channel B (fig. 5-7). Replace the defective network component.
VARIABLE control has no effect, or doesn't cause a smooth change in the vertical deflection as it is rotated.	Defective VARIABLE control:	Replace control R9213 (channel A) or control R9313 (channel B).
Poor frequency response.	Defective stage in the preamplifier circuit. Defective stage in the vertical deflection amplifier.	Check Q9205, Q9204, Q9203, Q9202, Q9201, Q9200, V921 and V920 for channel A and replace the defective component in these stages. Check Q9305, Q9304, Q9309, Q9302, Q9301, Q9300, V931, and V930 for channel B and replace the defective component in those stages (fig. 5-7). Check Q9409, Q9408, Q9407, Q9406, Q9405, Q9404, Q9413, Q9414, Q9403, Q9402, Q9401, and Q9400 for both channels and replace the defective component in these stages (figs. 5-7 and 5-9).
Internal triggering doesn't function properly.	Defective trigger pick-off amplifier circuit.	Check Q9501, Q9502, Q9503, Q9504, and Q9505 and replace the defective component in these stages (fig. 5-9).

Table 5-3. Troubleshooting Dual Trace Plug-In Type 76-02A - Continued

Malfunction	Probable cause	Corrective action
Beam position indicator doesn't function.	Defective transistor or component in the Q9504 stage. Defective beam position indicator.	Replace Q9504 or the defective component (fig. 5-9). Replace DS9501 or DS9502.

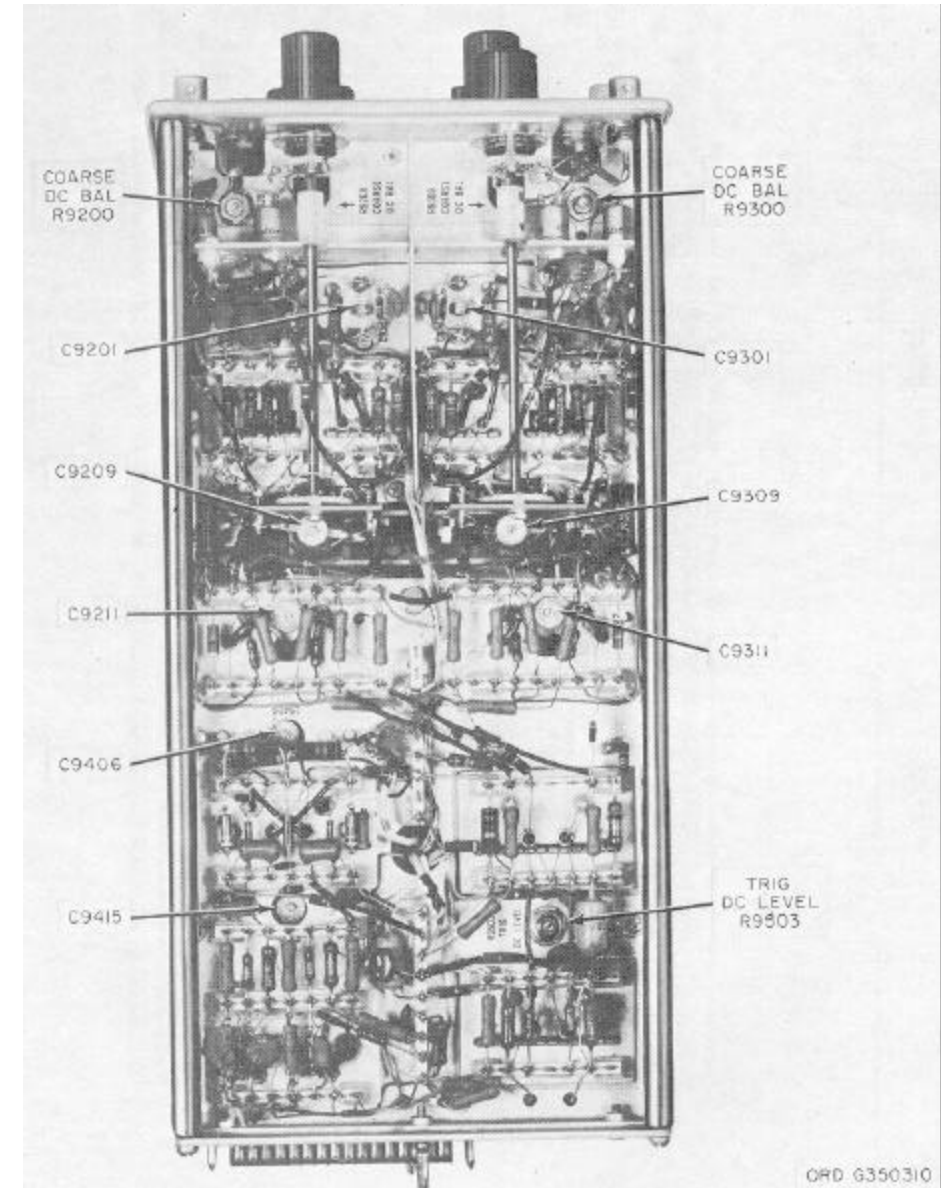

Figure 5-6. Dual trace plug-in, left side view showing adjustments.

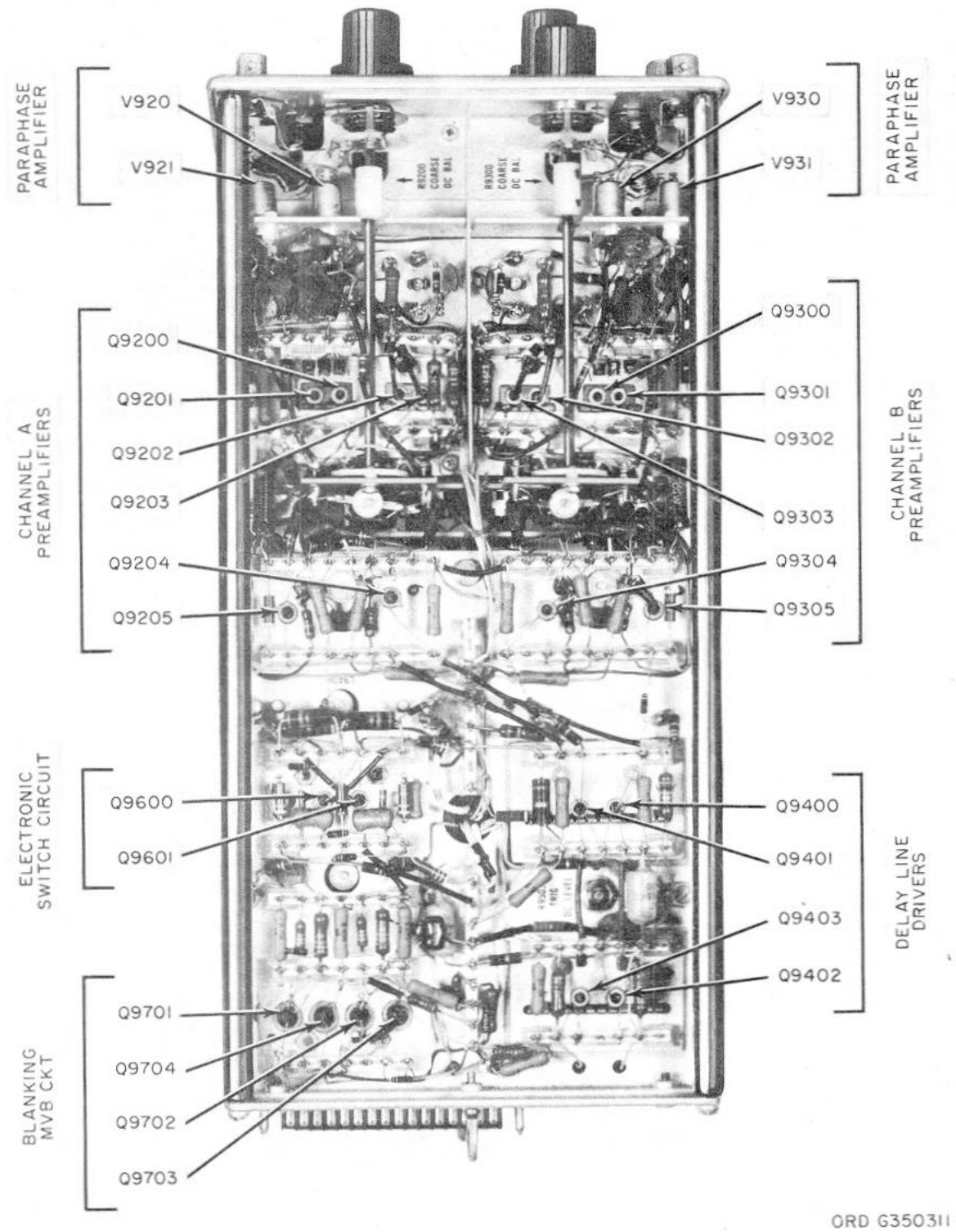

Figure 5-7. Dual trace plug-in, left side view showing transistors and nuvistors (tubes).

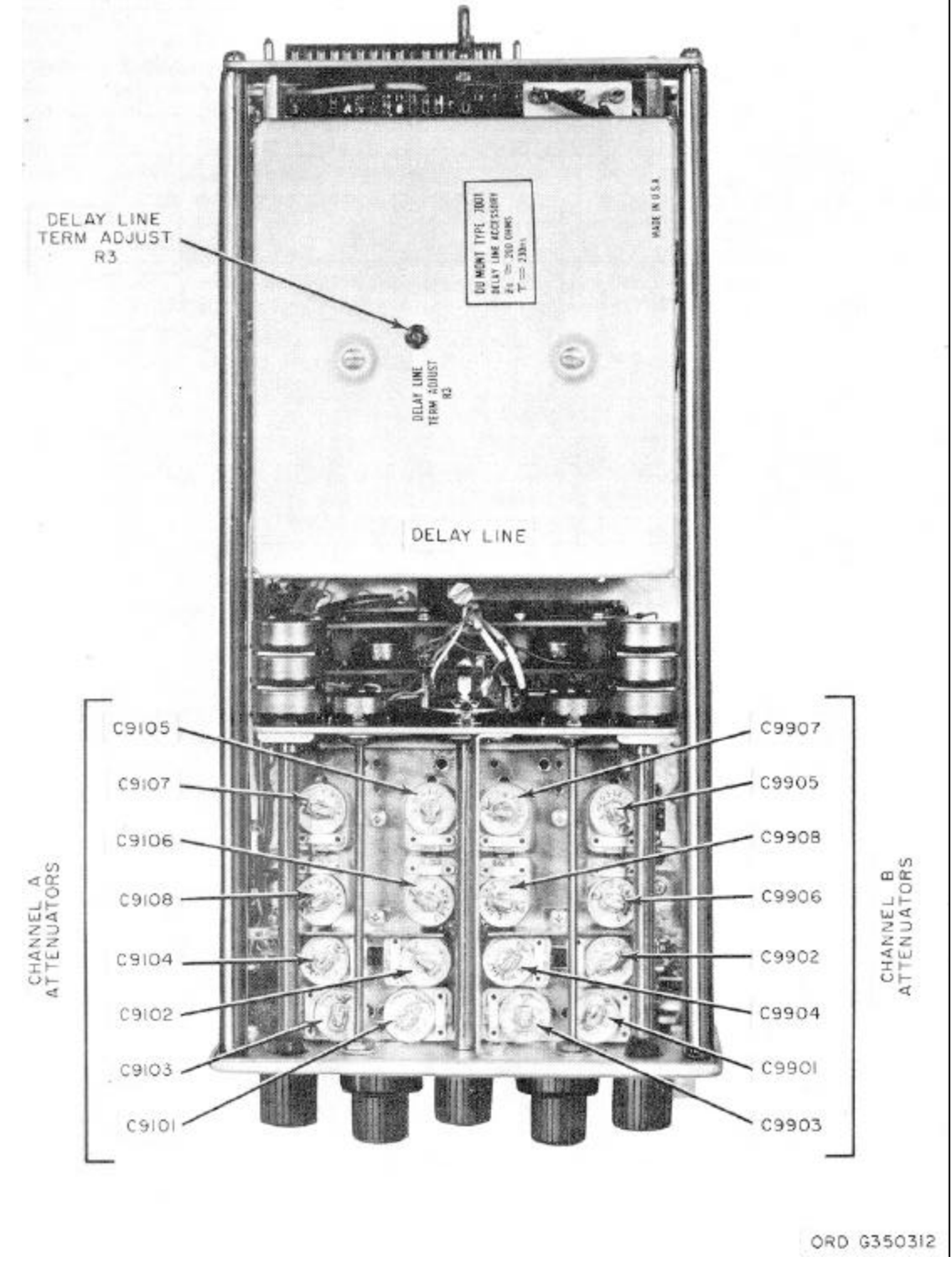

Figure 5-8. Dual trace plug-in, right side view showing adjustments.

Table 5-4. Troubleshooting Delaying Sweep Plug-in Type 74-13A

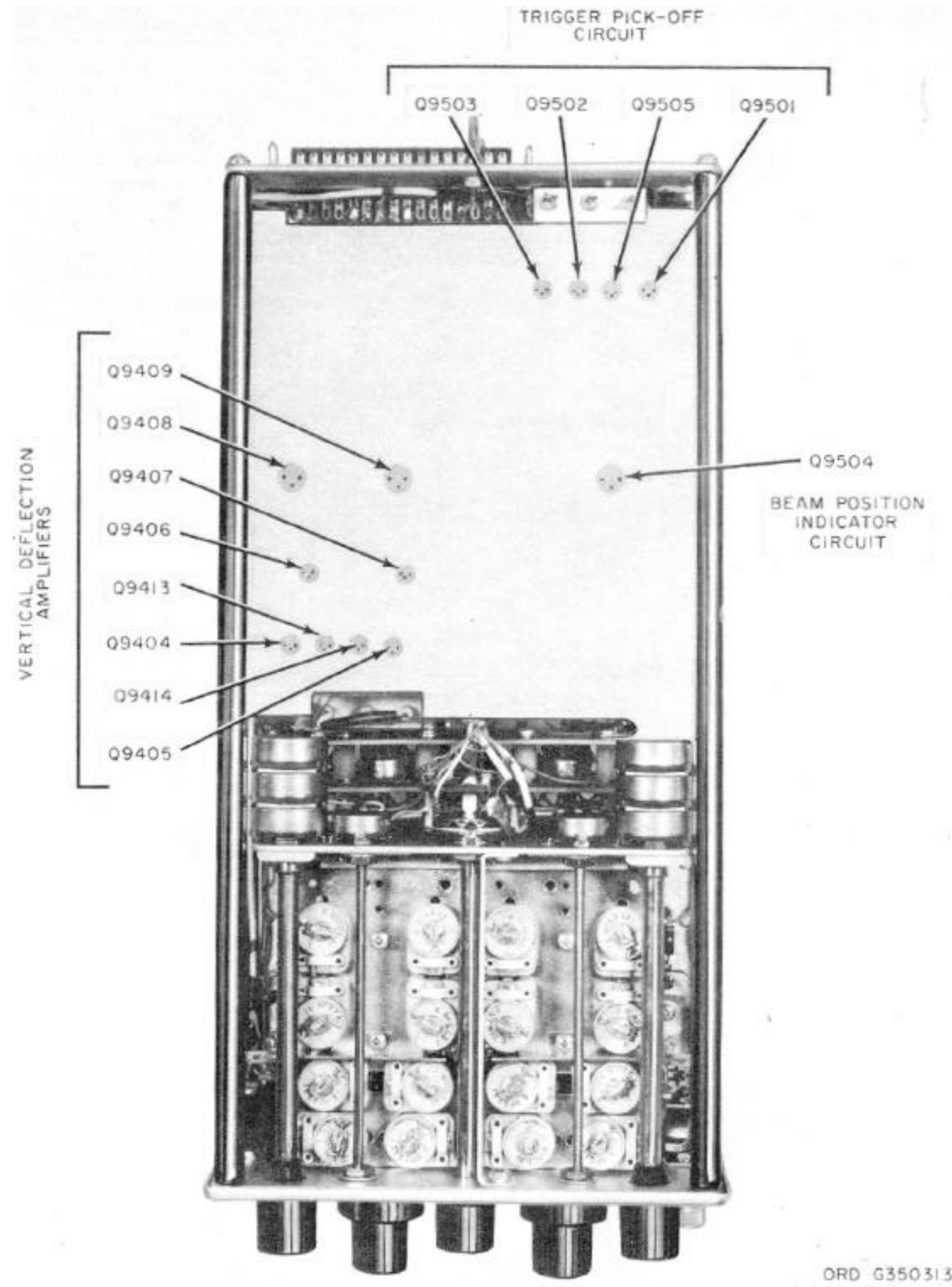

Figure 5-9. Dual-trace plug-in, right side view showing transistors.

Malfunction	Probable cause	Corrective action
CRT screen is blank.	Open interlock circuit because the unit connector isn't plugged in the main frame connector properly.	Reinsert the unit, making sure the connectors are properly mated.
	Defective unblanking amplifier circuit.	Check Q8401, Q8402, Q8403, Q8404, Q8405 and their associated components; replace the defective transistor or component (fig. 5-12). Measure the voltages as shown on the functional schematic to help isolate the defective stage and component.
	Defective delayed-sweep gate or normal-sweep gate multivibrator.	Check Q8106, Q8107, or Q8206, Q8207 and their associated components; replace the defective transistor or component (fig. 5-11).
	No trigger output from differentiating amplifier (shaper) Q8101 or Q8202.	Check Q8101 or Q8202 and its associated components; replace the defective transistor or component (fig. 5-11). Check trigger amplifier circuit V8201, V8202 (normal) and their associated components including tunnel diode CR8201; replace the defective tube or component (fig. 5-12). Check trigger amplifier circuit V8101, V8102 (delayed) and their associated components including tunnel diode CR8101; replace the defective tube or component (fig. 5-12).
	TRIG-STROBE, TRIG-DLY'D, or ARM-STROBE sweep modes: Defective stage in the strobe circuit.	Check Q8001 and Q8002 and their associated components; replace the defective transistor or component (fig. 5-12).
TRIG-STROBE, TRIG-DLY'D, or ARM-STROBE sweep modes: Defective stage in the delay trigger pick-off circuit.	Check Q8601, Q8602, Q8603, and Q8604 and their associated components; replace the defective transistor or component (fig. 5-12).	
Erratic triggering or no triggering at any position of the SLOPE switch.	Defective trigger amplifier or trigger shaper stage.	Check trigger amplifier V8201, V8202 (normal) or trigger amplifier Q8101, V8102 (delayed) and their associated components; replace the defective transistor or component. Check trigger shaper circuits Q8202 (normal) and Q8101 (delayed) and their associated components; replace the defective transistor or component (fig. 5-12).

Table 5-4. Troubleshooting Delaying Sweep Plug-In Type 74-13A - Continued

Malfunction	Probable cause	Corrective action
Erratic triggering or no triggering with AUTO-NORM switch at AUTO.	Defective automatic trigger circuit.	Check Q8201 and its associated components; replace the defective transistor or component (fig. 5-12).
Does not trigger when the COUPLING switch is set to AC.	Open capacitors C8205, C8203 (normal sweep); capacitors C8105, C8103 (delayed sweep).	Replace the defective capacitor.
Does not trigger when the COUPLING switch is set to ACF.	Open capacitor C8203 (normal sweep), C8103 (delayed sweep).	Replace the defective capacitor.
Insufficient horizontal deflection.	Defective stage in the horizontal deflection amplifier.	Check Q8301, Q8302, Q8303, Q8304, Q8305, Q8306, Q8307, Q8308, Q8309, and Q8311 and their associated components; replace the defective transistor or component (figs. 5-11 and 5-13). Measure the voltages as shown on the functional schematic to help isolate the defective stage.
Sweep rate calibration incorrect at one position of the TIME/DIV switch.	Defective resistor or capacitor in the RC timing circuit.	Replace the defective resistor or capacitor.
Sweeps are not linear.	Defective Miller integrator.	Check V8203, V8204 (normal sweep) and their associated components; replace the defective tube or component. Check V8103, V8104, (delayed sweep) and their associated components; replace the defective tube or component (fig. 5-12). Measure the voltage as shown on the functional schematic to help isolate the defective component.
Sweep is unstable at certain positions of the TIME/DIV SWITCH.	Defective lockout circuit.	Check capacitors C8559 and C8558; replace the defective capacitors.
Sweep is unstable at all positions of the TIME/DIV switch.	Defective lockout circuit.	Check Q8208, capacitor C8563, and diodes CR8207, CR8206; replace the defective transistor, capacitor, or diode (fig. 5-11).
Sweep retrace is visible.	Defective lockout circuit.	Check Q8208, capacitor C8563, and diodes CR8207, CR8206; replace the defective transistor, capacitor, or diode (fig. 5-11).
No output from + GATE connector (normal sweep).	Defective normal-sweep gate multivibrator.	Check Q8206, Q8207 and their associated components; replace the defective component (fig. 5-11). Measure the voltages as shown on the functional schematic to help isolate the defective component.

Table 5-4. Troubleshooting Delaying Sweep Plug-In Type 74-13A - Continued

Malfunction	Probable cause	Corrective action
No output from + GATE connector (delayed sweep).	Defective delayed-sweep gate multivibrator.	Check Q8106, Q8107 and their associated components; replace the defective transistor or component (fig. 5-11). Measure the voltages as shown on the functional schematic to help isolate the defective component.
No output from the SAW connector.	Defective normal-sweep gate multivibrator. Defective disconnect diode. Defective Miller integrator. Defective turn-off emitter follower.	Check Q8206, Q8207 and their associated components; replace the defective transistor or component (fig. 5-11). Check CR8205, CR8209, CR8211, CR8216; replace the defective diode. Check V8203, V8204 and their associated components; replace the defective tube or component (fig. 5-12). Check Q8208 and its associated components; replace the defective transistor or component (fig. 5-11). Measure the voltages as shown on the functional schematic to help isolate the defective stage.
Beam position indicators don't function.	Defective beam position lamps. Defective horizontal deflection amplifier.	Check DS8302, DS8301 and replace the defective lamps. Check Q8301, Q8302, Q8303, Q8304, Q8305, Q8306, Q8307, Q8308, Q8309 Q8311 and their associated components; replace the defective transistors or defective component (figs. 5-11 and 5-13). Measure the voltages as shown on the functional schematic to help isolate the defective stage.

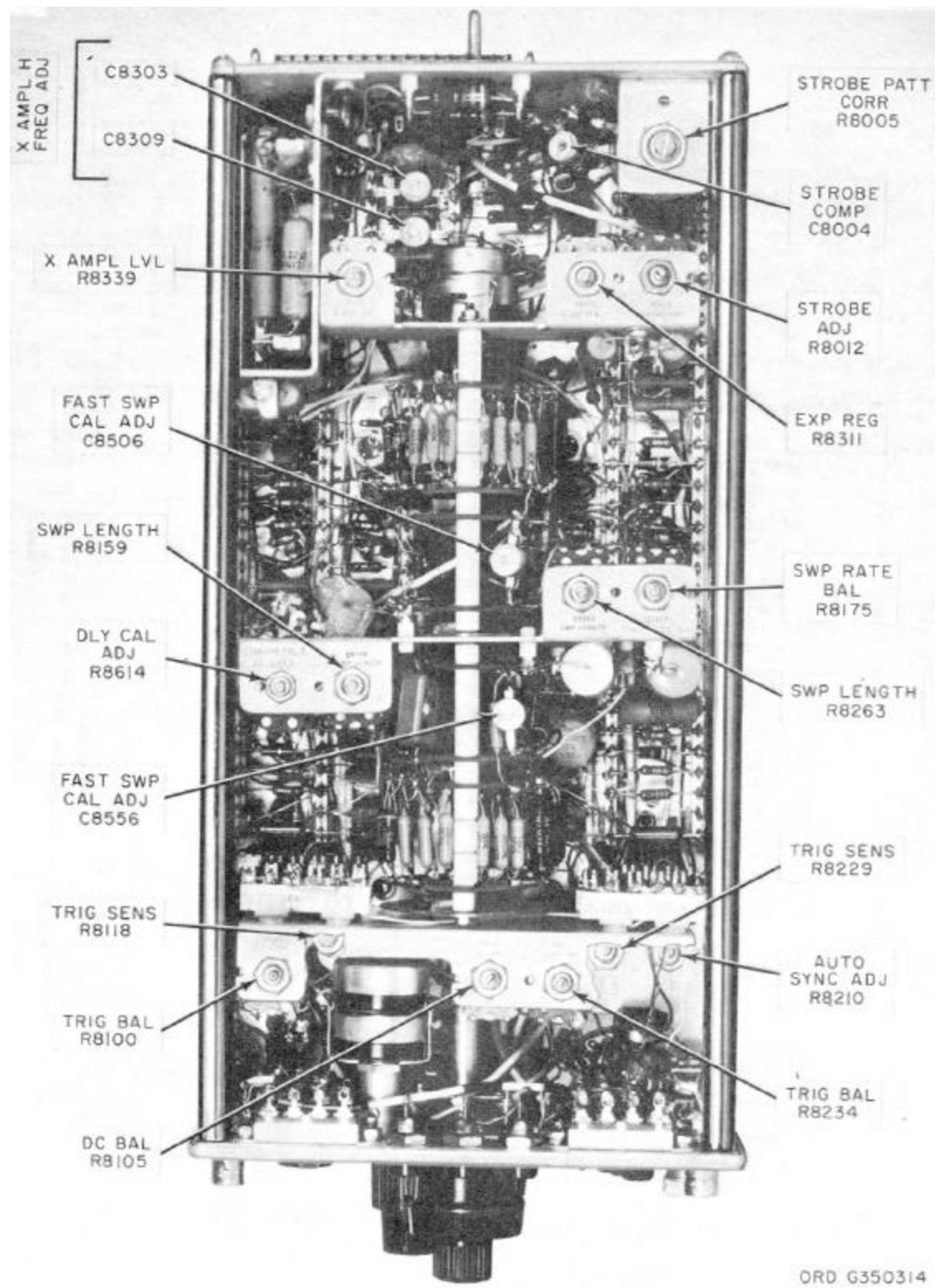

Figure 5-10. Delaying sweep plug-in, right side view showing adjustments.

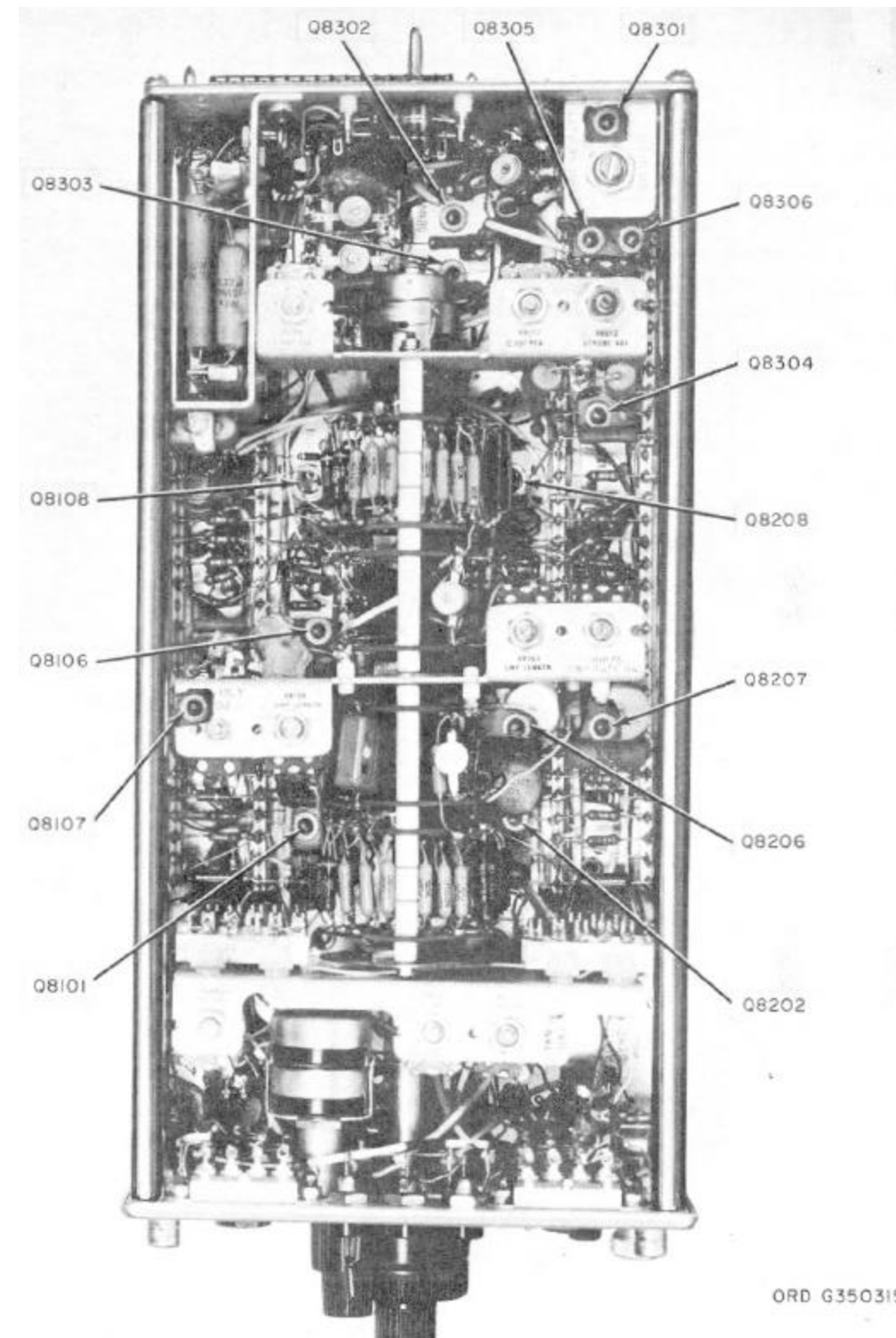

Figure 5-11. Delaying sweep plug-in, right side view showing transistors.

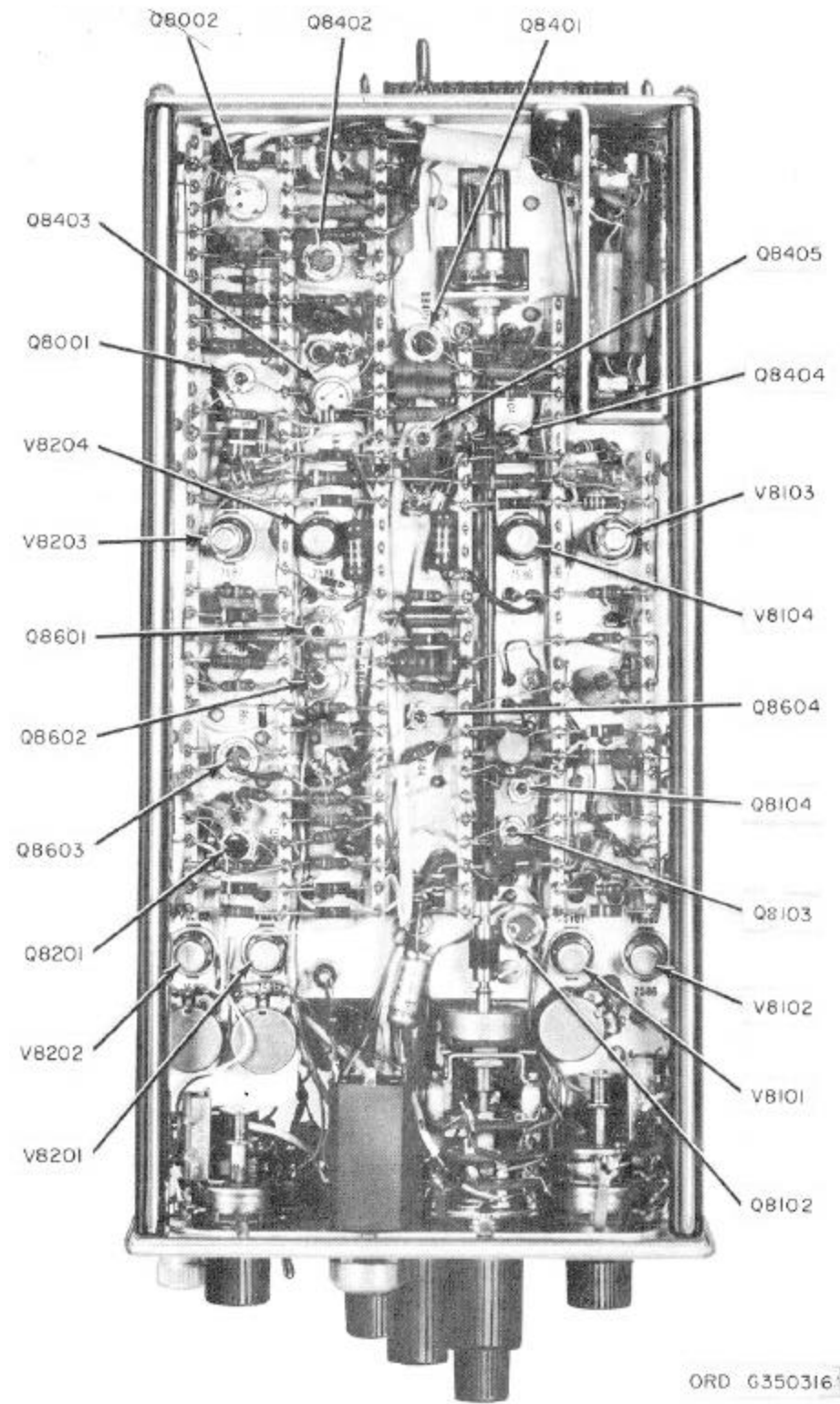

Figure 5-12. Delaying sweep plug-in, left side view showing transistors and tubes.

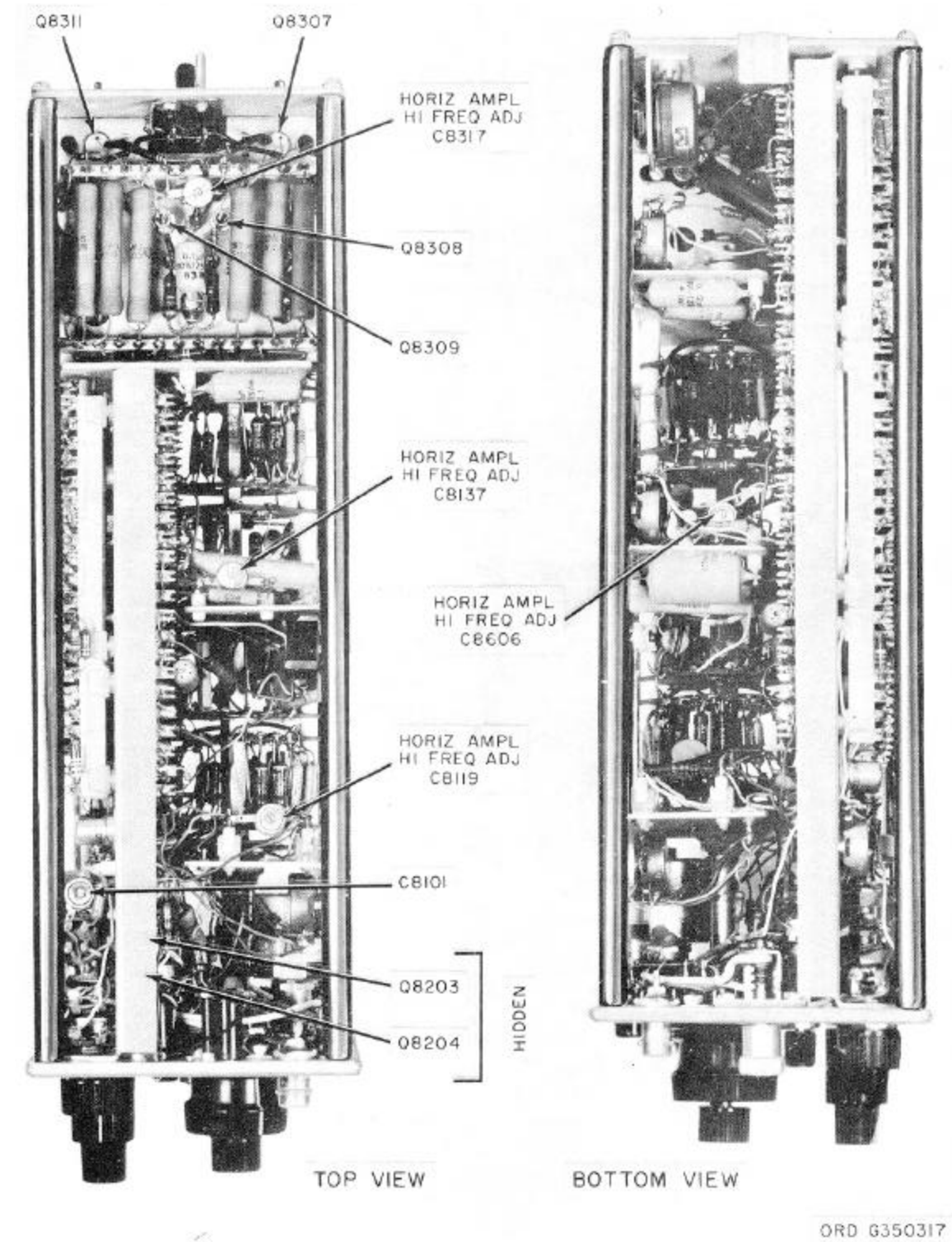

Figure 5-13. Delaying sweep plug-in, top and bottom view showing adjustments and transistors.

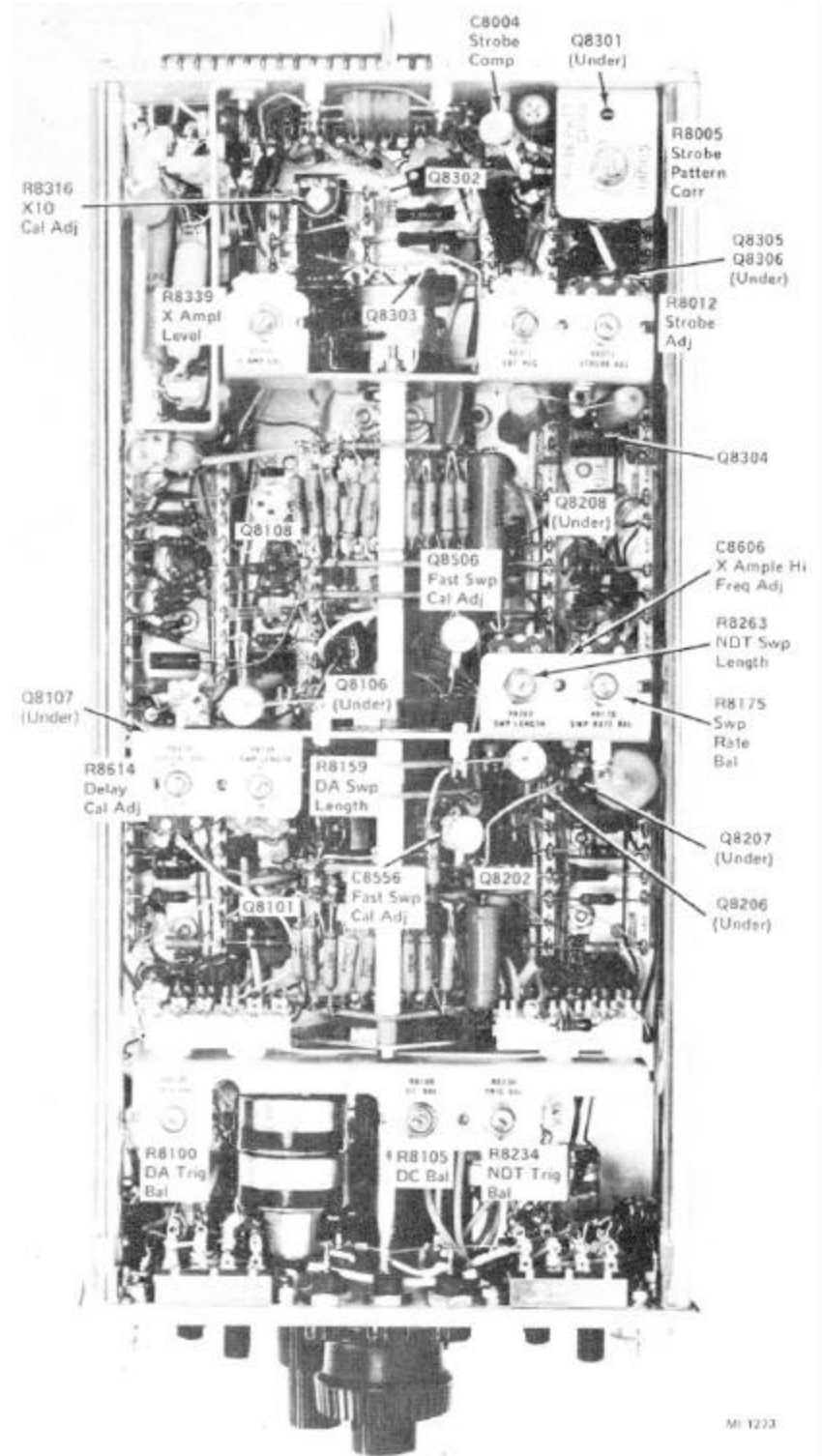

Figure 5-13.01. Delaying sweep plug-in, newer version, right-side view showing transistors and adjustments.

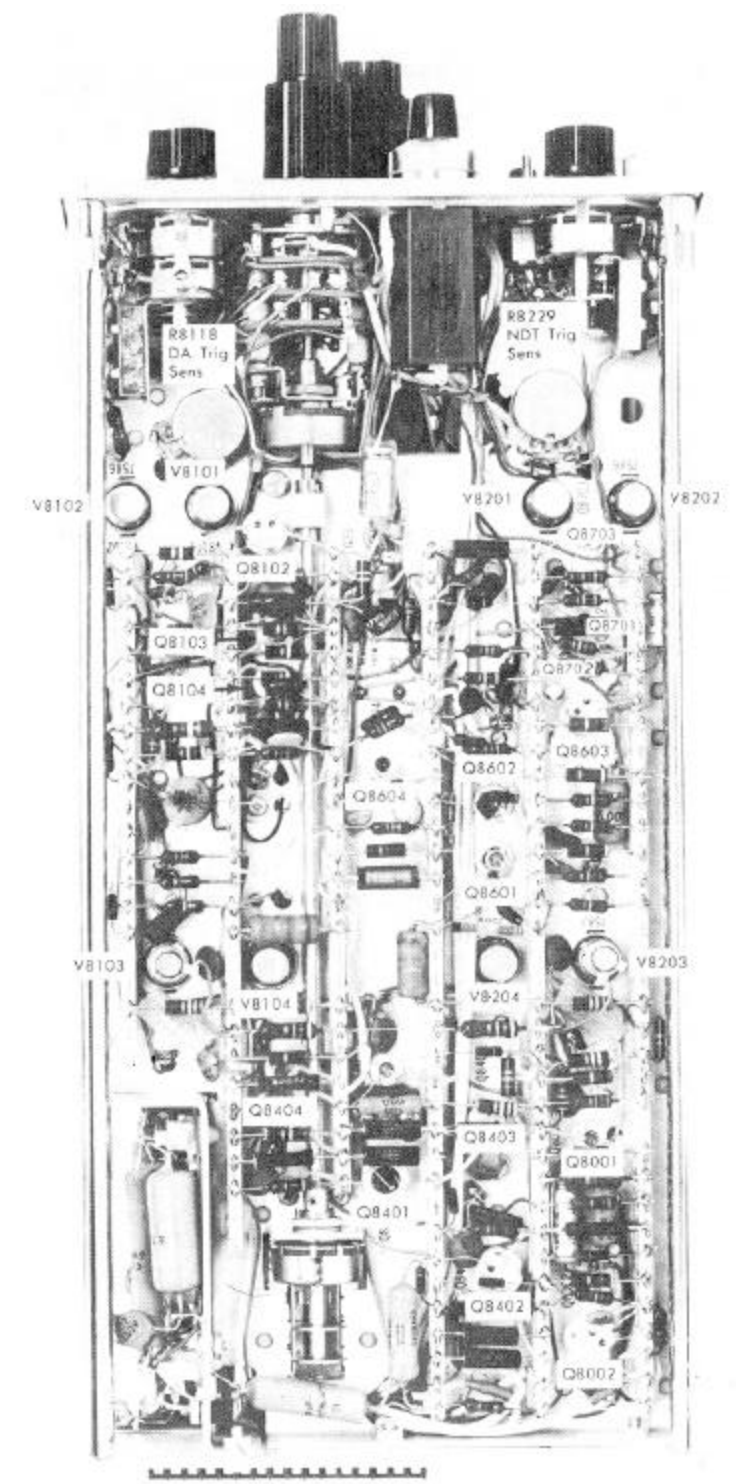

Figure 5-13.02. Delaying sweep plug-in, newer version, left-side showing transistors, nuvistors, and adjustments.

5-9.1. Troubleshooting Dual Trace Plug-In 79-02A

a. *General.* Dual trace plug-in 79-02A, a dc coupled amplifier, contains two preamplifiers, a common amplifier, a gating and control section, and a trigger generation circuit (fig. 4-4.1); front panel controls, available at key points in these circuits, may be used to isolate malfunctions. Using these controls, initial isolation of a malfunction to a suspected group of circuits is relatively easy. The verification that the selected group of circuits is the cause of fault, and the further isolation of the malfunction to a part, should be performed by normal troubleshooting procedures, including signal tracing techniques and voltage and resistance measurements. Methods of using controls in the isolation of malfunctions is discussed in *b* through *d* below.

b. *Weak or missing signals.* Although weak amplification of signals may be noted during use of the instrument, this condition is normally detected or verified when checking the gain of the instrument, using the CAL position of the VOLTS DIV switch. If either channel does not respond properly to the CAL signal, the other channel should be checked. If one channel is weak and the other normal, the channel preamplifier should be suspected as a cause of the malfunction. Since the POSITION control, electrically located in the center of the preamplifier, causes an action very similar to a signal, adjustment of this control simulates a signal applied to the center of the preamplifier. If the preamplifier responds normally to movement of the position control, the malfunction is likely to be electrically located before the control. If both channels are weak, the amplifiers common to both channels, or the switching circuits should be suspected (the calibration voltage is a possible, but unlikely cause of trouble). The switching circuits can be eliminated by measuring the bias on the switching amplifiers.

c. *Improper Switching.* The MODE switch may be used effectively to determine the cause of a switching malfunction. If switching does not occur in the ALT or CHOP modes, the MODE switch should be set to CH1 and CH2 alternately. If the preamplifiers can be switched with manual control, the switching multivibrator and switching amplifiers should not be suspected; instead, the basic timing oscillator should be suspected. If the unit fails to switch with manual control, the switching multivibrator B1 and switching amplifiers should be suspected.

d. *Trigger generation failure.* If the internal trigger will not operate the oscilloscope, the trigger amplitude should be tested to assure that the dual trace plug-in 79-02A is at fault. If the unit is at fault, the faulty circuit may be a normal trigger amplifier, a channel 2 trigger amplifier, or a common section of amplifiers. By switching the TRIGGER switch between NORM and CH2 ONLY, the area of the fault can be localized.

e. *Poor frequency response.* Only the instrument calibration personnel are capable of correcting problems of poor frequency response in this instrument. The instruments issued to support personnel are not suitable for detecting these problems, or for aligning the associated circuits.

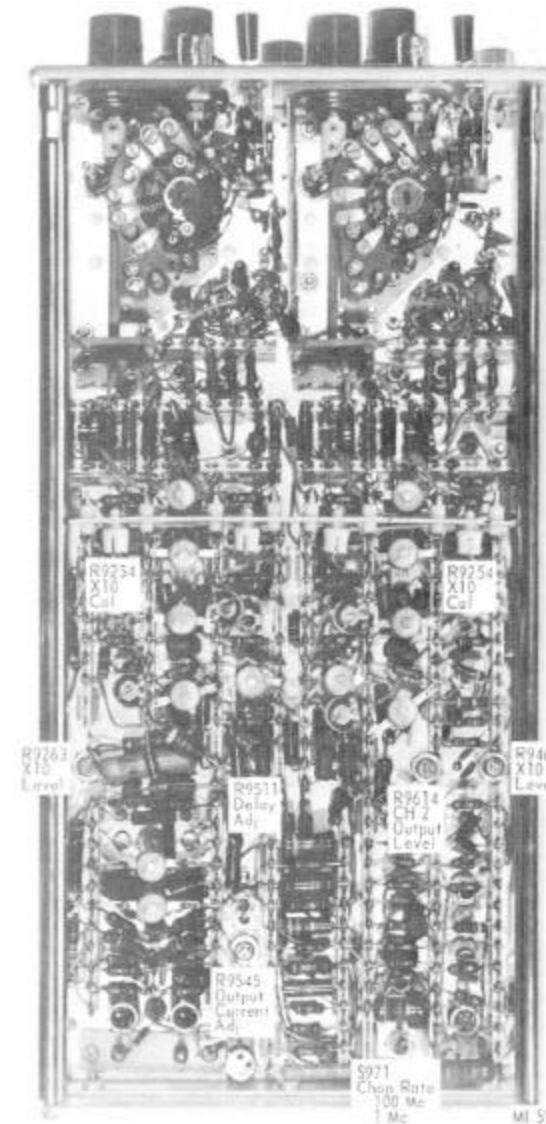

Figure 5-13.1. Bottom view of dual trace plug-in 79-02A showing controls.

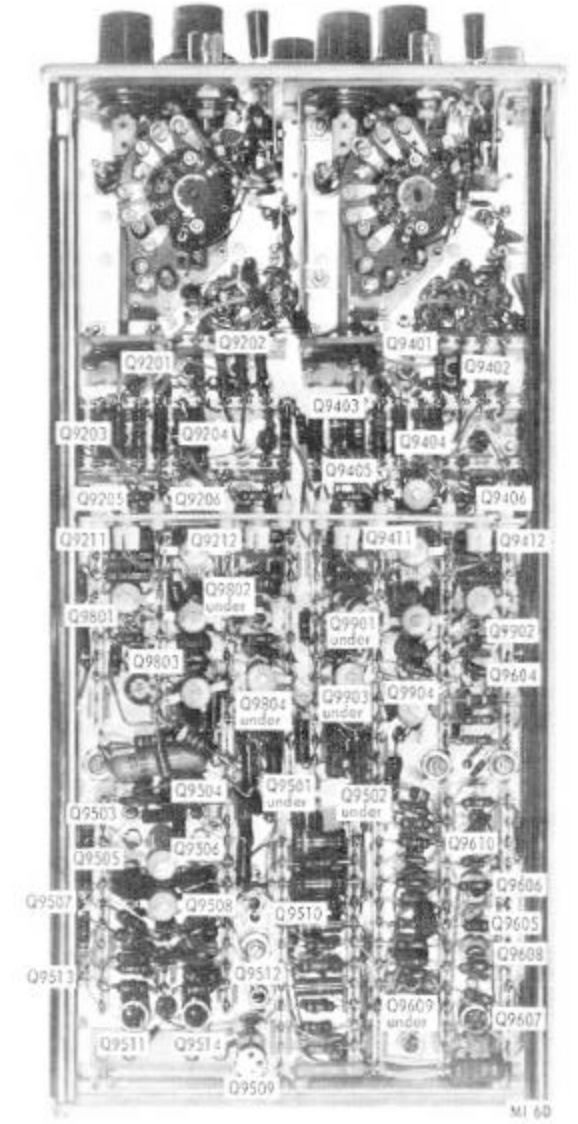

Figure 5-13.2. Bottom view of dual trace plug-in 79-02A showing transistors.

Section IV. CORRECTIVE MAINTENANCE

5-10. General

This section contains typical parts removal and replacement instructions that are within the scope of maintenance personnel.

5-11. Removal of the Main Frame and Plug-In Assemblies (Fig. 5-14)

Remove and install the carrying case and plug-in assemblies.

Note. When replacing the plug-in assembly, make sure the plug-in assembly connector guide pin is aligned with the main frame connector guide hole.

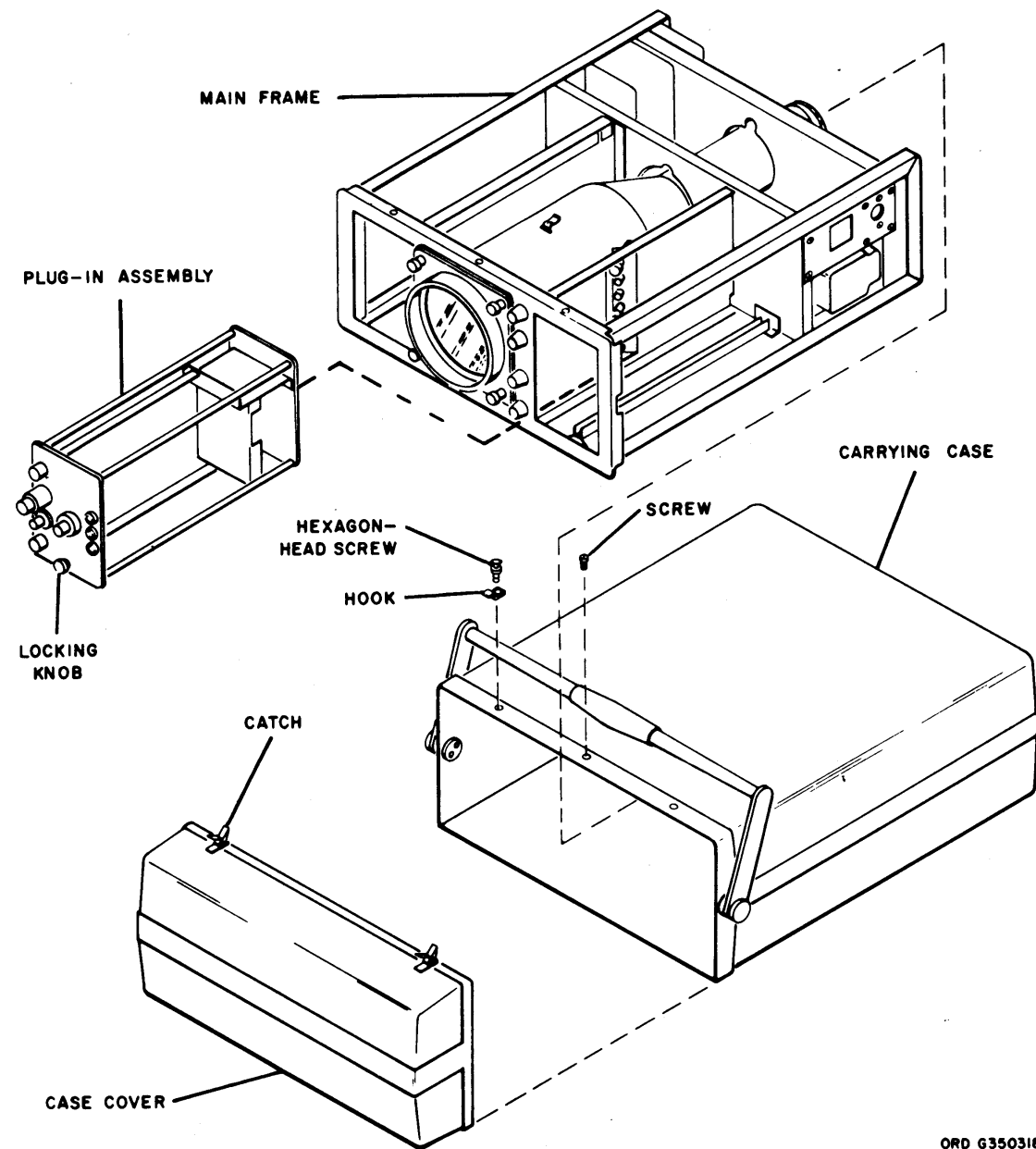

ORD G350318

Figure 5-14. Removal and installation of the main frame and plug-in assemblies.

5-12. Replacement of the CRT (Fig. 5-15)

Warning: A high voltage exists at the anode of the CRT. Deenergize the equipment before proceeding with replacement of the CRT.

Caution: Handle the CRT with great care to prevent breakage.

a. Removal.

- (1) Disconnect the tube socket (1) from the base of the CRT.
- (2) Disconnect the high-voltage cap (2) from the high-voltage anode connector on the CRT.
- (3) Disconnect the four leads (3) from the pins (4) that protrude from the neck of the CRT.

Note. Before disconnecting the leads, record their colors and the lugs to which they are connected.

- (4) Disconnect the ground lead (5) from the CRT shield (6).
- (5) Remove the four ring knobs and rubber washers (7 and 8) that fasten the ring front and graticule scale (9 and 10) to the oscilloscope front panel.
- (6) Remove the ring front and graticule scale.
- (7) Loosen the clamp (11) at the neck of the CRT.
- (8) Remove the CRT by slowly pulling it out of the CRT shield and through the opening in the front panel.

Caution: Be careful not to damage the four pins that protrude from the neck of the CRT.

b. Installation.

- (1) Insert the CRT through the opening in the front panel and into the CRT shield, making sure the CRT high-voltage anode connector is on the same side as the high-voltage cap.
- (2) Connect the tube socket, high-voltage cap, ground lead, and the four leads to their proper locations.
- (3) Tighten the clamp at the neck of the CRT.
- (4) Install the graticule scale and ring front.

Note. After the tube is installed, it may be necessary to align the trace to the graticule scale.

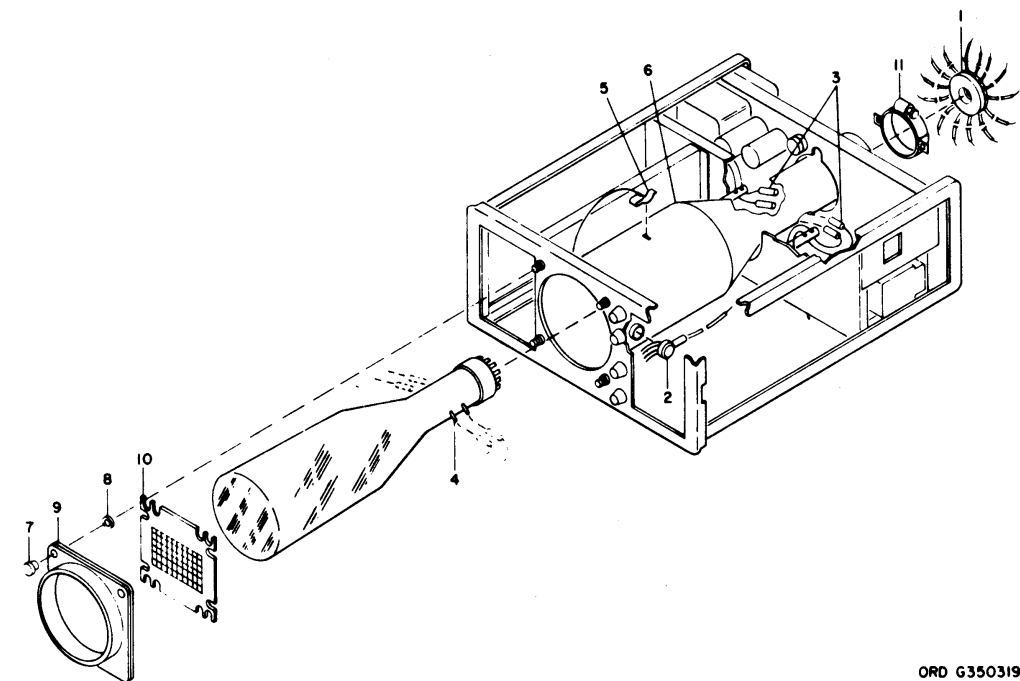

ORD G350319

Figure 5-15. Replacement of the CRT.

5-13. Replacement of the Fan Assembly (Fig. 5-16)

a. Removal.

- (1) Unsolder the two hookup leads (1) connected to the solder lugs (2) on the fan assembly (3).

Note. Before disconnecting the leads, record their colors and the lugs to which they are connected.

- (2) Loosen the mounting plate (4) from the main frame (5) by removing the three plate mounting screws (6).
- (3) Remove the two mounting screws, lockwashers, and the two nuts (7, 8, and 9) that fasten the fan assembly to the main frame. (Be careful not to drop the washers and nuts within the main frame.)
- (4) Ease the fan assembly (3) out of the main frame and remove the two screws, washers and nuts (10, 11 and 12) that hold the mounting plate to the fan assembly.
- (5) Remove the four screws, standoffs, lockwashers and nuts (13 through 16) that mount the fan screen (17) to the fan assembly.

b. Installation. Using the reverse procedure of *a* above, mount the fan screen to the fan assembly; connect the mounting plate to the fan assembly; and install the fan within the main frame. Solder the two leads to the fan assembly lugs.

Note. The fan, when on, should blow air outwards (exhaust type) from the main frame. If the two leads have been interchanged, while being connected, the fan will blow air into the main frame. To correct this, unsolder the two leads, reverse and reconnect them.

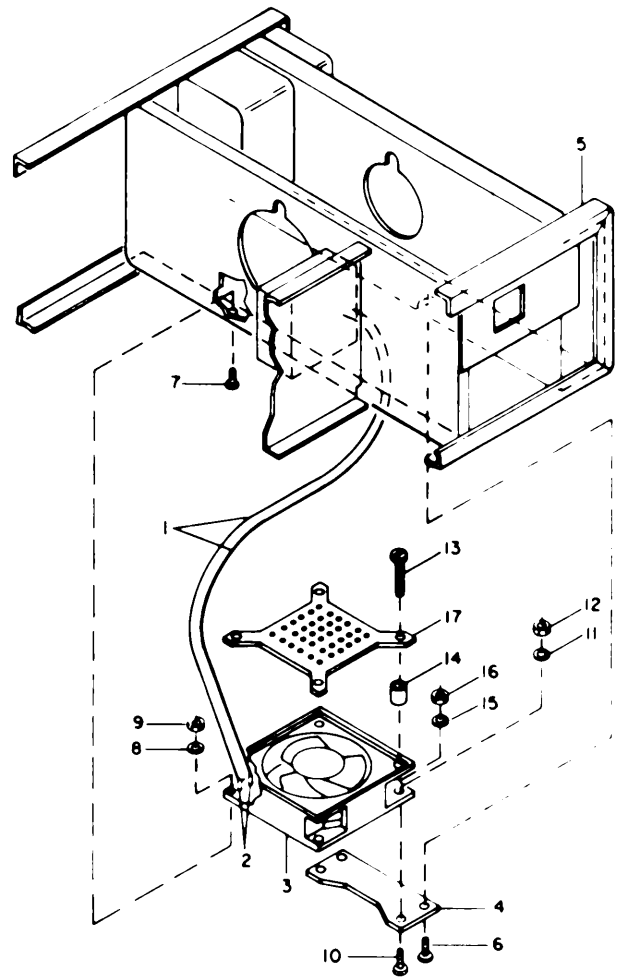

ORD G350320

Figure 5-16. Replacement of the fan assembly.

CHAPTER 6
SCHEMATICS

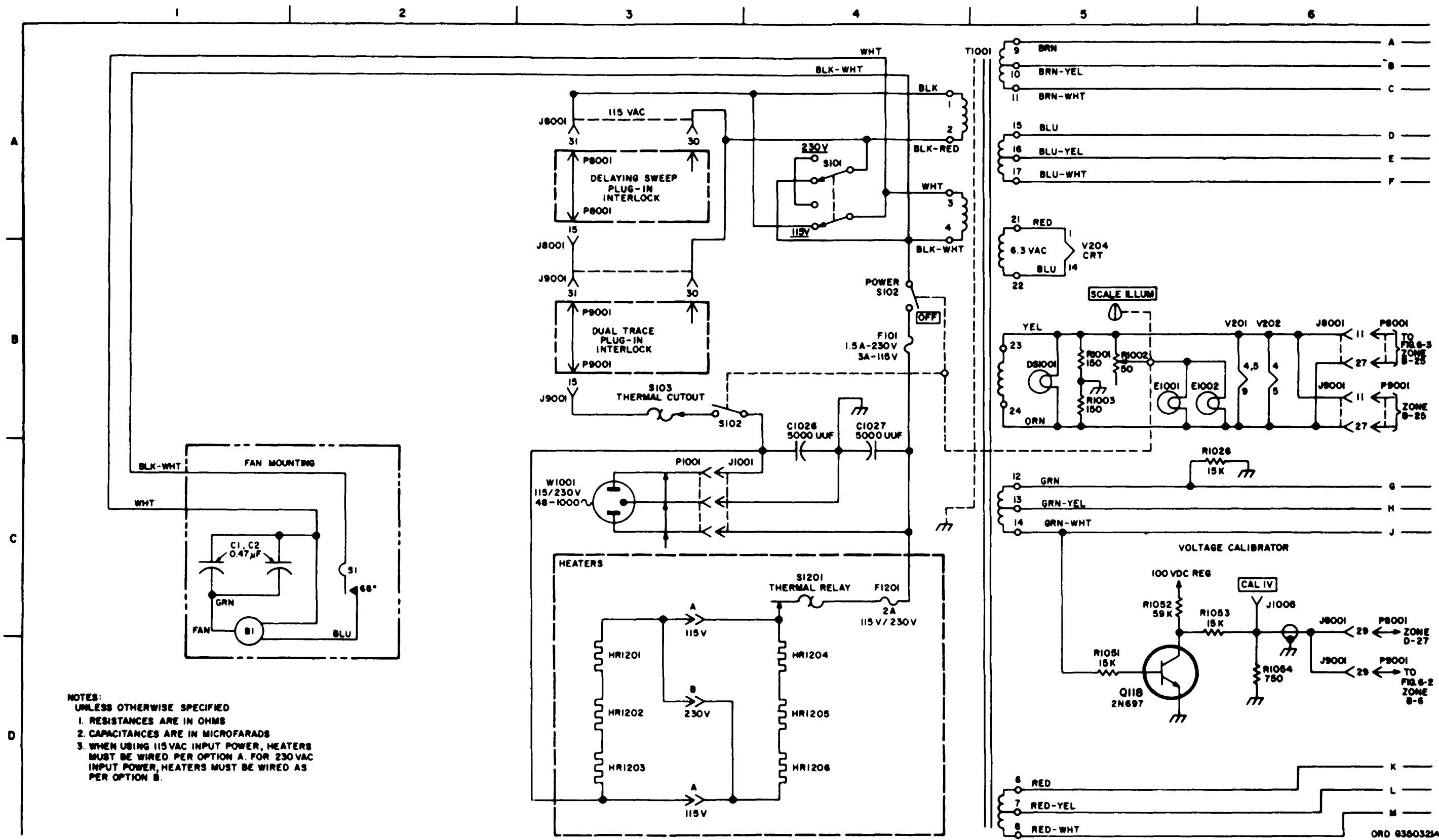

NOTES:
UNLESS OTHERWISE SPECIFIED
1. RESISTANCES ARE IN OHMS
2. CAPACITANCES ARE IN MICROFARADS
3. WHEN USING 115 VAC INPUT POWER, HEATERS MUST BE WIRED PER OPTION A. FOR 230VAC INPUT POWER, HEATERS MUST BE WIRED AS PER OPTION B.

Figure 6-1. Main frame, oscilloscope 765MH with mod 116, schematic (sheet 1 of 5)

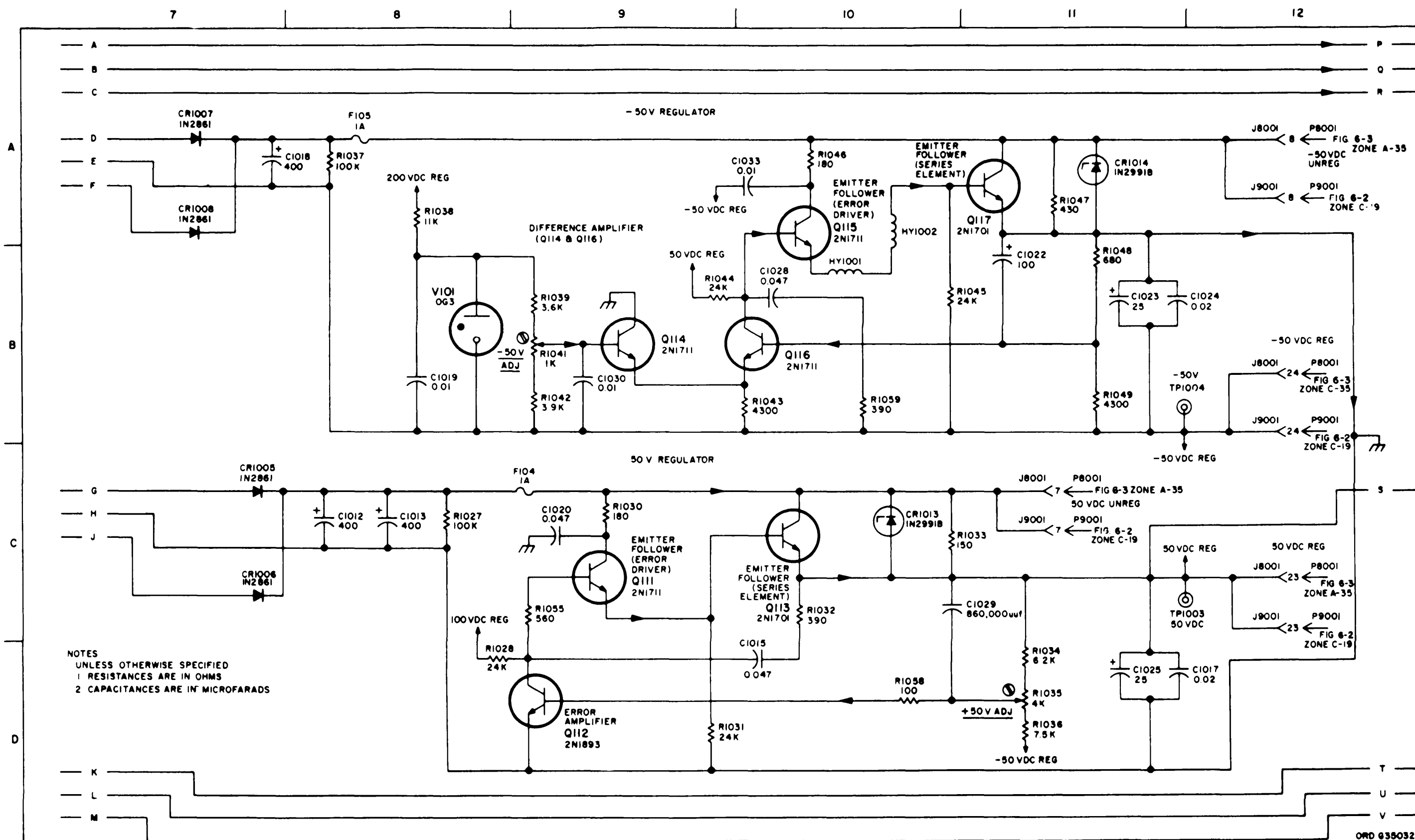

Figure 6-1. Main frame, oscilloscope 765MH with mod 116, schematic (sheet 2 of 5)

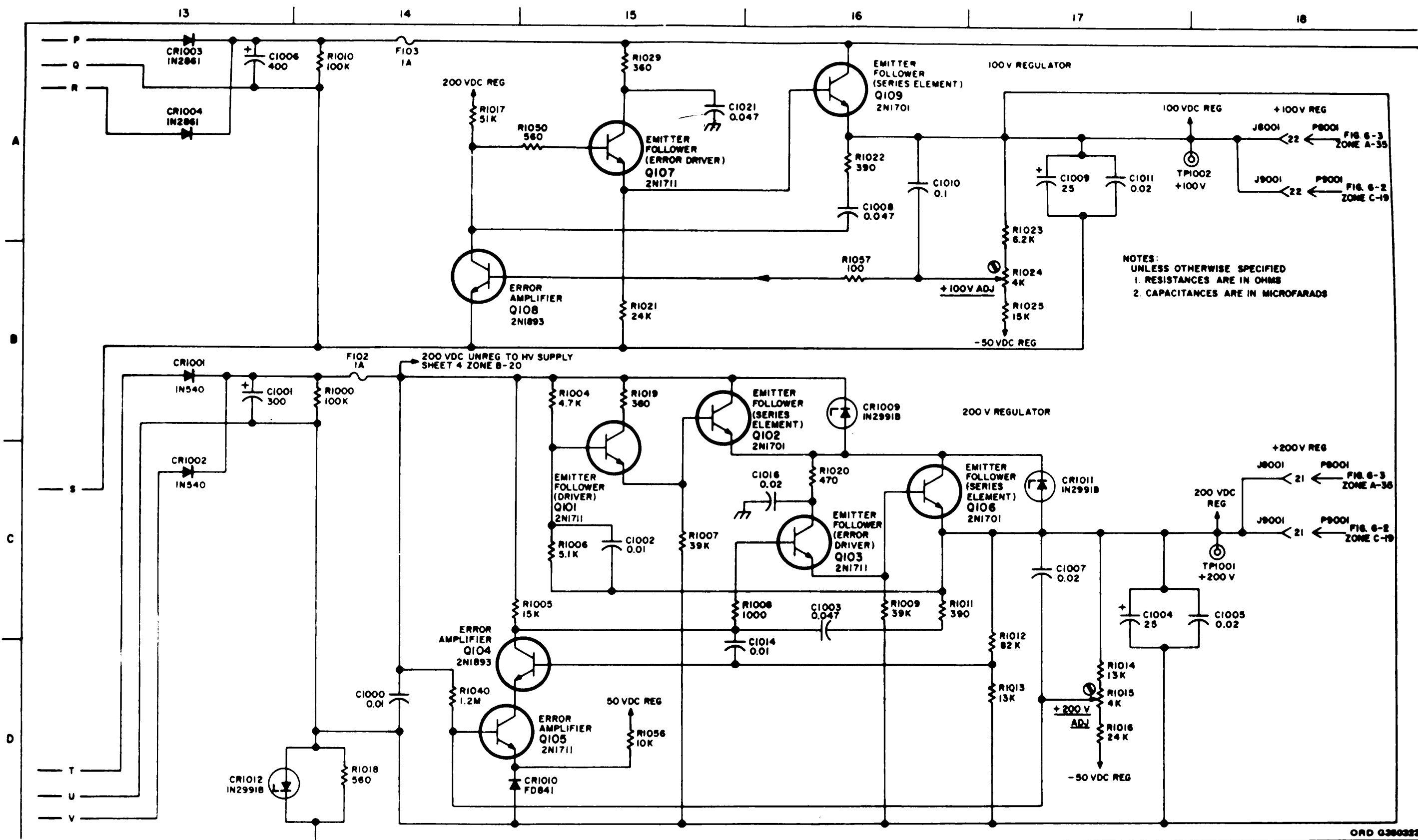

Figure 6-1. Main frame, oscilloscope 765MH with mod 116, schematic (sheet 3 of 5)

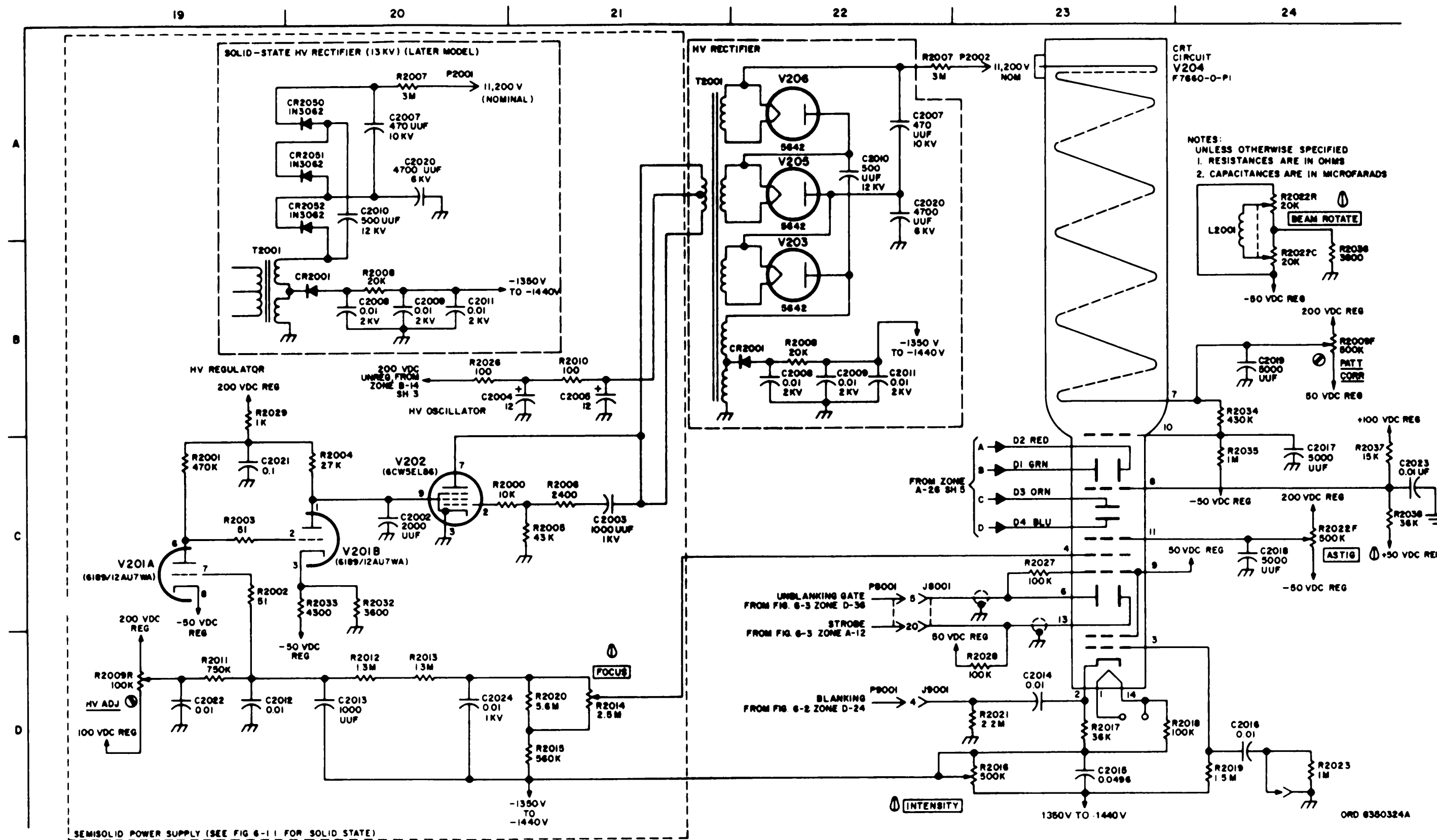

Figure 6-1. Main frame, oscilloscope 765MH with mod 116, schematic (sheet 4 of 6)

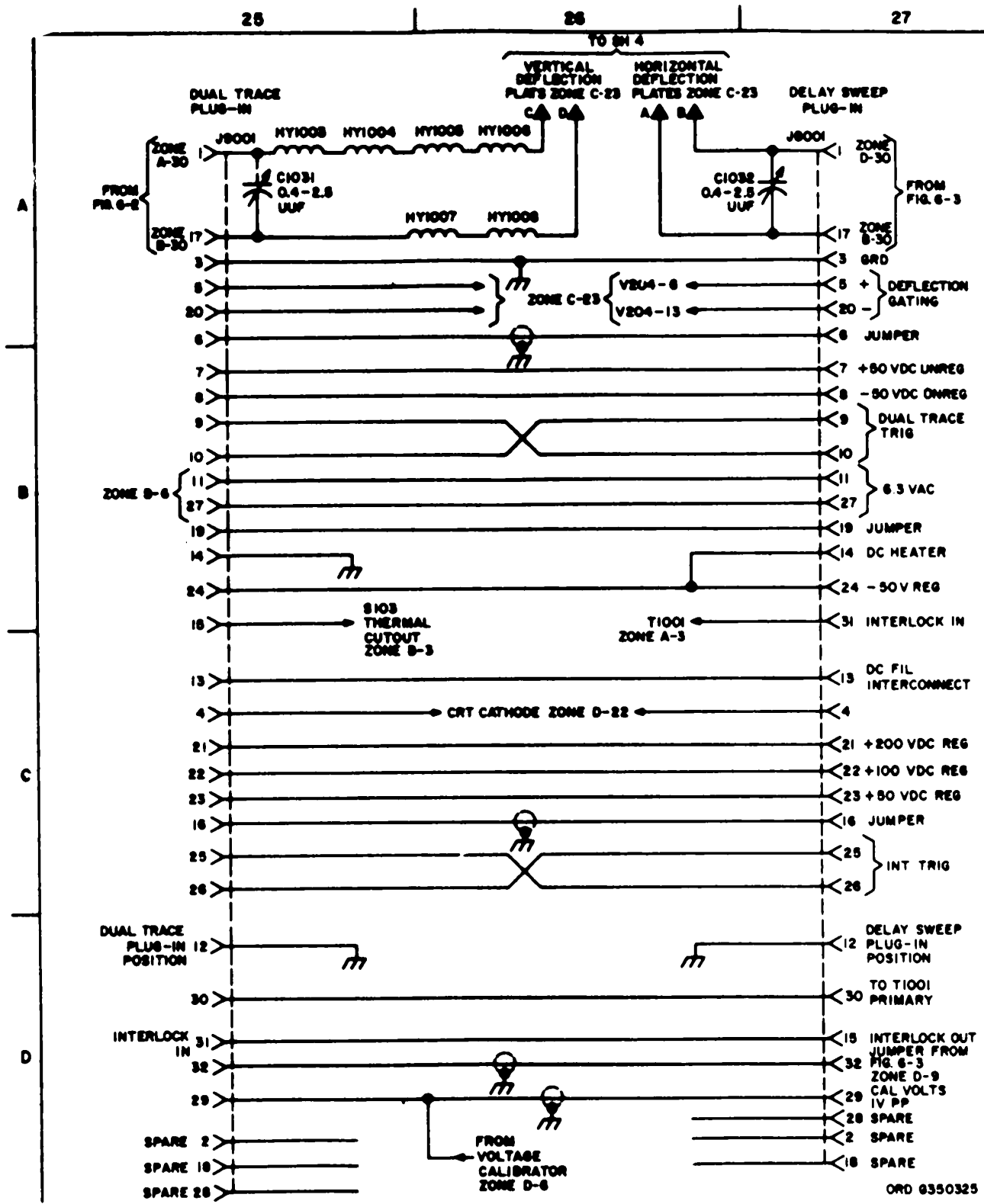

Figure 6-1. Main frame, oscilloscope 765MH with mod 116, schematic (sheet 5 of 5)

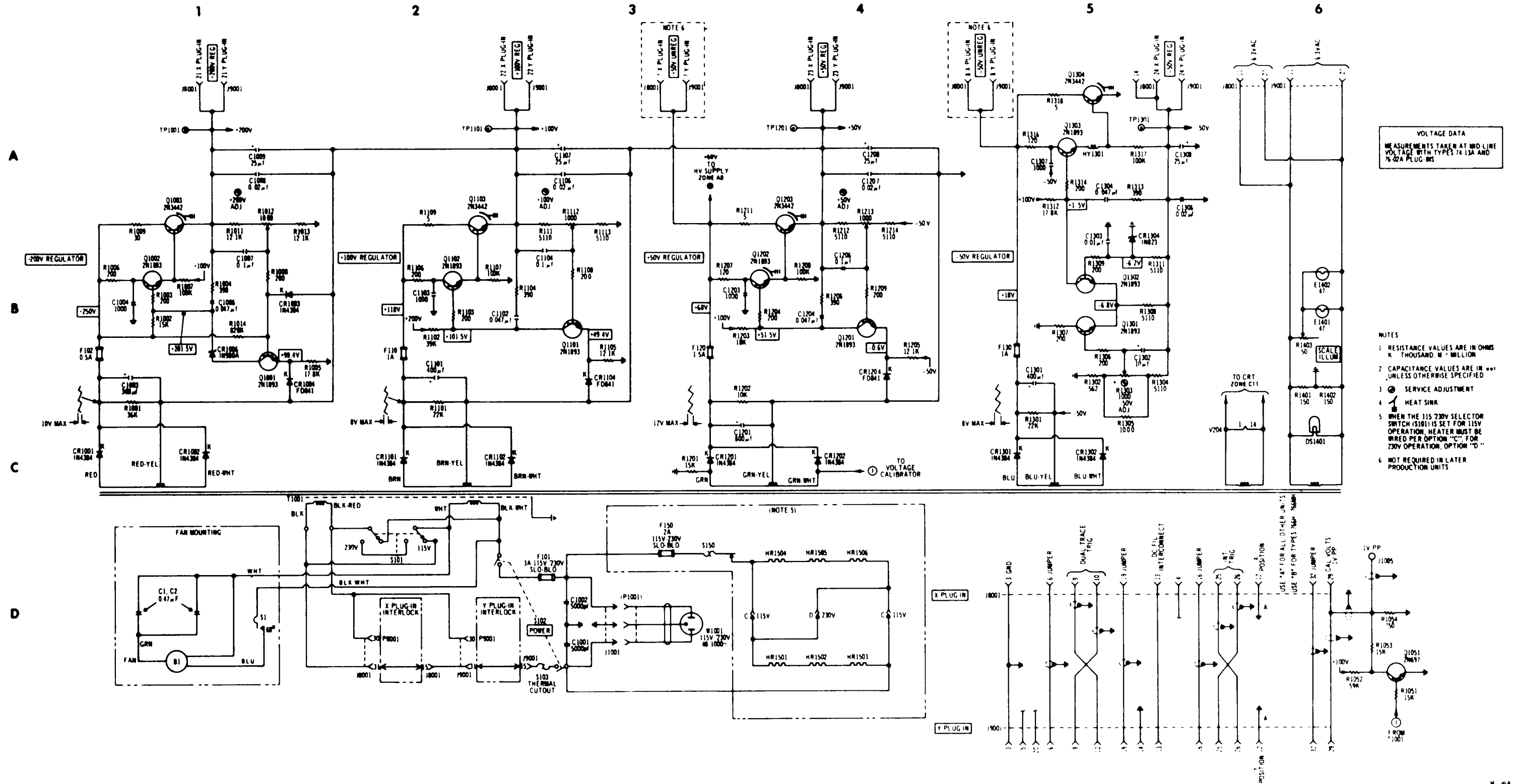

Figure 6-1.1. Main frame; low voltage power supplies, 765MH (newer), 765MH/F and 765MA, schematic.

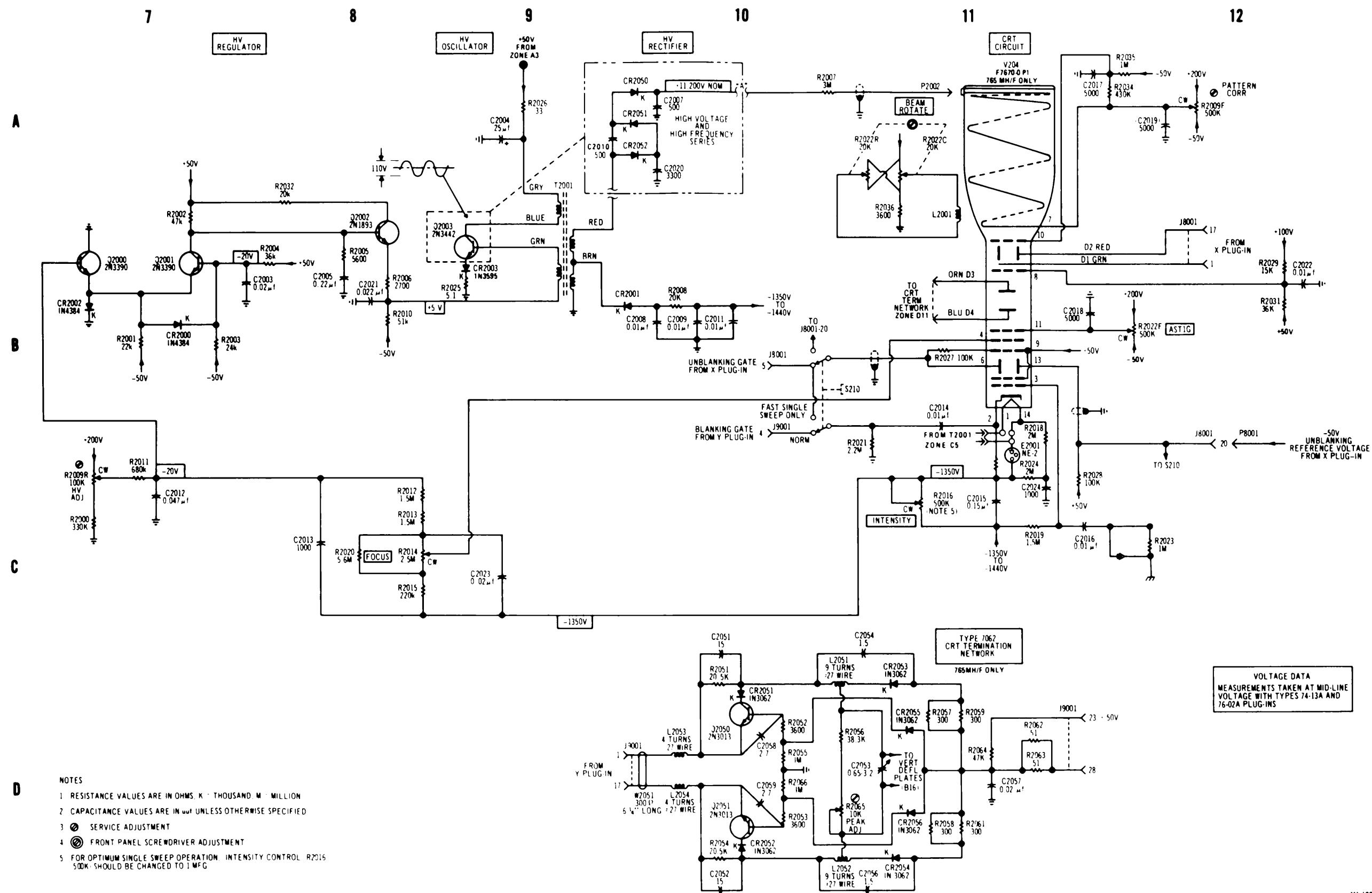

Figure 6-1.2. Main frame; CRT and high voltage circuits, 765MH (newer) and 765MH/F, schematic.

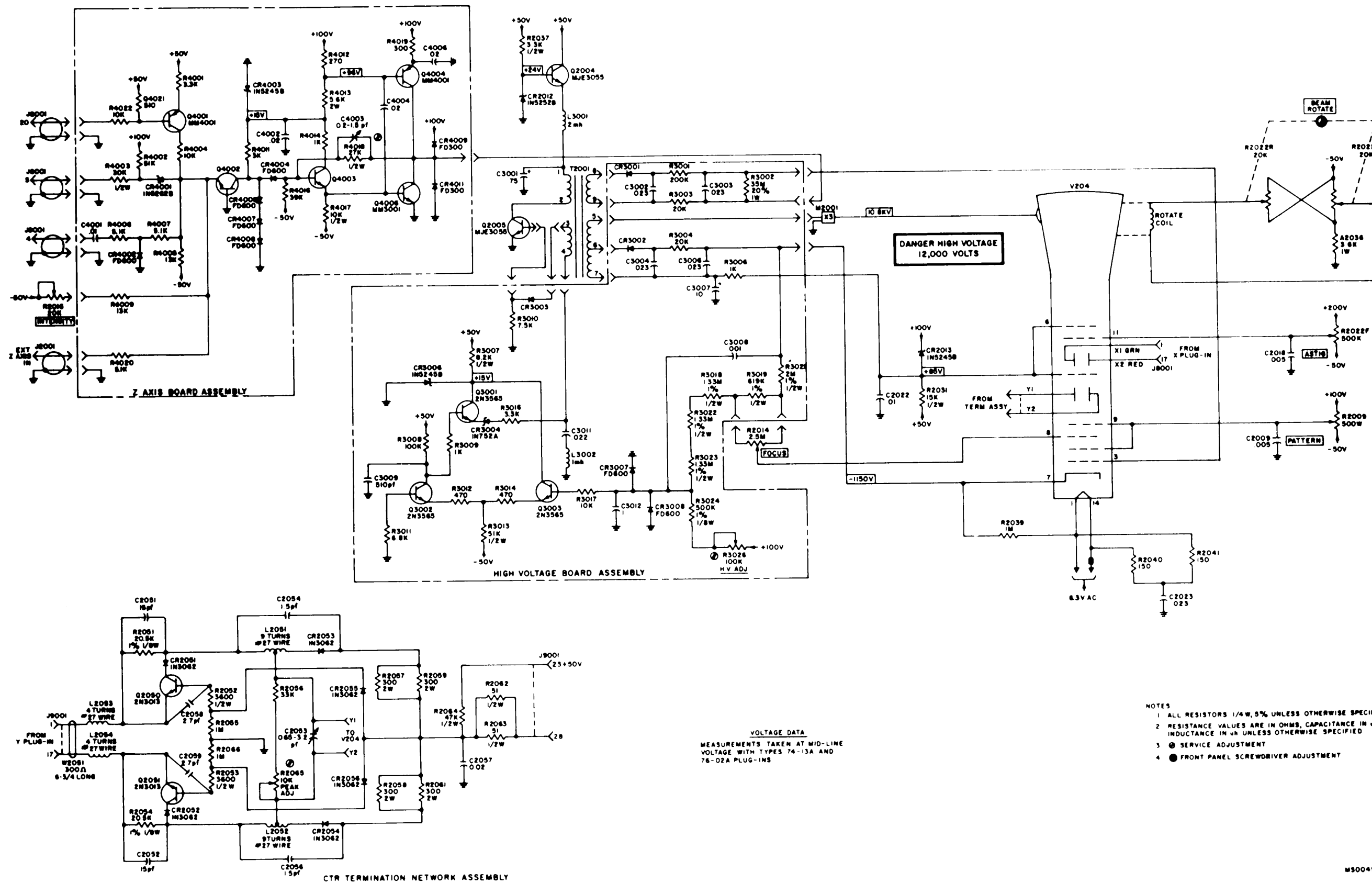

Figure 6-1.3. Main frame; CRT and high voltage circuits, 765MA, schematic.

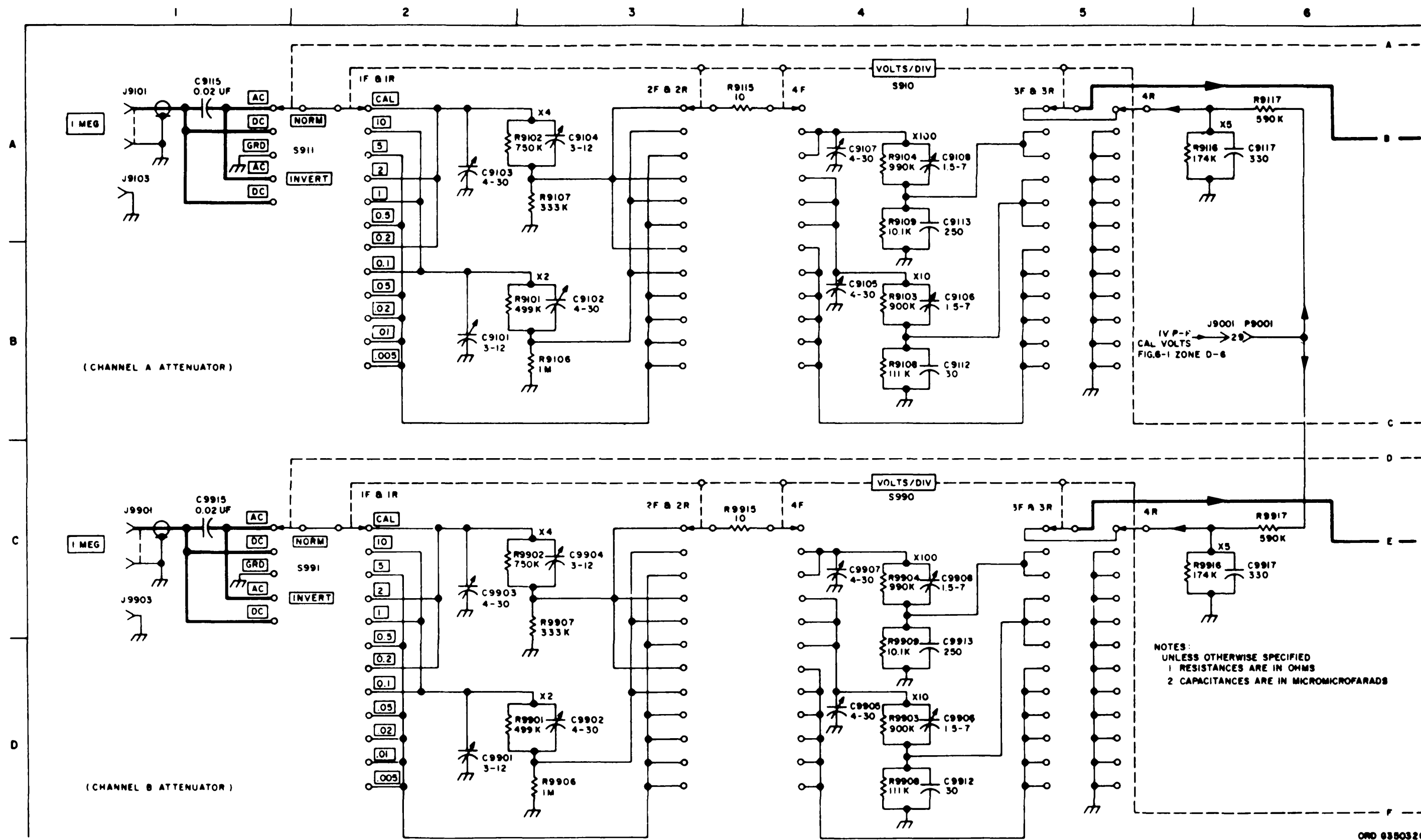

Figure 6-2. Dual trace plug-in (type 76-02A with mod 101 and delay line), schematic (sheet 1 of 5)

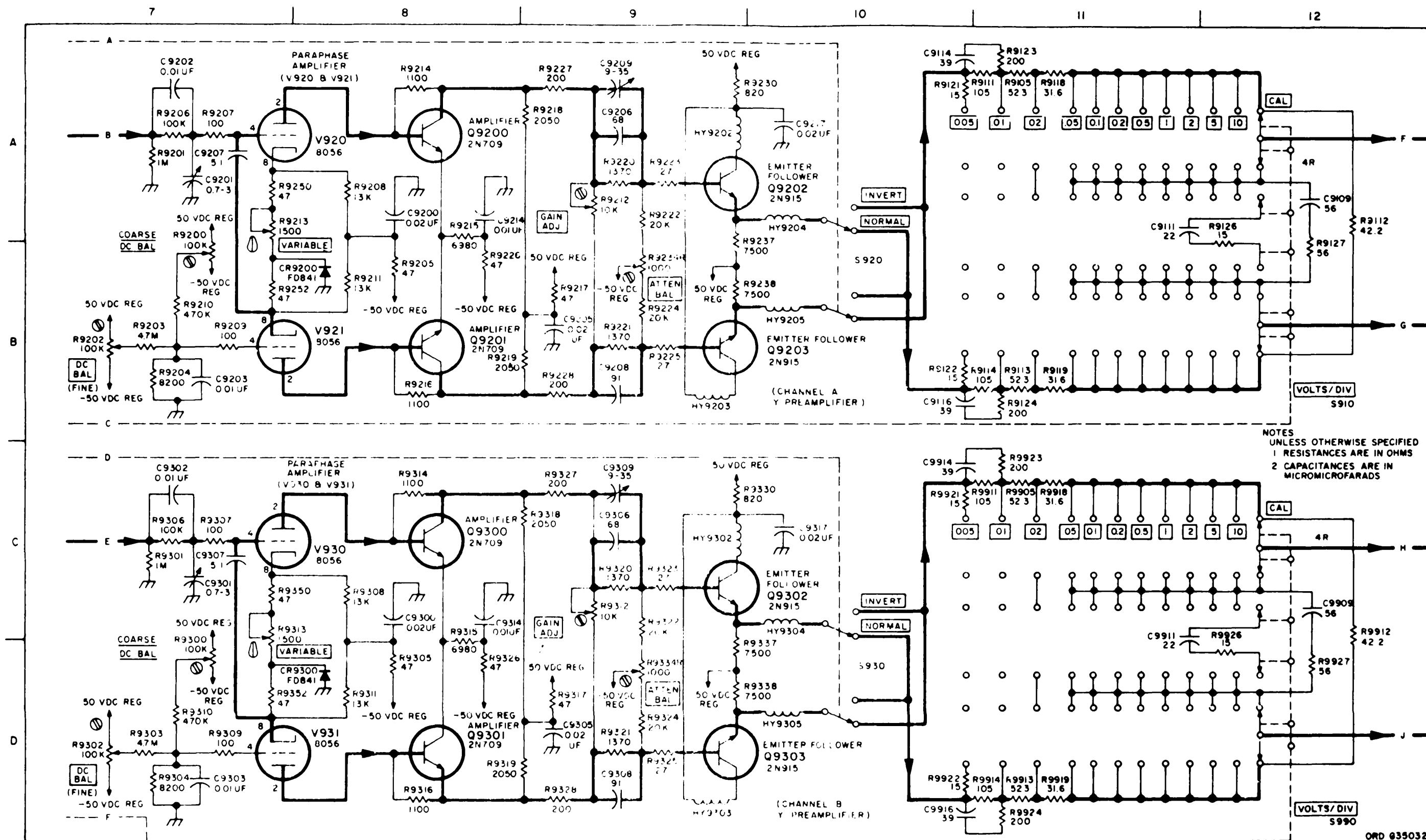

Figure 6-2. Dual trace plug-in (type 76-02A with mode 101 and delay line), schematic (sheet 2 of 5)

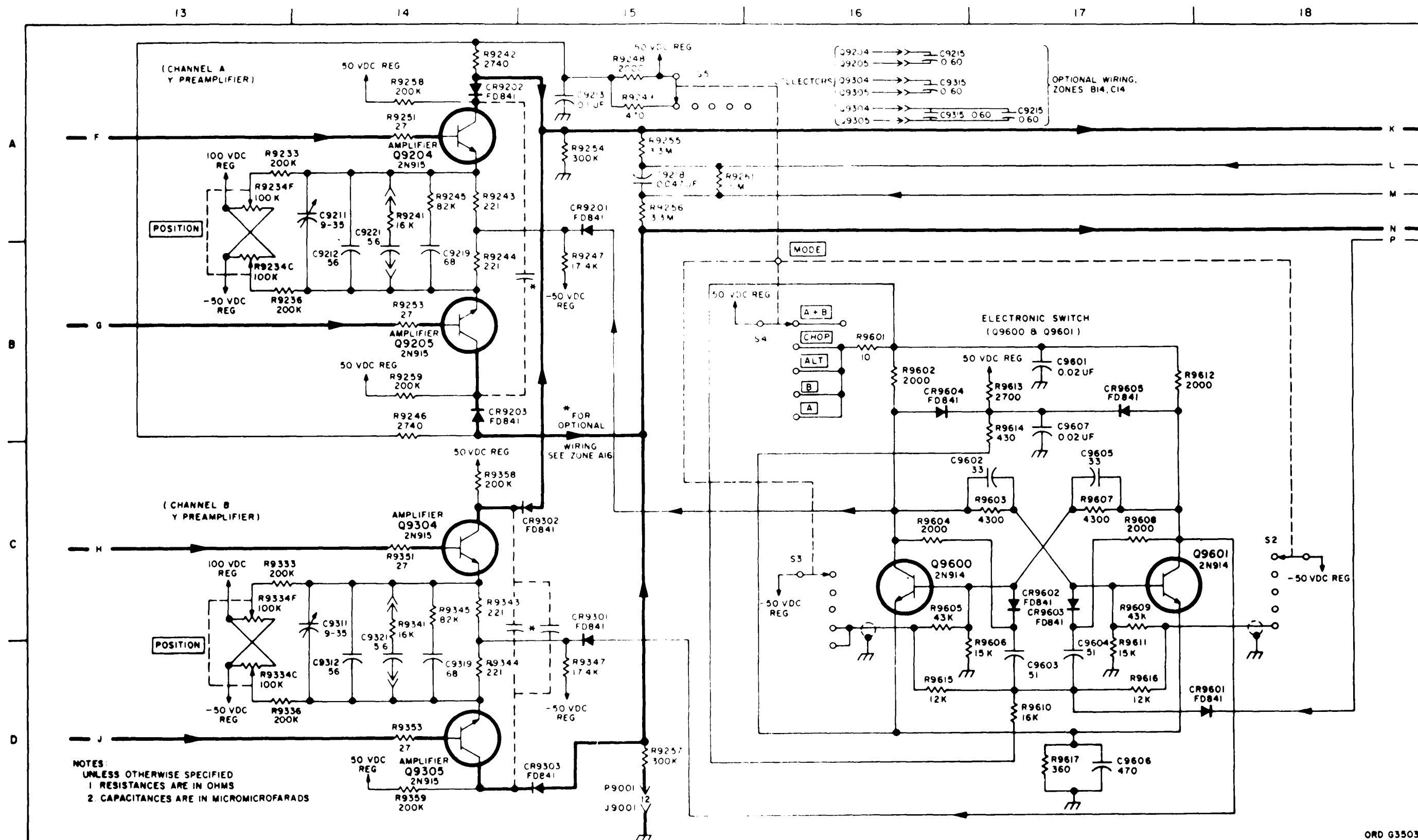

Figure 6-2. Dual trace plug-in (type 76-02A with mod 101 and delay line), schematic (sheet 3 of 5)

ORD G350328A

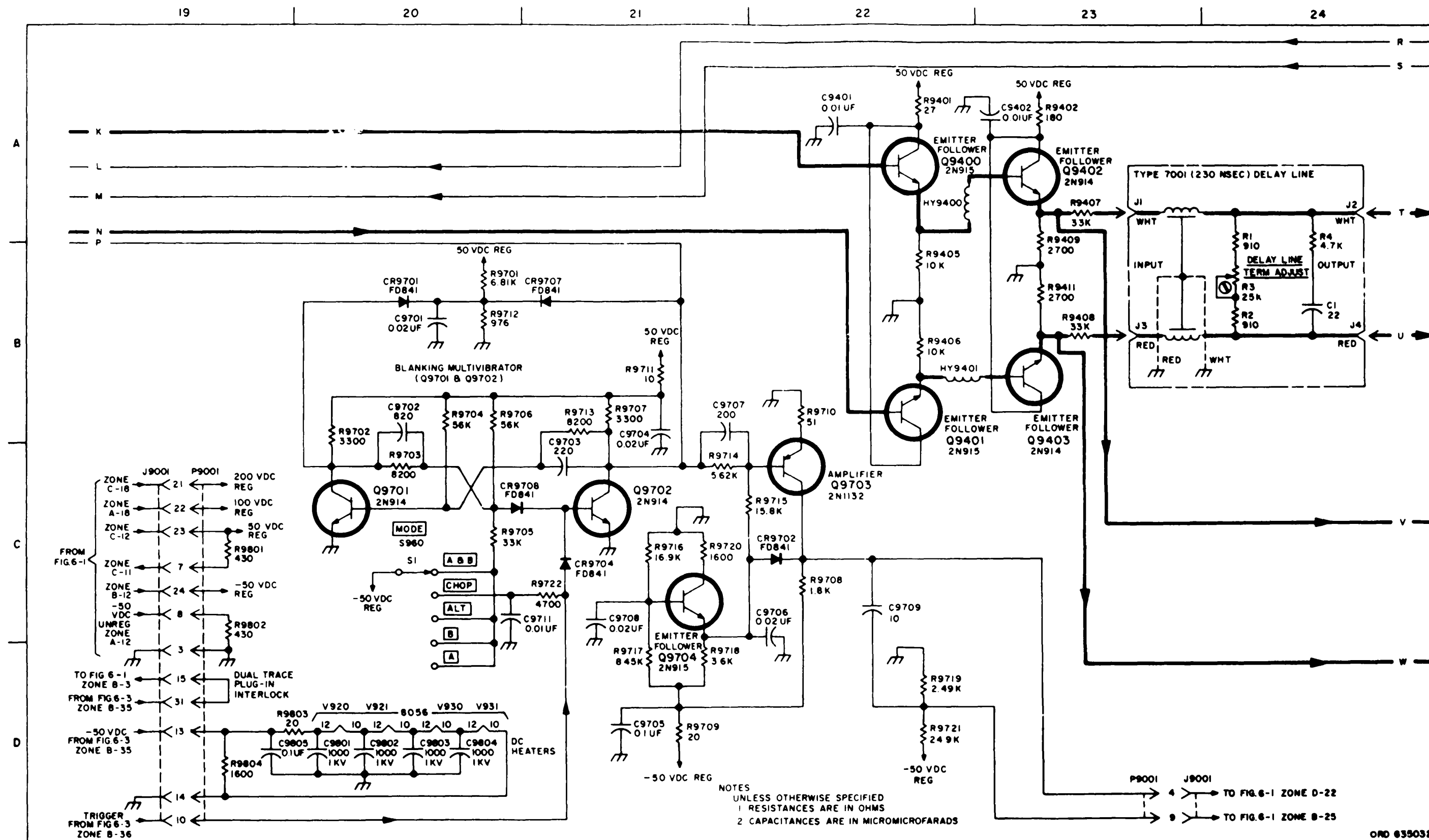
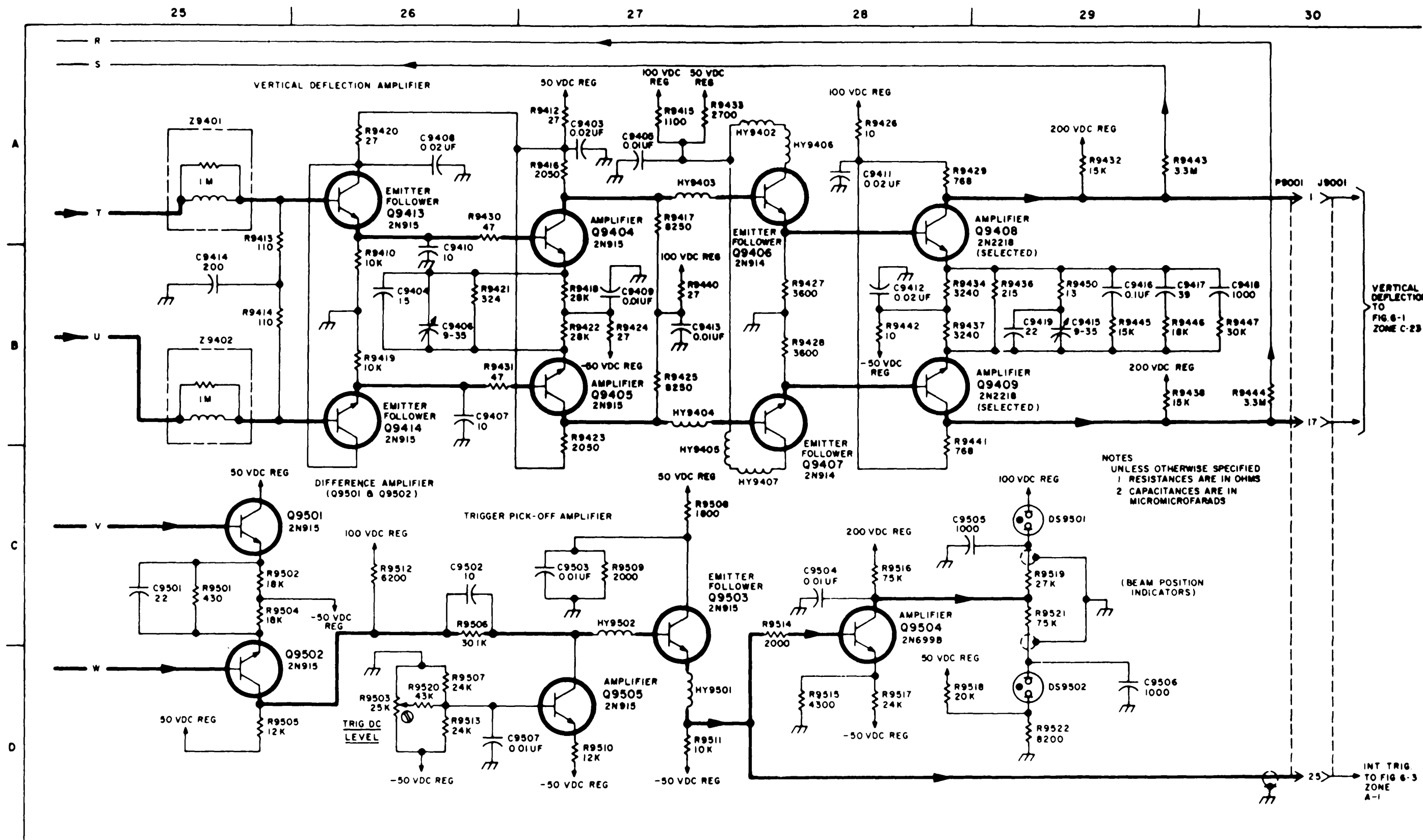

Figure 6-2. Dual trace plug-in (type 76-02A with mod 101 and delay line), schematic (sheet 4 of 5)



ORD 0350330

Figure 6-2. Dual trace plug-in (type 76-02A with mod 101 and delay line), schematic (sheet 5 of 5)

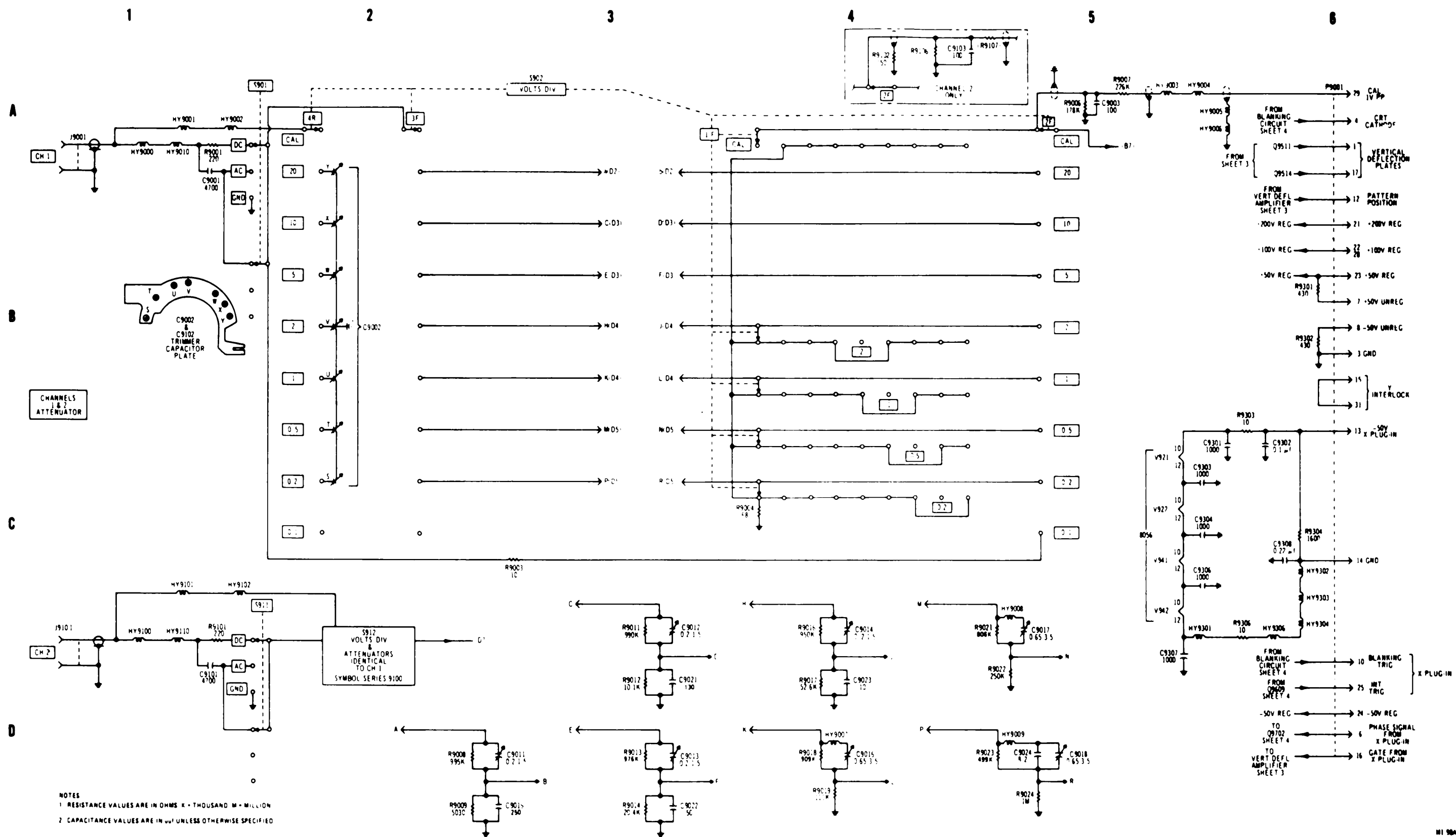

Figure 6-2.1. Dual trace plug-in (type 79-02A with mode 103 and delay line), schematic (sheet 1 of 4)

7

8

9

10

11

12

VOLTAGE DATA

1. ALL VOLTAGE MEASUREMENTS WERE OBTAINED WITH A 70 OHM VOLT VOM. ALL READINGS ARE IN VOLTS.
2. PRESET FRONT-PANEL CONTROLS AS FOLLOWS:

CONTROL	SETTING
MODE	CH 1
VARIABLE	FULLY CW
POSITION	CENTERED
INPUT SELECTOR	CAD (BOTH CHANNELS)

3. VOLTAGE TOLERANCE - 1% WITH RESPECT TO GROUND.

WAVEFORM DATA

4. USE TYPE 7988 PROBE (X10)
5. USE TYPE 7988 F SERIES OSCILLOSCOPE. DC TO 100 MC WITH MODE SWITCH SET TO CHOP.
6. WAVEFORM AMPLITUDE MEASUREMENTS ARE NOMINAL.

- NOTES**
1. RESISTANCE VALUES ARE IN OHMS R = THOUSAND Ω = MILLIΩ
 2. CAPACITANCE VALUES ARE IN μF UNLESS OTHERWISE SPECIFIED
 3. ● SERVICE ADJUSTMENT
 4. ● FRONT PANEL SCREW DRIVER ADJUSTMENT
 5. ▽ HEAT SINK
 6. ○ COMMON CONNECTION

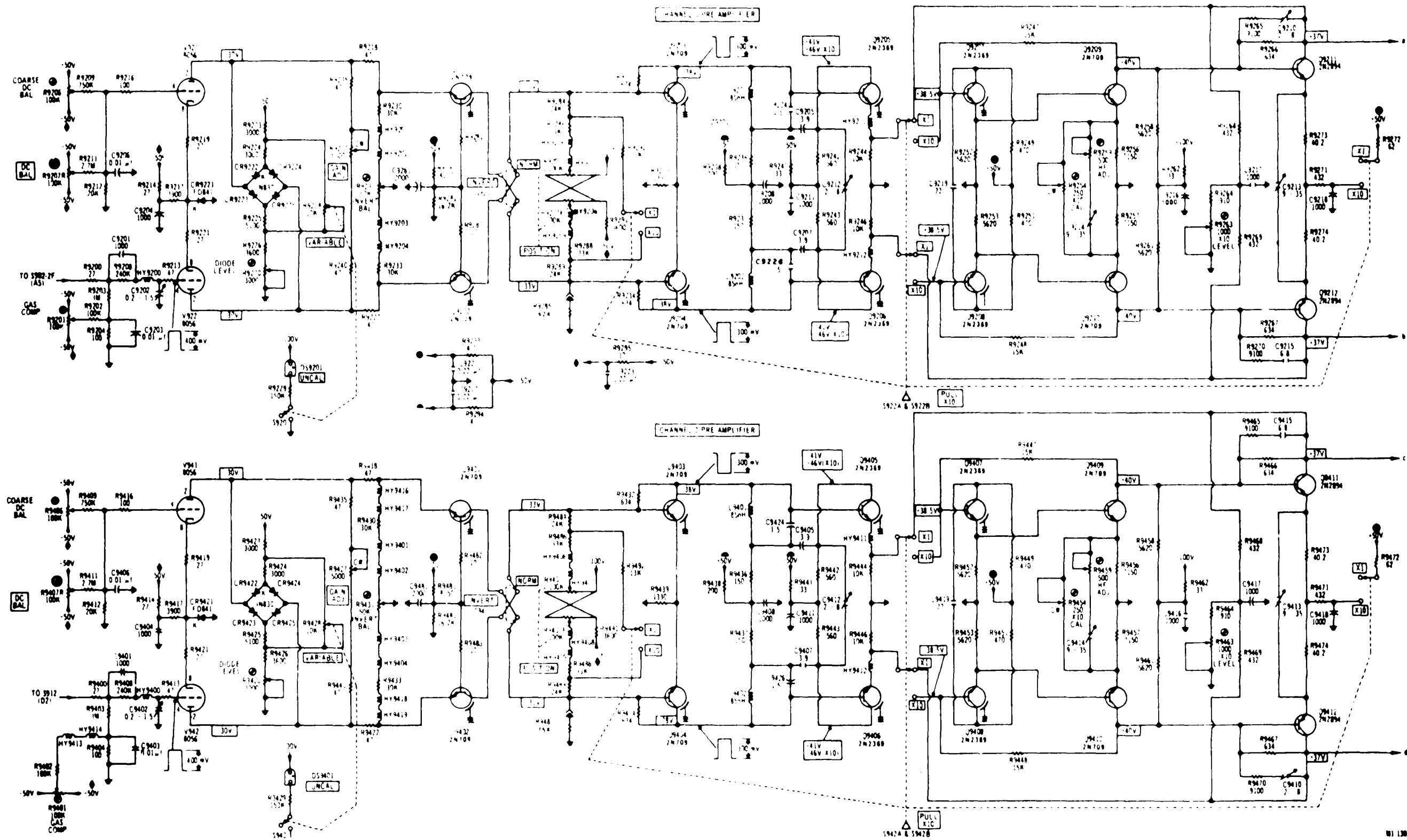

Figure 6-2.1. Dual trace plug-in (type 79-02A with mod 103 and delay line), schematic (sheet 2 of 4)

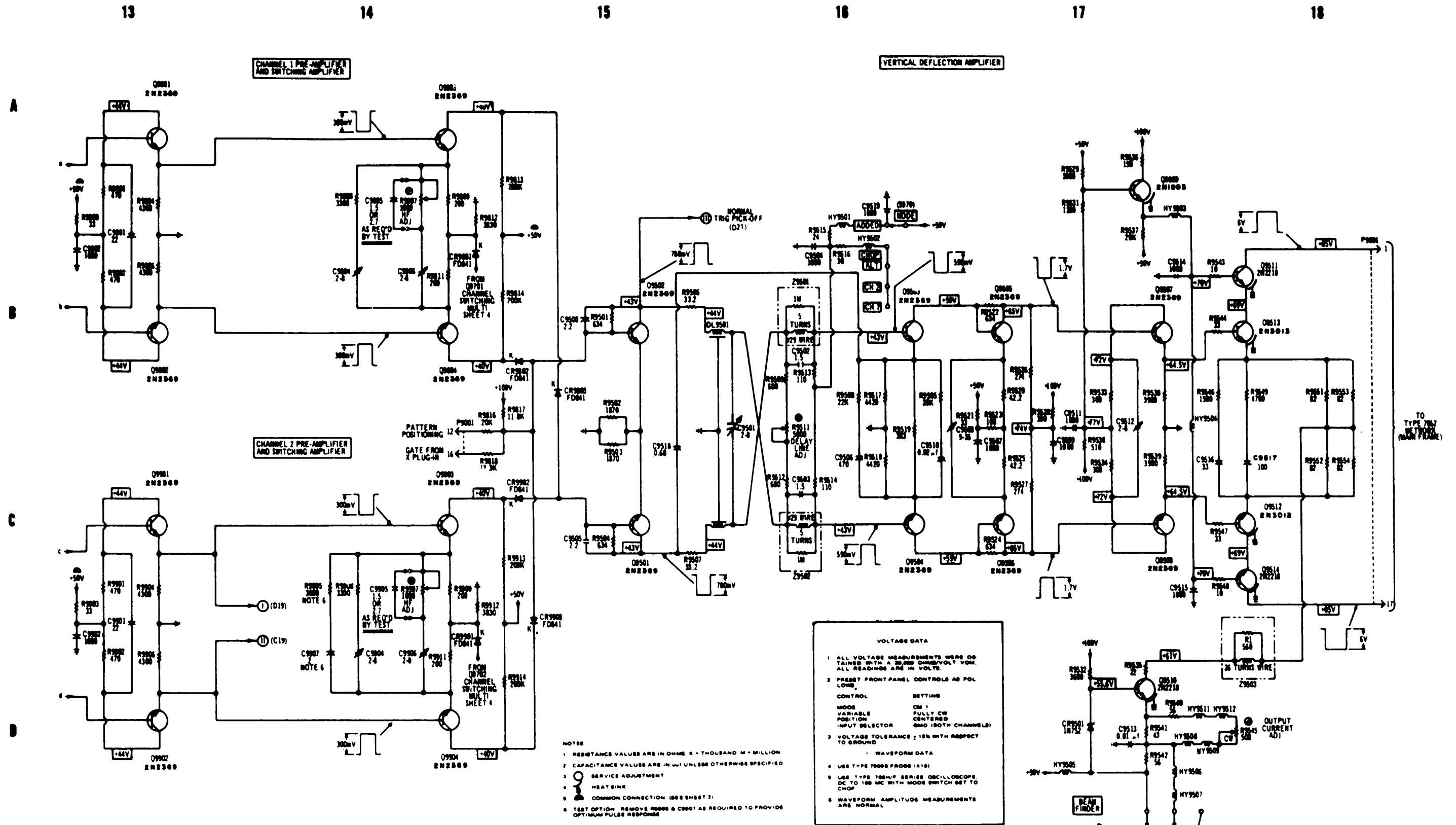

Figure 6-2.1. Dual trace plug-in (type 79-02A with mod 103 and delay line), schematic (sheet 3 of 4)

19

20

21

22

23

24

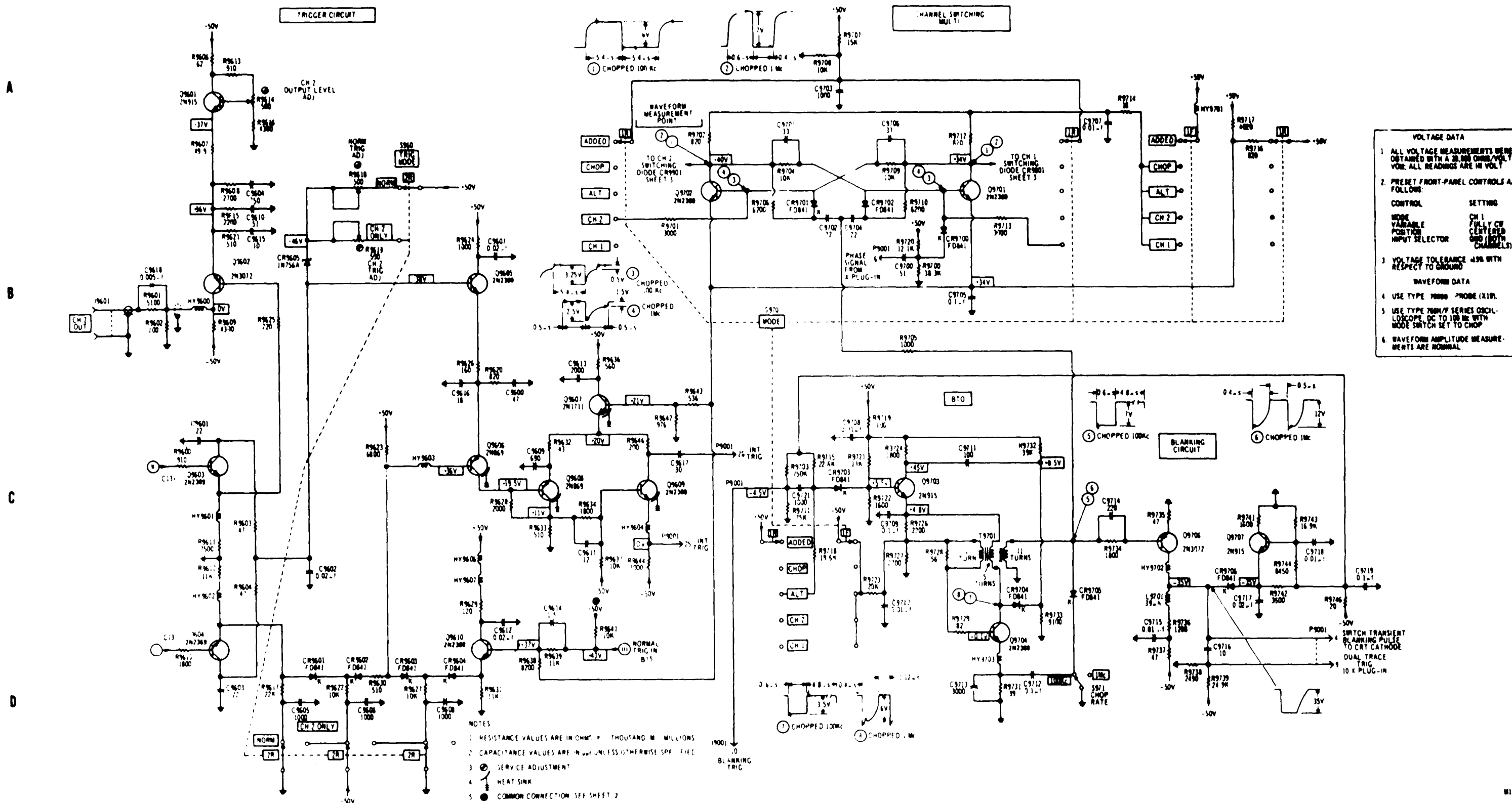

Figure 6-2.1. Dual trace plug-in (type 79-02A with mod 103 and delay line), schematic (sheet 4 of 4)

MI 91A

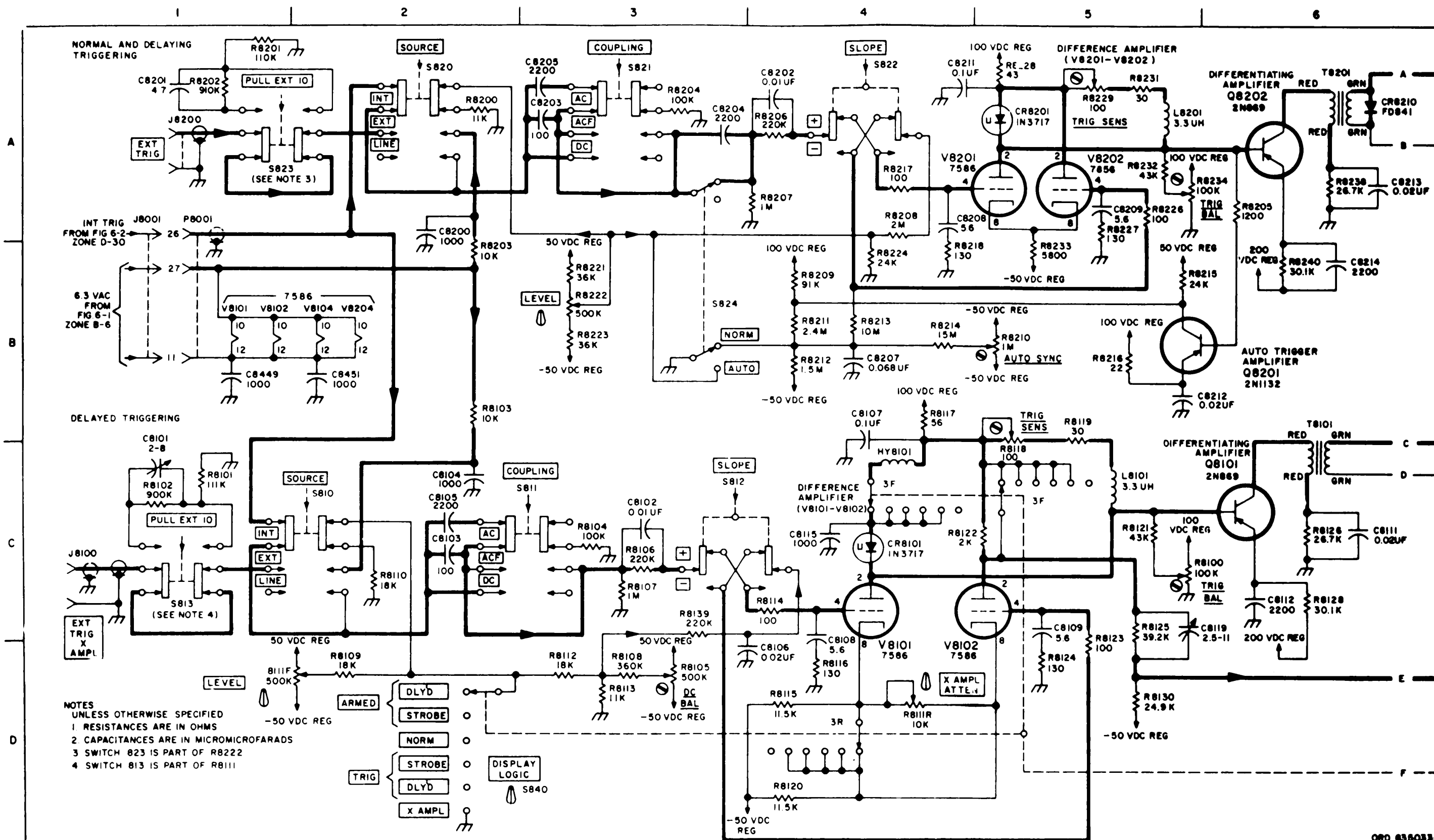

Figure 6-3. Delaying sweep plug-in, older version (type 74-13A with mod 101), schematic (sheet 1 of 6)

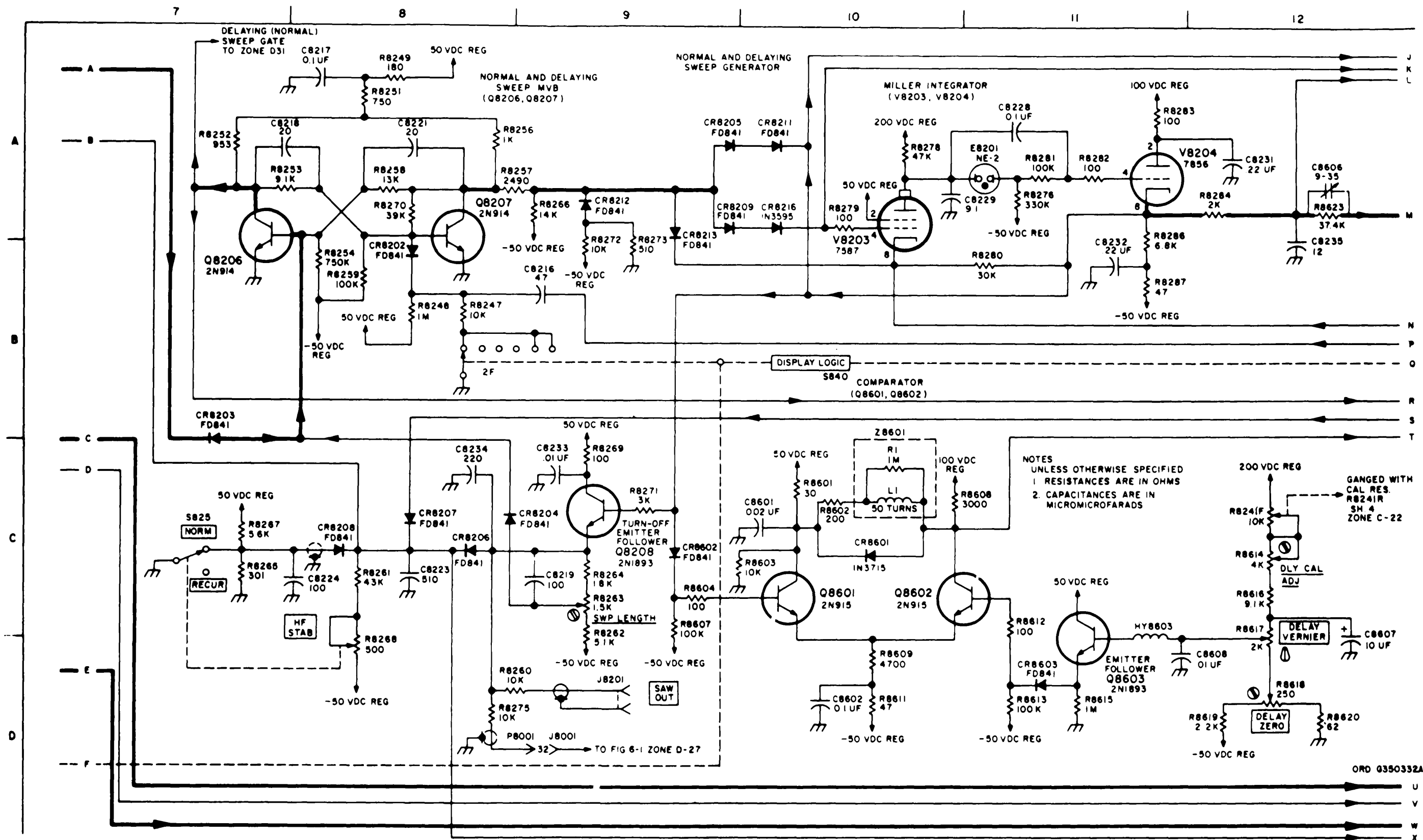

Figure 6-3. Delaying sweep plug-in, older version (type 74-13A with mod 101), schematic (sheet 2 of 6)

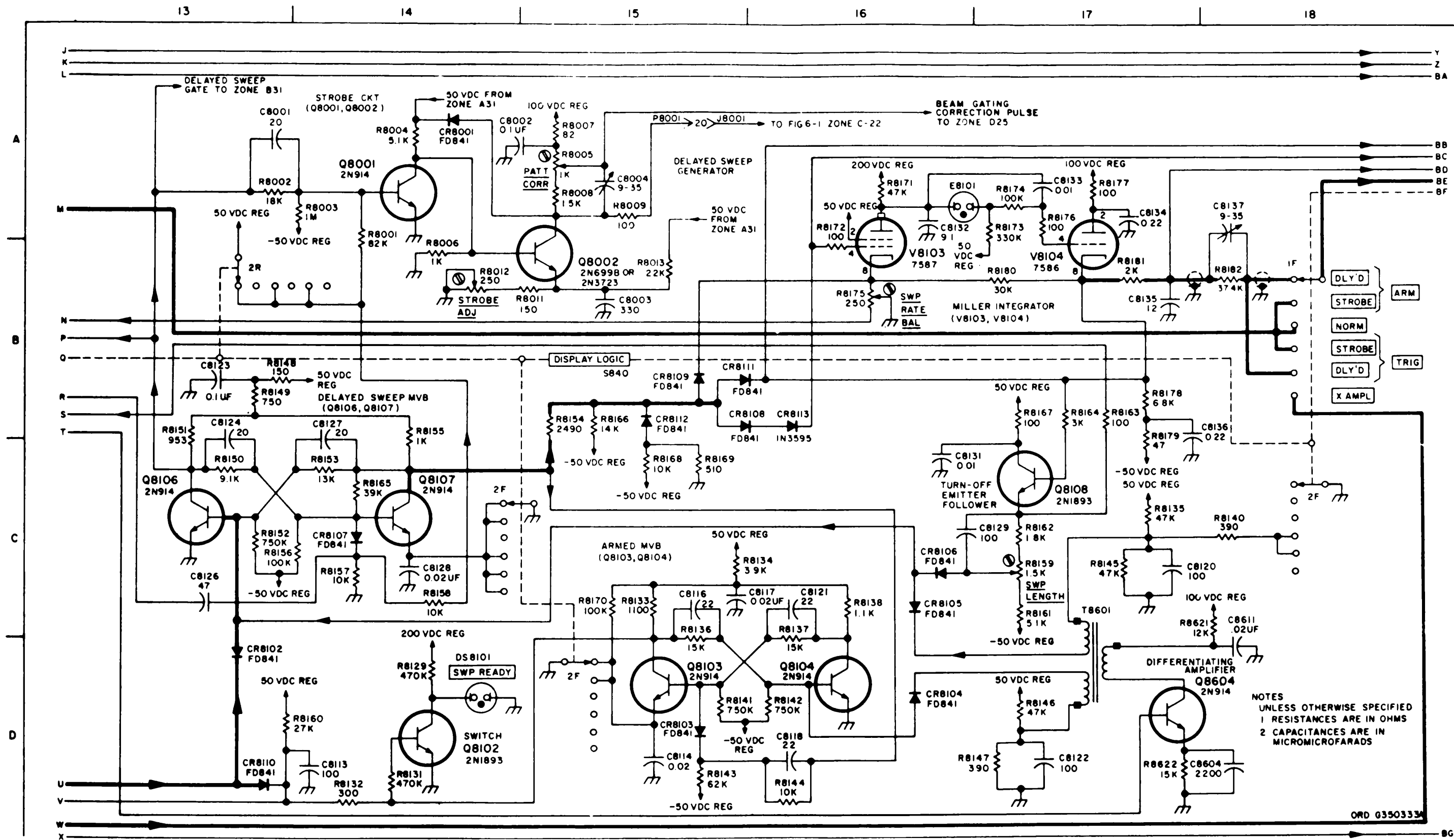

Figure 6-3. Delaying sweep plug-in, older version (type 74-13A with mod 101), schematic (sheet 3 of 6)

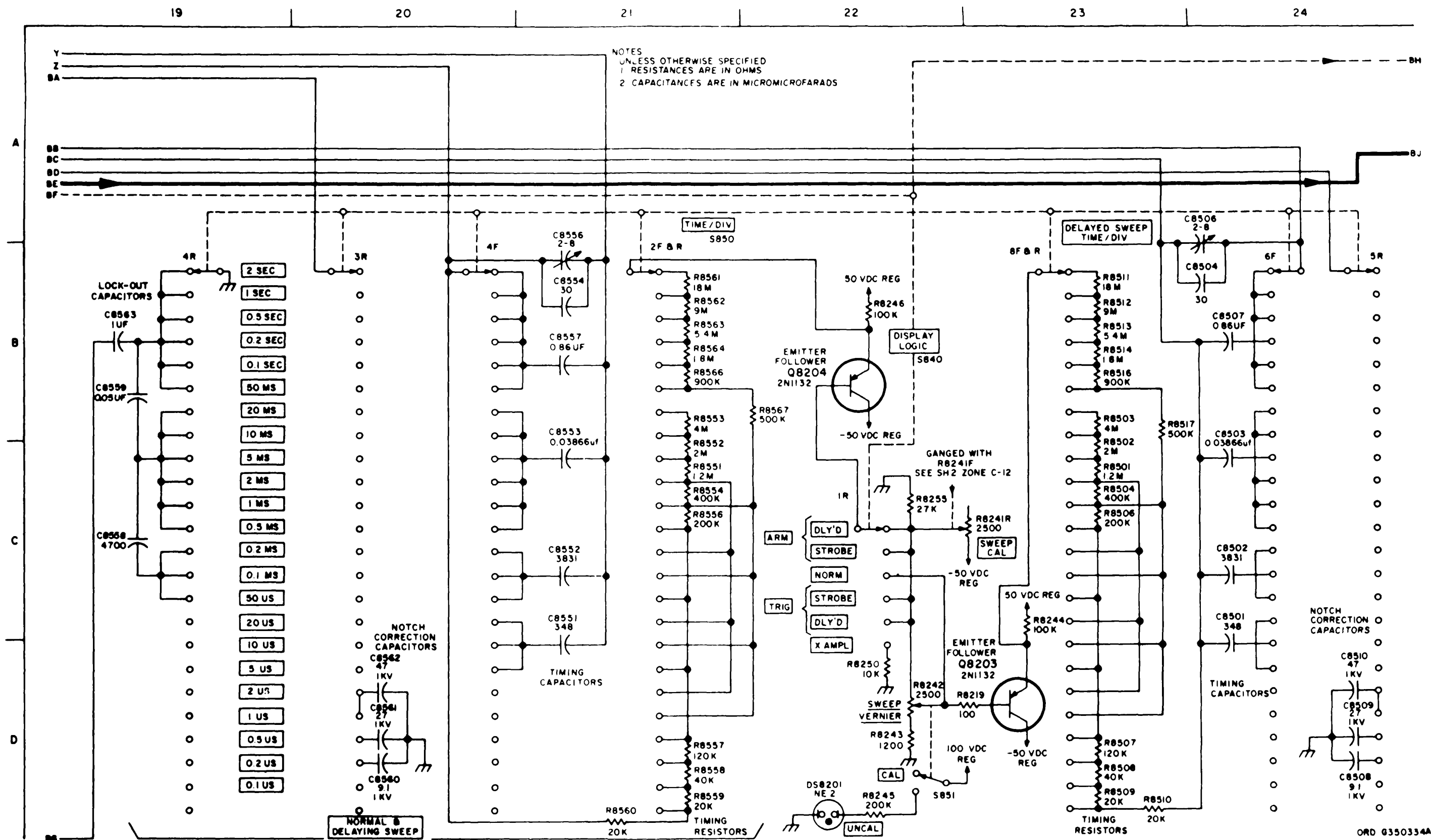

Figure 6-3. Delaying sweep plug-in, older version (type 74-13A with mod 101), schematic (sheet 4 of 6)

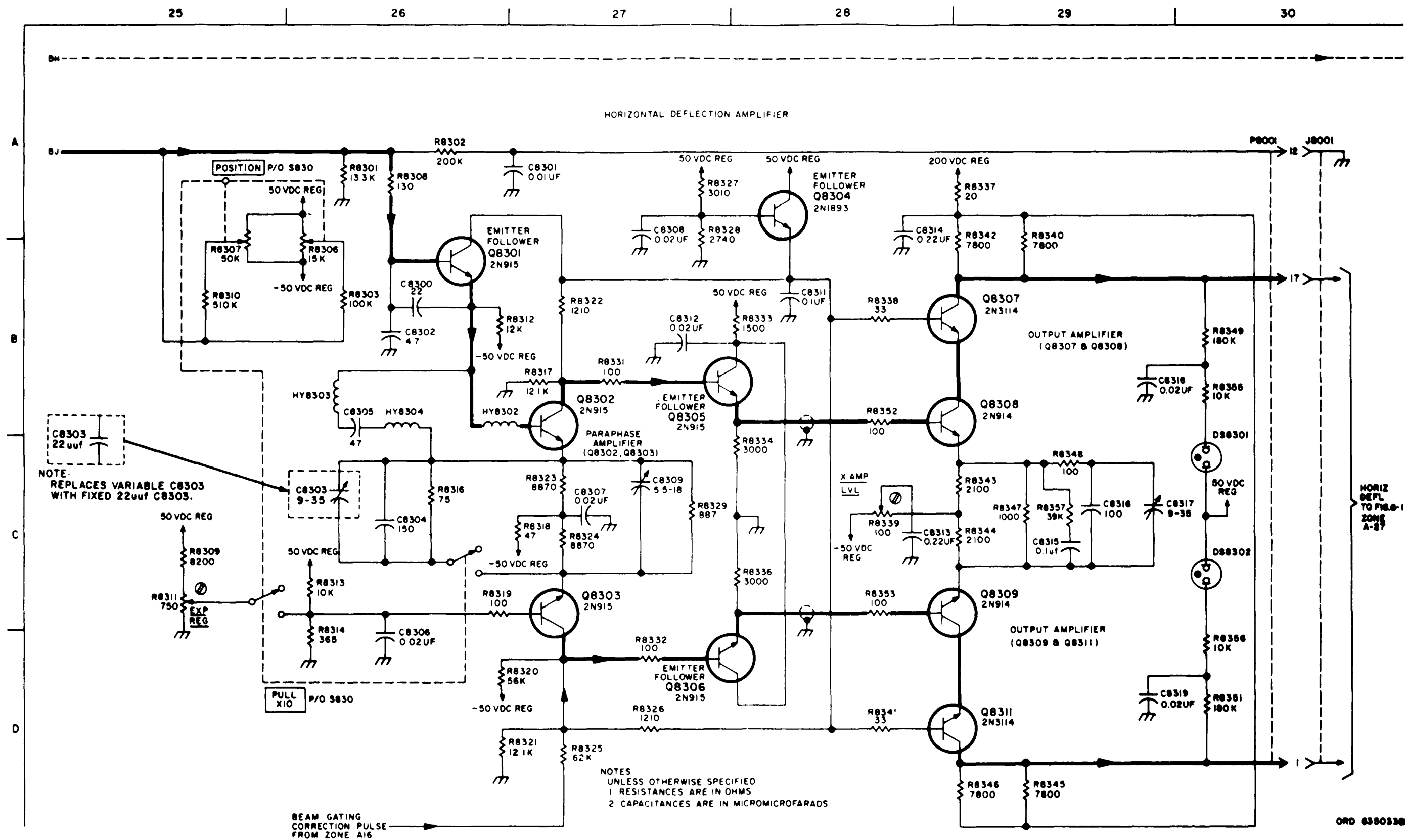

Figure 6-3. Delaying sweep plug-in, older version (type 74-13A with mod 101), schematic (sheet 5 of 6)

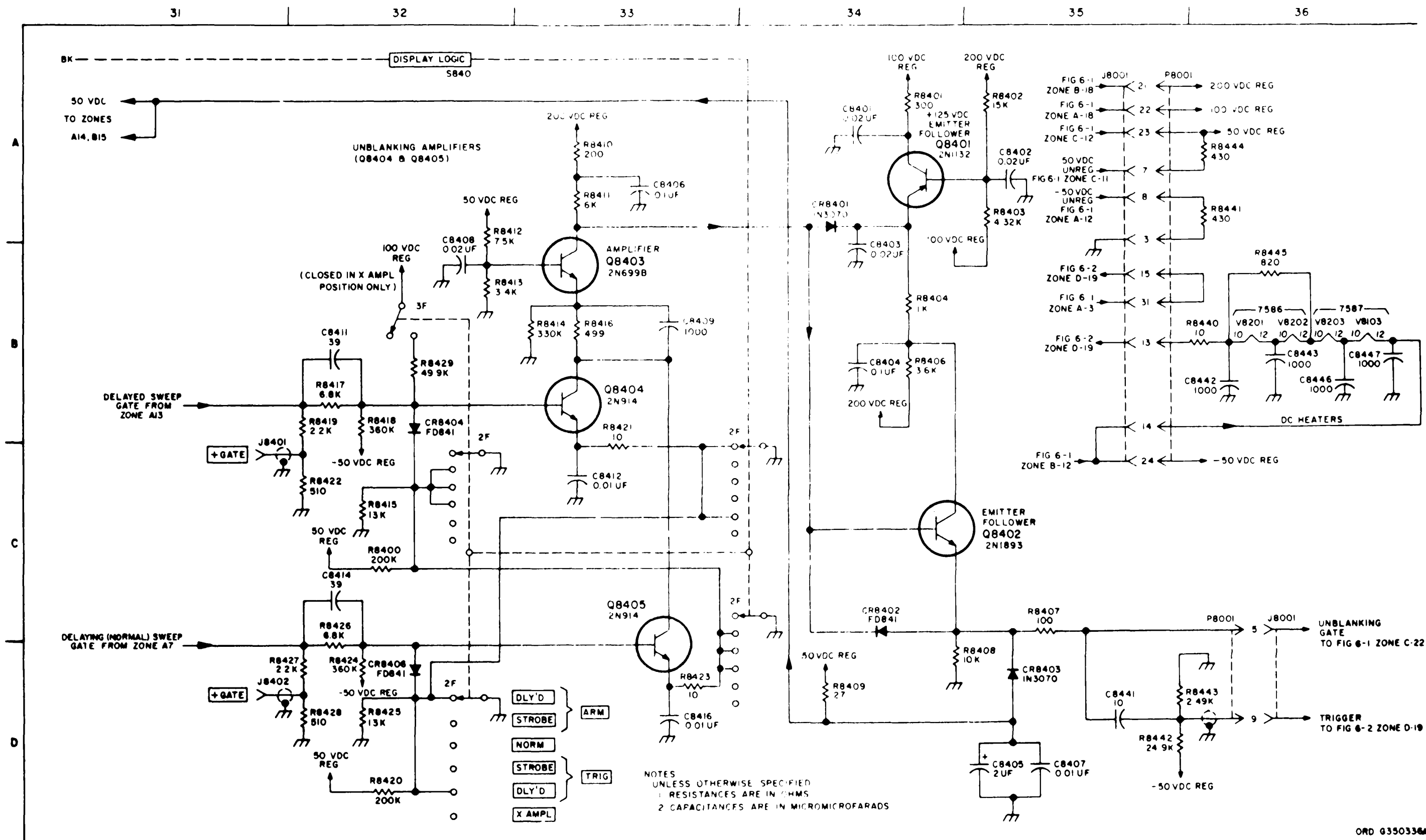
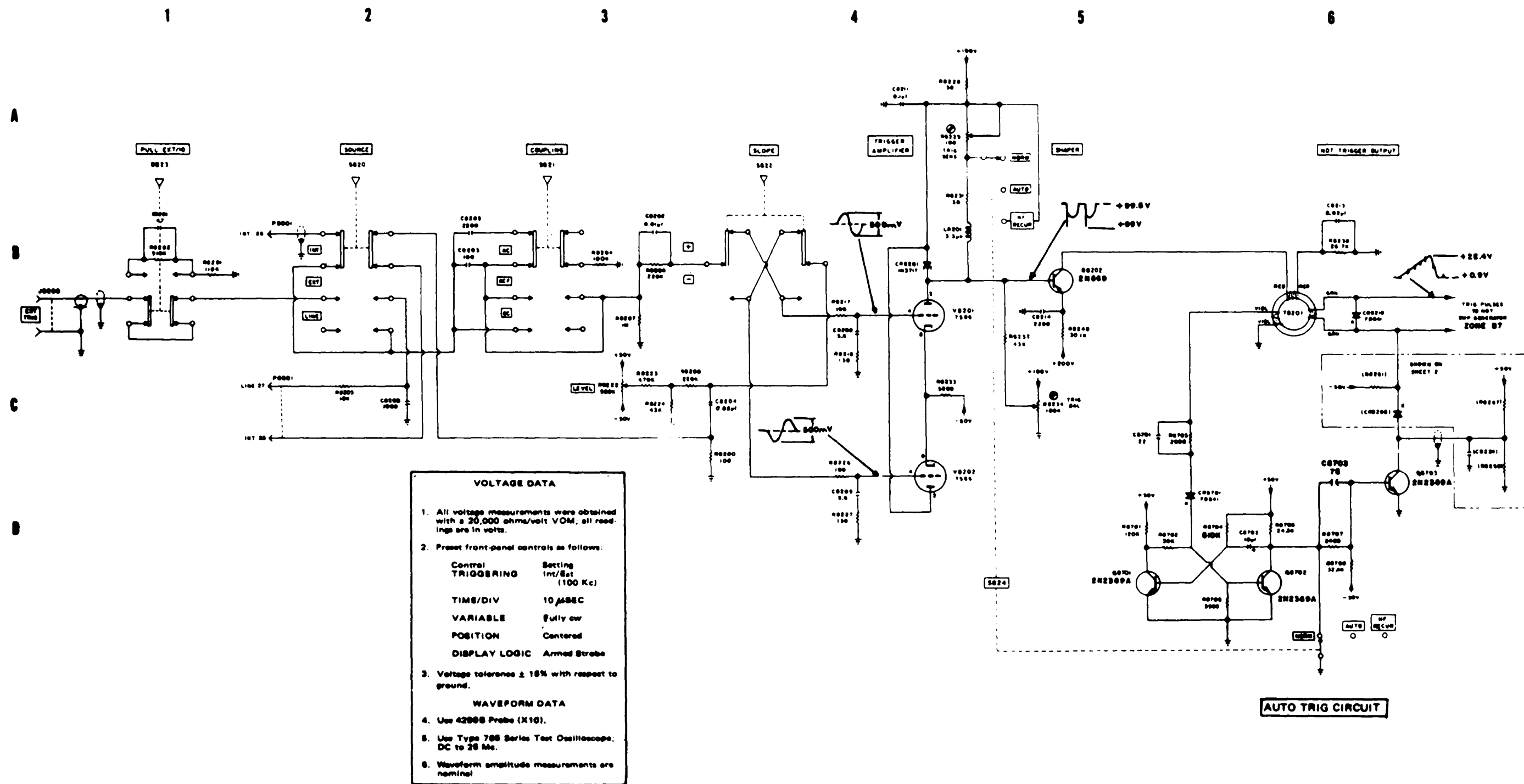

Figure 6-3. Delaying sweep plug-in, older version (type 74-13A with mod 101), schematic (sheet 6 of 6)

ORD 6350336A

NORMAL AND DELAYING TRIGGERING CIRCUIT



NOTE:
 1. RESISTOR VALUES ARE IN OHMS, K=THOUSAND, M=MILLION
 2. CAPACITOR VALUES ARE IN μF UNLESS OTHERWISE SPECIFIED
 3. Ⓢ SERVICE ADJUSTMENT
 4. Ⓢ FRONT PANEL OPERATOR ADJUSTMENT

MI 1286

Figure 6-4. Delaying sweep plug-in, newer version (type 74-13A with mod 101), schematic (sheet 1 of 7)

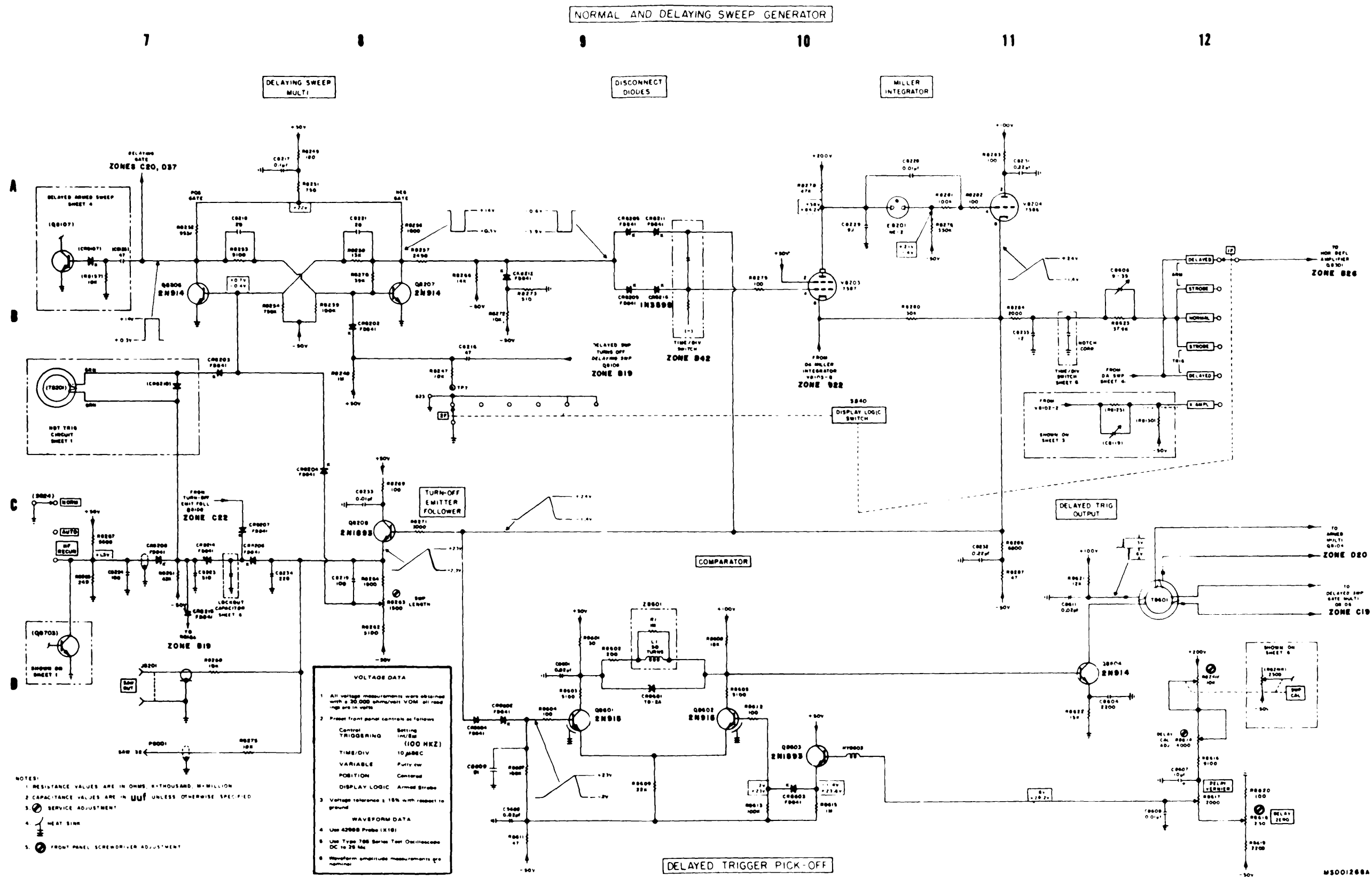

RELAYING GATE
ZONES C20, D37

DELAYED SWEEP MULT

DISCONNECT DIODES

MILLER INTEGRATOR

DELAYED TRIG PICK-OFF

COMPARATOR

TURN-OFF EMITTER FOLLOWER

DELAYED TRIG OUTPUT

- NOTES:
1. RESISTANCE VALUES ARE IN OHMS, K=THOUSAND, M=MILLION
 2. CAPACITANCE VALUES ARE IN μ f UNLESS OTHERWISE SPECIFIED
 3. SERVICE ADJUSTMENT
 4. HEAT SINK
 5. FRONT PANEL SCREWS/SLIPER ADJUSTMENT
- | VOLTAGE DATA | |
|---------------|---|
| 1 | All voltage measurements were obtained with a 20,000 ohms/volt VOM. All read ing is in volts. |
| 2 | Front panel control settings as follows:
Control TRIGGERING Setting Int/Ext (100 HKZ)
TIME/DIV 10 μ SEC
VARIABLE Fully on
POSITION Centered
DISPLAY LOGIC Armed Strobe |
| WAVEFORM DATA | |
| 3 | Voltage tolerance is 15% with respect to ground |
| 4 | Use 4200B Probe (X10) |
| 5 | Use Type 706 Series Test Oscilloscope DC to 25 Mc. |
| 6 | Waveform amplitude measurements are nominal |

Figure 6-4. Delaying sweep plug-in, newer version (type 74-13A with mod 101), schematic (sheet 2 of 7)

DELAYED TRIGGERING CIRCUIT

13 14 15 16 17 18

A

B

C

D

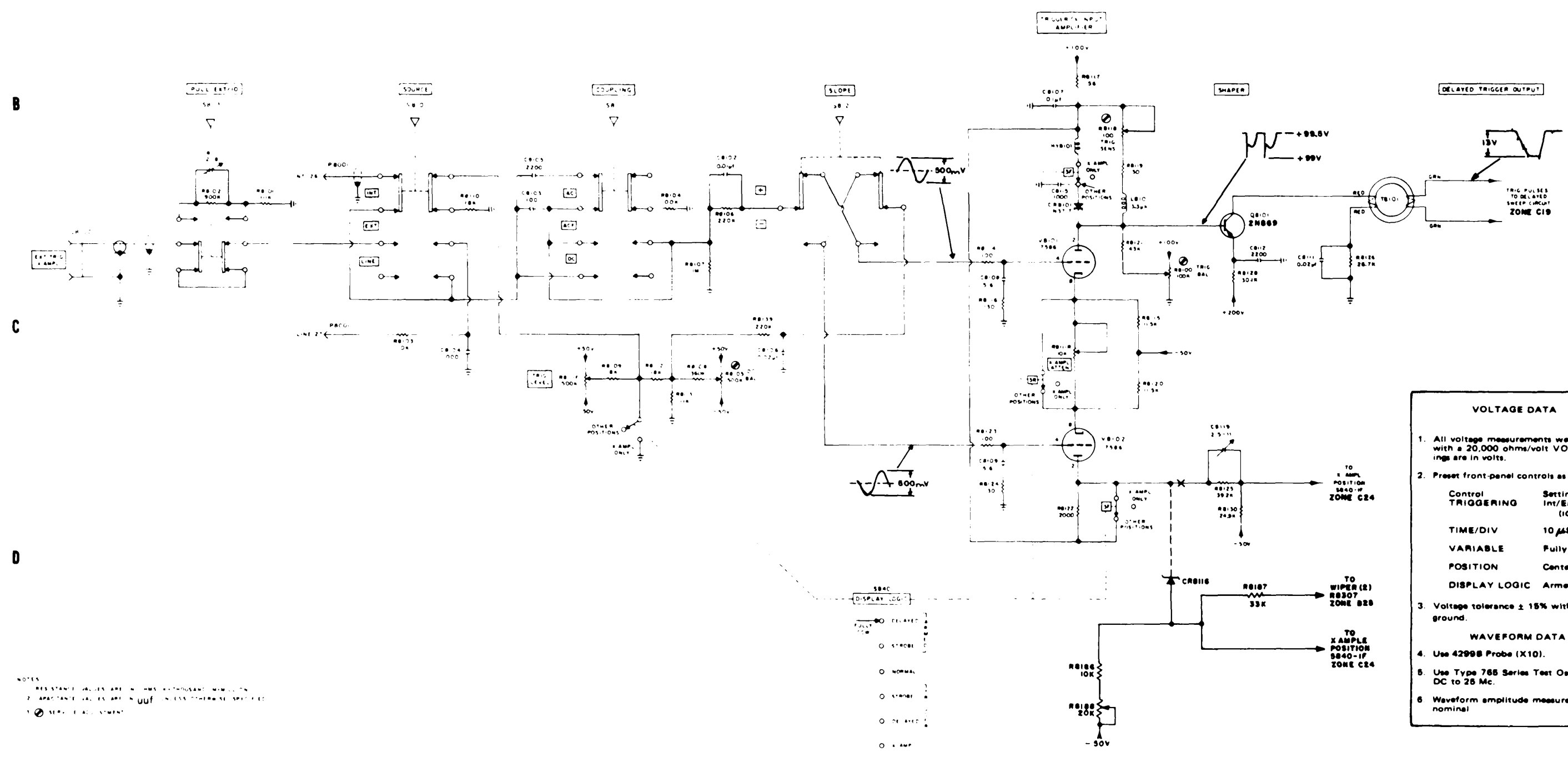

NOTES
1. RESISTANCE VALUES ARE IN OHMS UNLESS OTHERWISE SPECIFIED.
2. CAPACITANCE VALUES ARE IN μUF UNLESS OTHERWISE SPECIFIED.
3. ⊗ VERT. ADJUSTMENT

VOLTAGE DATA

- All voltage measurements were obtained with a 20,000 ohms/volt VOM, all readings are in volts.
- Preset front-panel controls as follows:

Control	Setting
TRIGGERING	Int/Ext (100 KHZ)
TIME/DIV	10 μSEC
VARIABLE POSITION	Fully cw
DISPLAY LOGIC	Armed Strobe
- Voltage tolerance ± 15% with respect to ground.

WAVEFORM DATA

- Use 4299B Probe (X10).
- Use Type 766 Series Test Oscilloscope, DC to 25 Mc.
- Waveform amplitude measurements are nominal.

MS001269A

Figure 6-4. Delaying sweep plug-in, newer version (type 74-13A and mod 101), schematic (sheet 3 of 7)

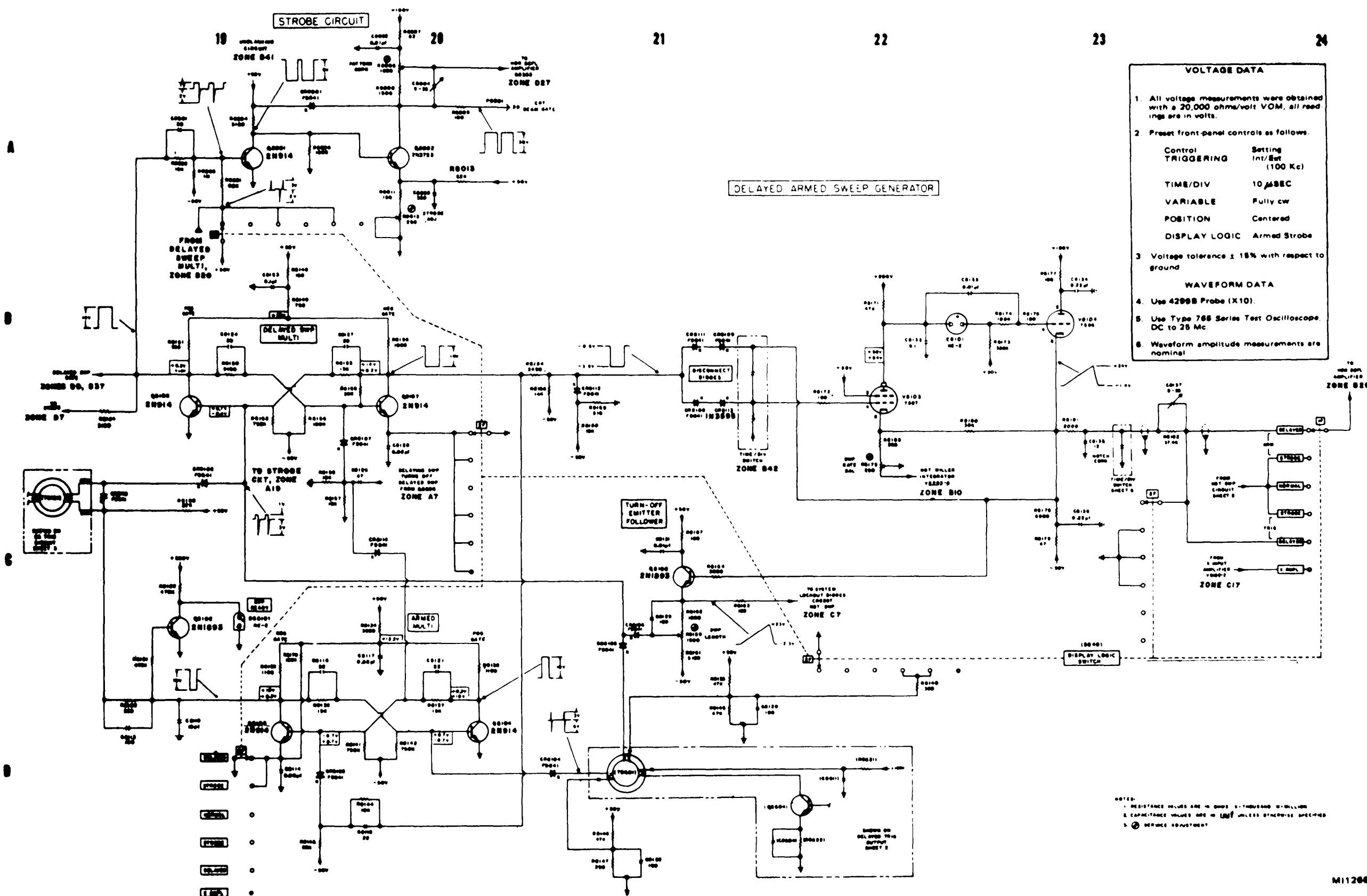

Figure 6-4. Delaying sweep plug-in, newer version (type 74-13A with mod 101), schematic (sheet 4 of 7)

HORIZONTAL DEFLECTION AMPLIFIER

25

26

27

28

29

30

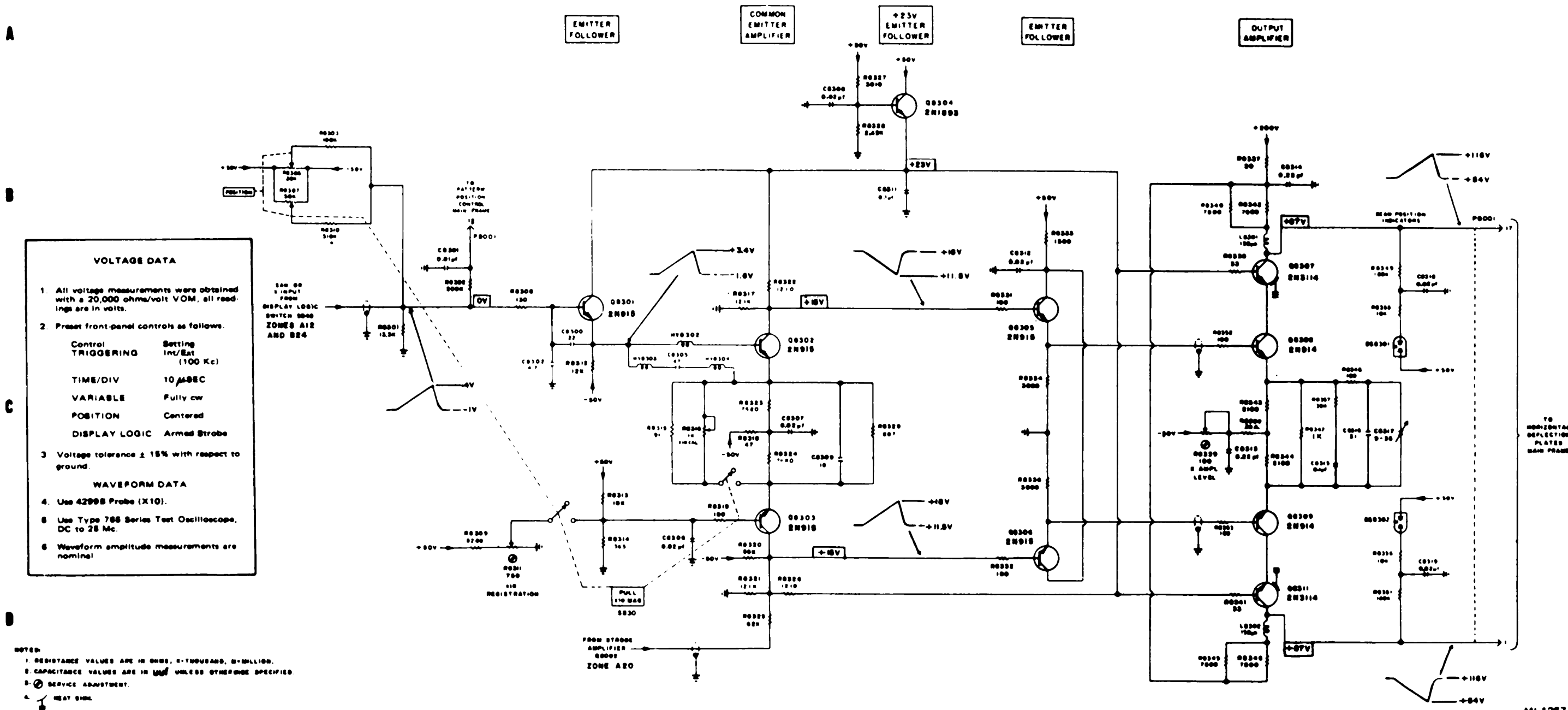

Figure 6-4. Delaying sweep plug-in, newer version (type 74-13A with mod 101), schematic (sheet 5 of 7)

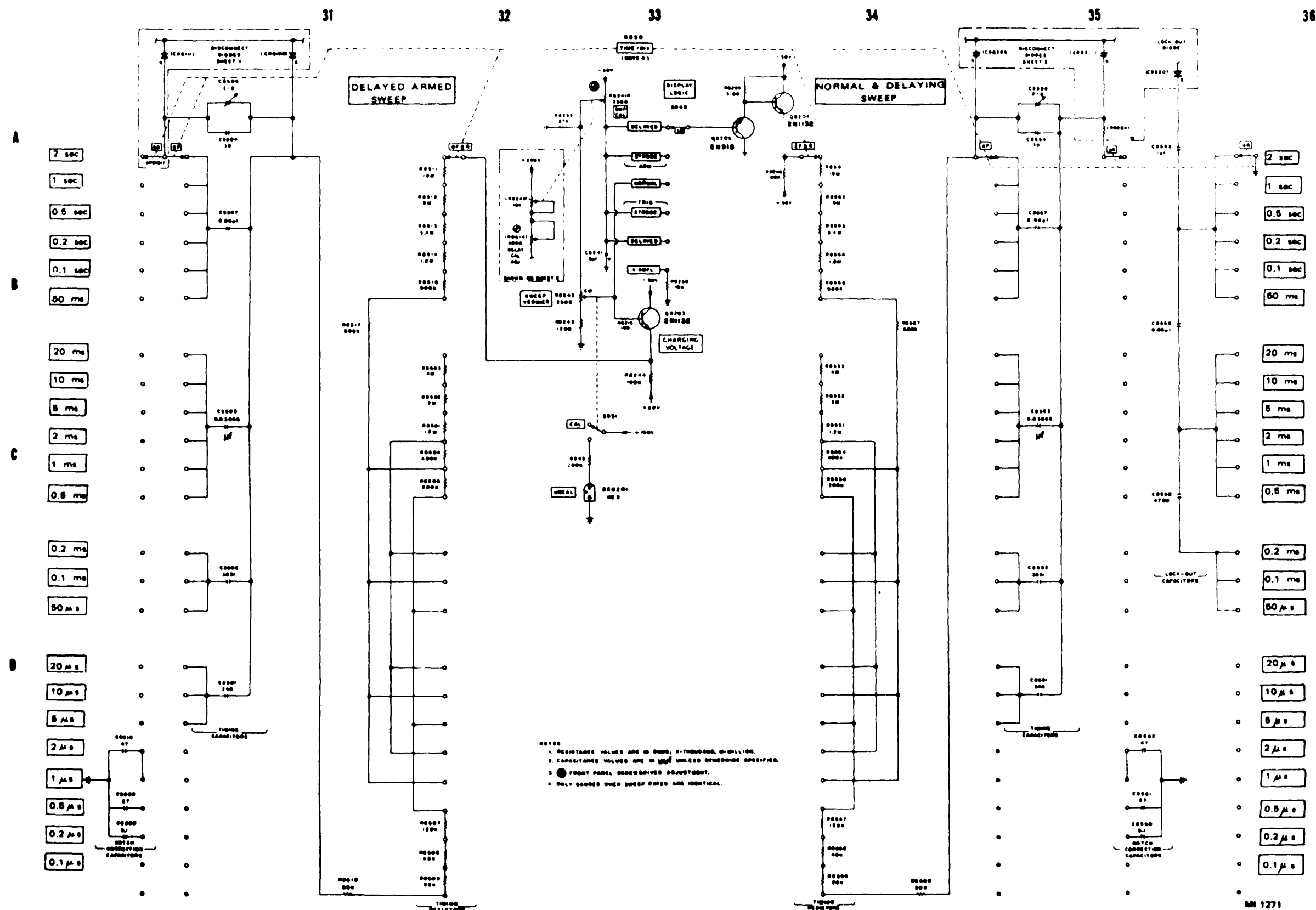

Figure 6-4. Delaying sweep plug-in, newer version (type 74-13A with mod 101), schematic (sheet 6 of 7)

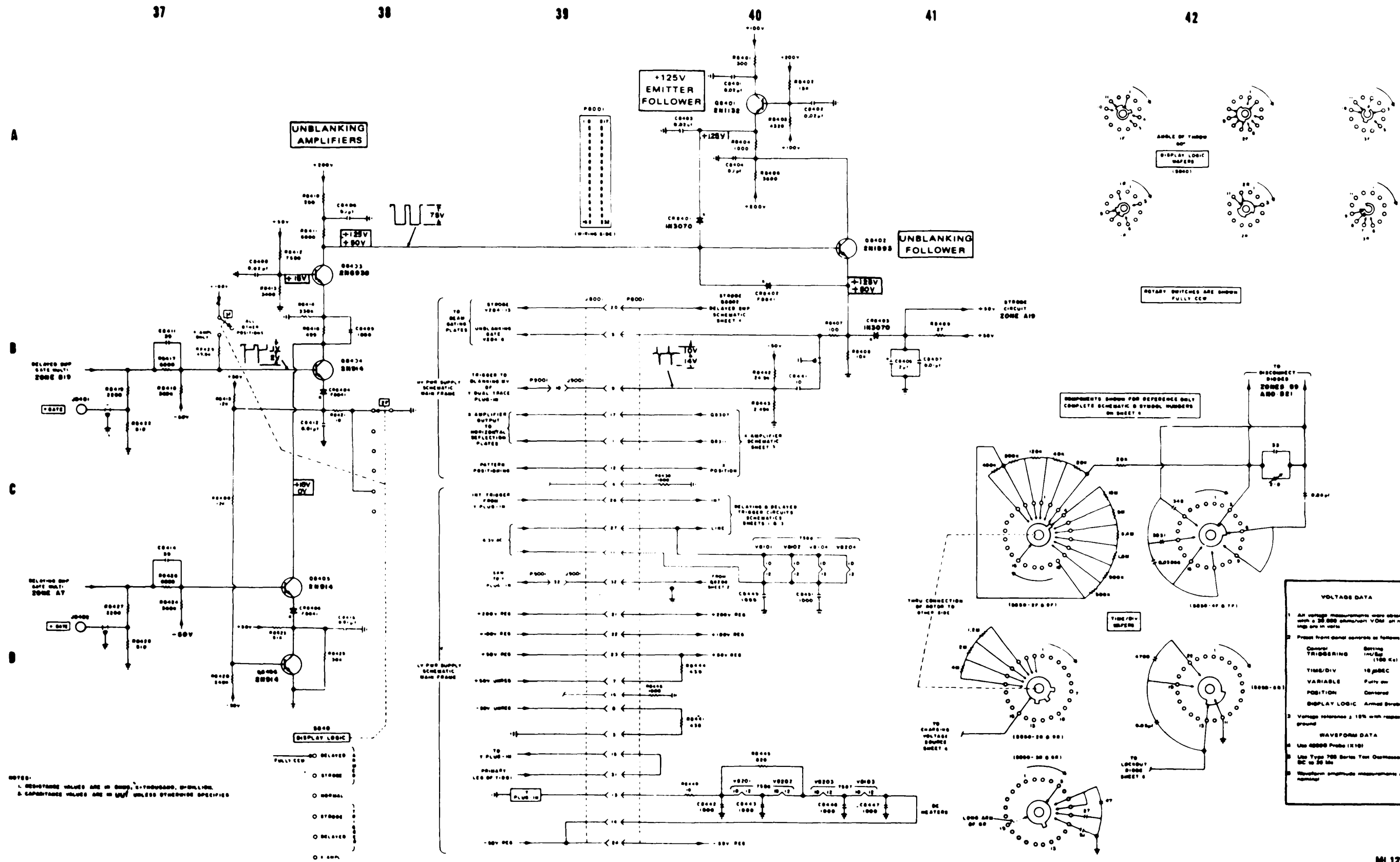

Figure 6-4. Delaying sweep plug-in, newer version (type 74-13A with mod 101), schematic (sheet 7 of 7)

CHAPTER 7

SHIPMENT AND STORAGE AND DESTRUCTION OF MATERIEL TO PREVENT ENEMY USE

Section I. SHIPMENT AND STORAGE

7-1. General

Commanders are responsible for insuring that all materiel issued or assigned to their command is maintained in a serviceable condition and properly cared for, and that personnel under their command comply with technical instructions. Lack of time, lack of trained personnel, or lack of proper tools may result in a unit being incapable of performing maintenance for which it is responsible. In such cases, unit commanders, with the approval of major commanders, may place materiel that is beyond the maintenance capability of the unit into administrative storage, or return it to the supply agency. When preparing the oscilloscope for administrative storage or shipment, the unit commander will be responsible for processing the materiel, including all basic issue items, in such a manner as to protect them against corrosion, deterioration, and physical damage during shipment or during periods of administrative storage. Personnel normally assigned to operate the oscilloscope may assist, as required, in preparing the oscilloscope for administrative storage or shipment.

7-2. Transportation Data

The physical characteristics of the oscilloscope are as follows:

Length.....	23 in.
Width.....	17 3/4 in.
Height.....	8 1/4 in.
Weight.....	41 lbs.

7-3. Packaging the Oscilloscope (Fig. 7-1)

a. *General.* The exact procedure for packaging depends on the material available and the conditions under which the equipment is to be shipped. Use the original packaging materials if they are available, but don't use the old desiccant or humidity indicator. Adapt the procedures outlined below whenever circumstances permit.

b. *Materials.* The following materials are required for packaging the oscilloscope:

- (1) Paper, wrapping, MIL-C-17667
- (2) Cushioning material PPP-C-843
- (3) Box, fiberboard, PPP-B-636
- (4) Desiccant MIL-D-3464
- (5) Tape, masking, PPP-T-76
- (6) Indicator, humidity, MS-20003-2
- (7) Barrier material MIL-B-131
- (8) Cushioning material MIL-C-7769
- (9) Wooden box

For stock numbers of materials, consult SB 38-100.

Note. Prior to packaging the oscilloscope, verify that the delaying sweep plug-in assembly and dual trace plug-in assembly are secured to the main frame by their respective locking screws.

c. *Packaging.*

- (1) Wrap the oscilloscope in paper MIL-C-17667 (1), and secure it with tape PPP-T-76.
- (2) Overwrap the oscilloscope with cushioning material PPP-C-813 (2) and secure it with strips of tape.
- (3) Place the wrapped oscilloscope in a fiberboard box PPP-B-636 (3). Fill any voids in the box with wads of cushioning material PPP-C-843 (4).
- (4) Distribute bags of desiccant MIL-D-34164 (5) (54 units) throughout the box.
- (5) Place the technical manuals in a fabricated envelope, sealed with tape, on top of the box (6).
- (6) Close the box, and seal the top and bottom flap seams with tape. At one end, secure humidity indicator (card) MS-20003-2 (7) to the box with strips of tape. Blunt the corners of the box.

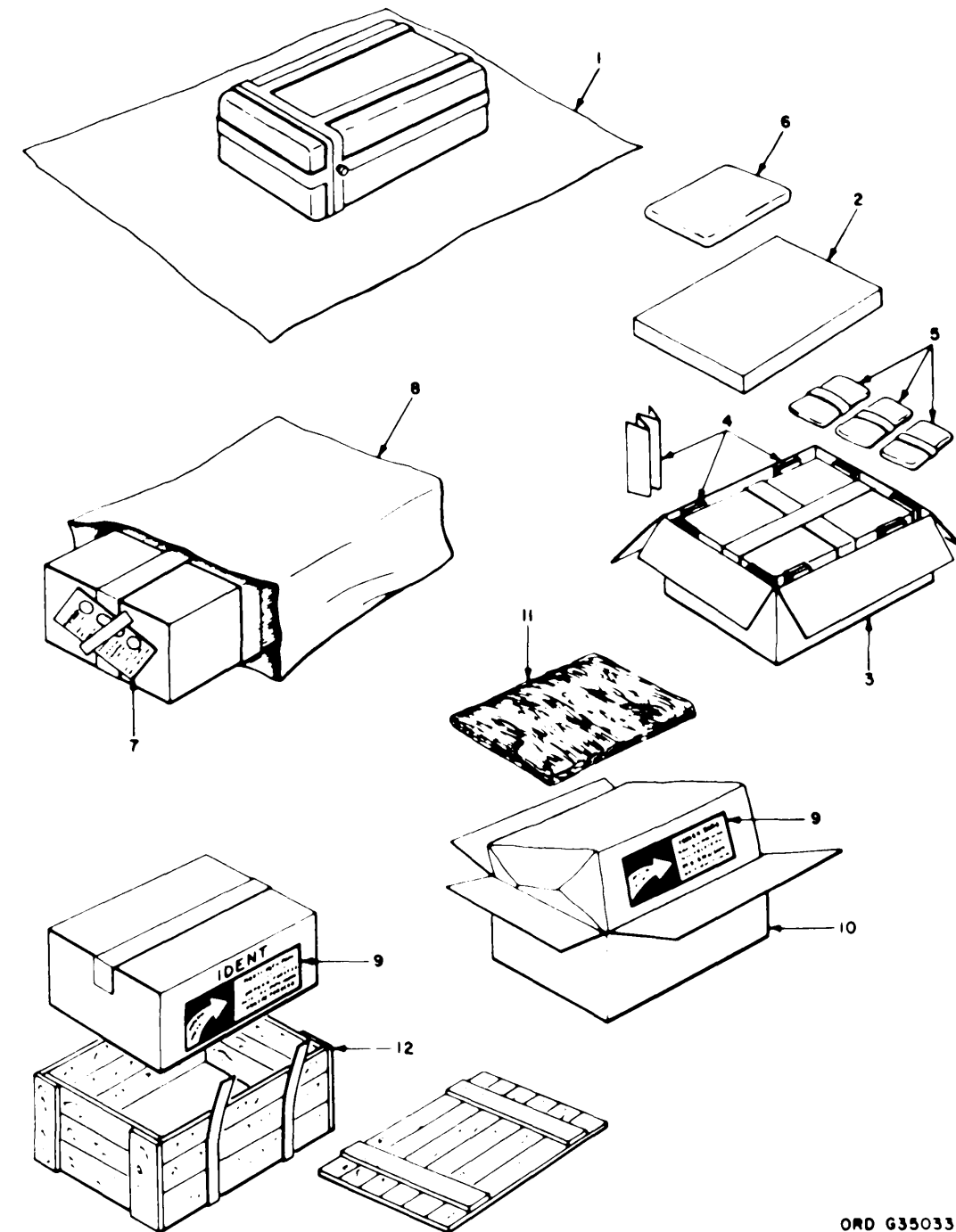

ORD G350337

Figure 7-1. Oscilloscope packaging.

- (7) Place the boxed oscilloscope in barrier material MIL-B-131, Class 1 (8). Exhaust the air from the package and heat-seal it. Identify the contents by stenciling the name and Federal stock number on the box. Apply a method II label (TM 38-230) (9).
- (8) Place the bagged oscilloscope in a fiber-board box PPP-B-636 (10). Place sufficient cushioning material MIL-C-7769 (11) at the top, bottom, sides, and ends of the box to insure a snug fit.
- (9) Close the box, and seal both top and bottom flap seams with tape. Apply identification and Method II labels (9).

(10) Fabricate a wooden box to size, insert the boxed oscilloscope, and seal with nails and metal straps (12).

d. *Marking.* Apply a Method II label (TM 38-230). If available, use standard paste on precautionary stickers such as Fragile, Handle with care, etc. Otherwise use a marking pencil or stencil and indicate that the contents of the container are fragile. Indicate the contents of the shipping container by stenciling the oscilloscope name and Federal stock number on the upright part of the box.

e. *Army Shipping Documents.* Prepare all Army shipping documents in accordance with AR 725-50.

7-4. Storage

a. *Time Limitations.* Administrative storage is restricted to a period of 90 days and must not be extended beyond this time limit unless the materiel is reprocessed in accordance with *b* below.

b. *Storage Procedure.*

- (1) Disassembly will be limited to that necessary to clean and preserve surfaces. Except as otherwise noted and to the maximum extent consistent with safe storage, materiel will be placed in administrative storage in as nearly a completely assembled condition as practicable. Equipment will be installed and adjustments made so that the materiel may be placed in service and operated with a minimum of delay.
- (2) Materiel must be stored on level ground in the most favorable location available, preferably one that affords protection from exposure to the elements and from pilferage.
- (3) Perform a quarterly preventive-maintenance (PM) service on materiel intended for administrative storage. Make reference to the paragraphs or manual where preventive-maintenance instructions are provided.
- (4) Protect materiel with covers provided.
- (5) Provide access to the materiel to permit inspection, servicing, and subsequent removal from storage.
- (6) Mark or tag the materiel "Administrative Storage." (Materiel so marked will not be operated while in this category.)

c. *Inspection in Administrative Storage.*

- (1) Visual inspection of materiel in administrative storage must be conducted at least once each month and immediately following hard rains, heavy snowstorms, windstorms, or other severe weather conditions. Disassembly will be performed as necessary to ascertain fully the extent of any deterioration or damage found. A record of these inspections will be maintained for materiel in administrative storage and attached to the materiel in such a manner as to protect the record from the elements.
- (2) When rust or deterioration is found on any unpainted area, necessary reprocessing for administrative storage will be accomplished immediately. Damages caused to the materiel by severe weather conditions will be promptly repaired. Deterioration or damage to basic issue items packaging will be repaired as necessary. Painted surfaces showing evidence of deterioration will be thoroughly cleaned, dried, and repainted, using paint of the same quality and color as the original paint.

Section II. DESTRUCTION OF MATERIEL TO PREVENT ENEMY USE

7-5. General

a. The destruction procedures given below will be used to prevent the enemy from using or salvaging this equipment. Destruction of the equipment will be undertaken by the user when, in the judgment of the unit commander, such action is necessary in accordance with orders of, or policy established by, the Army commander.

b. Any or all of the following methods of destruction may be used. The time available will usually be the most important factor to consider in deciding which methods will be used, but the tactical situation must also be considered. If a number (if the oscilloscopes are in the same or near-by installations, it is better to demolish completely the same portions of all the oscilloscopes than to damage them all partially. The most applicable means of destruction are:

- (1) *Mechanical.* Destruction by mechanical means requires an ax, pick, mallet, sledge, crowbar, or similar implement.
- (2) *Burning.* Destruction by burning requires gasoline, oil, incendiary grenades, or other flammables.
- (3) *Demolition.* Destruction by demolition requires suitable explosives or ammunition.
- (4) *Gunfire.* Destruction by gunfire requires any type caliber rifle or handgun that is capable of inflicting damage to the oscilloscope.

7-6. Destruction by Smashing and Burning

a. *Smash.*

- (1) Remove the main frame from its protective cover and remove the dual trace and delaying sweep plug-in units. Use the heaviest tool on hand to smash the plug-in units front panel controls and connectors. Use downward blows to bend all shafts and then smash the units completely.

Warning: Carelessness may result in severe injury from flying glass.

- (2) Smash the cathode-ray tube, using a long-handled heavy tool. Cover the front of the oscilloscope with several thicknesses of tarpaulin or other heavy cloth; keep all other personnel at a safe distance, and stand behind the oscilloscope. Swing down on the face of the oscilloscope to smash the tube.
- (3) Use any heavy tool to smash the main frame front panel completely.
- (4) Disable the fan with a heavy blow and then smash the interior components of the main frame.
- (5) Smash the probe body, probe tips, and cut the power cord, probe cables, and jumpers in a number of places.

b. *Burn.* Burn as much of the equipment as is flammable. Burn instruction books first. Pour gasoline over the cut cables and the two plug-in units and ignite them. To destroy the interior of the oscilloscope, stuff rags or waste into the plug-in cavities. Then pour on gasoline and ignite. Flame throwers or incendiary grenades, if available, are better for this purpose.

7-7. Destruction by Explosives

Warning: Be extremely careful with explosives and incendiary devices. Use them only if the need is urgent. Use this method only if thoroughly familiar with FM 5-25. Training and careful planning are essential.

a. *Explode.* Use explosives only if time does not permit complete destruction by other means. Powder charges, fragmentation grenades, or incendiary grenades may be used. Incendiary grenades are effective and somewhat safer to use. Remove the oscilloscope from its cover and place an incendiary or fragmentation grenade, or a small powder charge inside the main frame. Get away from the unit after the charge is placed.

b. *Dispose.* Bury or scatter all destroyed parts or throw them into near-by waterways. This is especially important if the oscilloscope has not been completely destroyed.

7-8. Destruction by Gunfire

This method of destruction cannot be relied upon to render the oscilloscope completely useless. Use this method only if conditions disallow destruction of the oscilloscope by smashing, burning or demolition. Use small arms to fire upon the oscilloscope for full effect.

Warning: Firing on the oscilloscope should be performed from a safe location.

APPENDIX
REFERENCES

1-1. Publications References

The following is a list of all publications referenced in this manual:

■ The Army Maintenance Management System (TAMM's).....	TM 38-750
Explosives and Demolitions	FM 5-25
First Aid for Soldiers	FM 21-11
Handling and Disposal of Unwanted Radioactive Material.....	TM 3-261
Organizational, DS, GS, and Depot Maintenance Repair Parts and Special Tool Lists for Oscilloscope FD-765MH.....	TM 9-6625-1753-25P
Preservation, Packaging, and Packing of Military Supplies and Equipment	TM 38-230
Preservation, Packaging, and Packing Materials, Supplies, and Equipment Used by the Army	SB 38-100
Requisitioning, Receipt, and Issue System	AR 725-50

1-2. Other Publications

Refer to TM 9-1400-500-10 for a list of other publications pertinent to this materiel and associated equipment.

INDEX

	Paragraph, Figure, Table Number	Paragraph, Figure, Table Number
Amplifiers:		
Horizontal deflection, circuit, newer version 74-13A	3-23	
Horizontal deflection amplifier, older version 74-13A	3-15	
Preamp, 76-02A	3-7	
Vertical deflection amplifiers, 76-02A	3-11	
Preamp, 79-02A	3-11.1	
Attenuation:		
General	3-2a, 3-2. 1b	
Input voltage attenuation, 76-02A	3-6b	
Interstage voltage attenuation, 76-02A	3-7c	
Automatic triggering, older version 74-13A	3-12e	
Automatic triggering, newer version 74-13A	3-17b	
Beam gate circuit, older version 74-13A	3-13f	
Block diagrams:		
Dual trace plug-in 79-02A	F4-4.1	
Power supply	F4-1	
Oscilloscope	F4-2	
Capabilities	1-9	
Dual trace	1-9a	
Delayed sweep	1-9b	
Channel switching, 76-02A:	3-8	
Channel A	3-8a	
Channel B	3-8b	
Alternate switching	3-8c	
Chopped	3-8d	
Channel A + Channel B	3-8e	
Check procedures:		
Oscilloscope check	2-15	
Controls and indicators:		
Main frame	2-4	
Dual trace plug-in	2-5	
Dual trace plug-in 79-02A	2-5.1	
Delaying sweep plug-in	2-6	
Corrective maintenance:		
Removal of the main frame and plug-in assemblies	5-11	
Replacement of the CRT	5-12	
Replacement of the fan assembly	5-13	
CRT circuit, older version 74-13A	3-16	
Beam intensity	3-16a	
Focusing	3-16b	
Astigmatism	3-16c	
Pattern correction	3-16d	
Beam rotate	3-16e	
Delay line drivers, 75-02A	3-9	
Delayed sweep, functional theory, older version 74-13A	3-14	
Triggered-strobe	3-14a	
Triggered-delayed	3-14b	
Armed-strobe	3-14c	
Armed-delayed	3-14d	
Delayed sweep, functional theory, newer version 74-13A:		
Triggered-strobe	3-19	
Triggered-delayed	3-20	
Armed-strobe	3-21	
Armed-delayed	3-22	
Delayed sweep, general theory	3-3c	
Triggered-strobe	3-3c(1)	
Triggered-delayed	3-3c(2)	
Armed-strobe	3-3c(3)	
Armed-delayed	3-3c(4)	
Delayed trigger generation, older version 74-13A	3-12	
Delayed trigger generation, newer version 74-13A	3-17	
Delaying sweep plug-in:		
General theory	3-3	
Functional theory, older version 74-13A	3-12	
Functional theory, newer version 74-13A	3-17	
Destruction of materiel to prevent enemy use:		
Destruction by smashing and burning	7-6	
Destruction by explosives	7-7	
Destruction by gunfire	7-8	
Differences among models	1-5	
Dual trace plug-in:		
General theory	3-2	
Functional theory	3-6	
Forms, records, and reports	1-4	
Functional schematics:		
Power supply	F4-3	
Dual trace plug-in 76-02A	F4-4	
Dual trace plug-in 79-02A	F4-4.1	
Delaying sweep plug-in, older version	F4-5	
Functional theory, delaying sweep plug-in, older version 74-13A:		
Triggering	3-12	
Normal sweep	3-13	
Delayed sweep	3-14	
Horizontal deflection amplifier	3-15	
CRT	3-16	

	Paragraph, Figure, Table Number		Paragraph, Figure, Table Number
Functional theory, dual trace plug-in 76-02A:			
Signal coupling and voltage attenuation	3-6	Lockout circuit, older version 74-13A	3-13 <i>d</i>
Preamplifier.....	3-7	Maintenance allocation.....	1-3
Channel switching.....	3-8	Methods of coupling trigger input, older version 74-13A	3-12 <i>b</i>
Delay line drivers	3-9	AC	3-12 <i>b</i> (1)
Trigger pick-off circuit	3-10	ACF	3-12 <i>b</i> (2)
Vertical deflection amplifier.....	3-11	Nomenclature and reference designations	1-6
Functional theory, dual trace plug-in 79-02A and CRT termination network:		Normal weep, general theory.....	3-3 <i>b</i>
Preamplifier.....	3-11.1	Sweep gate.....	3-3 <i>b</i> (1)
Mode selection	3-11.2	Linear sweep.....	3-3 <i>b</i> (2)
Common amplifier section and CRT termination network.....	3-11.3	Lockout output.....	3-3 <i>b</i> (3)
Functional theory, power supply:		Beam gate circuit.....	3-3 <i>b</i> (4)
Low-voltage power supply, oscilloscope 765MH.....	3-4	Normal sweep, functional theory, older version 74-13A	3-13
Low-voltage power supply, oscilloscope 765MH/F and newer 765 MH model.....	3-5.1	Normal sweep gate.....	3-13 <i>a</i>
High-voltage supply, oscilloscope 765MH	3-5	Sawtooth generator.....	3-13 <i>b</i>
High-voltage supply, oscilloscope 765MH/F and newer 765MH models	3-5.2 <i>b</i>	Sweep duration	3-13 <i>c</i>
General theory, power supply.....	3-1	Lockout circuit	3-13 <i>d</i>
General theory, delaying sweep plug-in	3-3	HF stability (recurrent sweep)	3-13 <i>e</i>
Delayed sweep.....	3-3 <i>c</i>	Beam gate circuit.....	3-13 <i>f</i>
External sweep.....	3-3 <i>d</i>	Normal sweep circuit, functional theory, newer version 74-13A	3-18
Horizontal deflection amplifier.....	3-3 <i>e</i>	Normal trigger generation, older version 74-13A.....	3-12 <i>d</i>
Normal sweep	3-3 <i>b</i>	Input.....	3-12 <i>d</i> (1)
Triggering.....	3-3 <i>a</i>	Tunnel diode	3-12 <i>d</i> (2)
General theory, dual trace plug-in 76-02A	3-2	Shaping.....	3-12 <i>d</i> (3)
Attenuation	3-2 <i>a</i>	Operation under usual conditions:	
Amplification	3-2 <i>b</i>	Starting procedure	2-7
Mode selection	3-2 <i>c</i>	Use of probe	2-8
Delay line	3-2 <i>d</i>	Operation of the dual trace plug-in or dual trace plug-in 79-02A	2-9
Vertical deflection amplifier.....	3-2 <i>e</i>	Operation of the delaying sweep plug-in.....	2-10
General triggering information	2-10 <i>a</i>	Voltage measurements	2-11
Triggering sources for normal and delayed sweeps	2-10 <i>a</i> (1)	Time measurements.....	2-12
Trigger coupling for normal or delayed sweep.....	2-10 <i>a</i> (2)	Phase shift measurements	2-13
Use of SLOPE switch and LEVEL control.....	2-10 <i>a</i> (3)	Operating modes, delaying sweep plug-in:	
Use of the HF STAB control	2-10 <i>a</i> (4)	Normal sweep:	
HF stability (recurrent sweep), older version 74-13A	3-13	general theory	3-3 <i>b</i>
High-voltage rectifier, oscilloscope 765MH.....	3-5 <i>b</i>	functional theory, older version 74-13A	3-13
Voltage tripler.....	3-5 <i>b</i> (1)	functional theory, newer version 74-13A.....	3-18
Negative 130 volt supply	3-5 <i>b</i> (2)	Triggered-strobe:	
High-voltage supply, oscilloscope 765MH	3-5	general theory	3-3 <i>c</i> (1)
Oscillator	3-5 <i>a</i>	functional theory, older version 74-13A	3-14 <i>a</i>
High-voltage rectifier	3-5 <i>b</i>	functional theory, newer version 74-13A.....	3-19
High-voltage regulation.....	3-5 <i>c</i>	Triggered-delayed:	
Horizontal deflection amplifier, older version 74-13A	3-15	general theory	3-3 <i>c</i> (2)
Normal sweep amplification.....	3-15 <i>a</i>	functional theory, older version 74-13A	3-14
X amplifier only.....	3-15 <i>b</i>	functional theory, newer version 74-13A.....	3-20
Horizontal deflection circuit.....	3-23	Armed-strobe:	
		general theory	3-3 <i>c</i> (3)
		functional theory, older version 74-13A	3-14 <i>c</i>
		functional theory, newer version 74-13A.....	3-21
		Armed-delayed:	
		general theory	3-3 <i>c</i> (4)
		functional theory, older version 74-13A	3-14 <i>d</i>
		functional theory, newer version 74-13A.....	3-22

	Paragraph, Figure, Table Number	Paragraph, Figure, Table Number
External sweep:		
X amplifier only:		
general theory	3-3 <i>d</i>	
functional theory	3-15 <i>b</i>	
Operating modes, dual trace plug-in 76-02A		
Channel A:		
general theory	3-2 <i>c</i> (1)	
functional theory	3-8 <i>a</i>	
Channel B:		
general theory	3-2 <i>c</i> (2)	
functional theory	3-8 <i>b</i>	
Alternate:		
general theory	3-2 <i>c</i> (3)	
functional theory	3-8 <i>c</i>	
Chop:		
general theory	3-2 <i>c</i> (4)	
functional theory	3-8 <i>d</i>	
A + B:		
general theory	3-2 <i>c</i> (5)	
functional theory	3-8 <i>e</i>	
Operating modes, 79-02A	3-11.2	
Operation and maintenance data	1-8	
Operation of the delaying sweep plug-in	2-10	
General triggering information	2-10 <i>a</i>	
Triggering instructions for normal sweep	2-10 <i>b</i>	
Use of the PULL x 10 switch	2-10 <i>c</i>	
Triggering instruction for delaying sweep	2-10 <i>d</i>	
Operation of the dual trace plug-in	2-9	
Single trace presentation	2-9 <i>a</i>	
Dual trace presentation	2-9 <i>b</i>	
Physical description:	1-7	
Main frame	1-7 <i>b</i>	
Dual trace plug-in and delaying sweep-in	1-7 <i>c</i>	
Accessory kit	1-7 <i>d</i>	
Polarity selection of input signal, older version 74-13A	3-12 <i>c</i>	
+ position	3-12 <i>c</i> (1)	
- position	3-12 <i>c</i> (2)	
Power supply:		
General theory	3-1	
Functional theory	3-5 - 3-5.1	
Low voltage power supply, oscilloscope 765MH	3-4	
Primary power	3-4 <i>a</i>	
Temperature control	3-4 <i>b</i>	
Low voltage rectification	3-4 <i>c</i>	
Voltage regulators	3-4 <i>d</i>	
Calibration voltage(1v-p-p)	3-4 <i>e</i>	
Low voltage power supply, oscilloscope 765MH/F and newer 765MH models	3-5.1	
Preamplifier, 76-02A	3-7	
Paraphase amplifier	3-7 <i>a</i>	
reamplification	3-7 <i>b</i>	
Interstage voltage attenuation	3-7 <i>c</i>	
Preamplifier, 79-02A	3-11.1	
Packaging the oscilloscope:		
Materials	7-3 <i>b</i>	
Packaging	7-3 <i>c</i>	
Marking	7-3 <i>d</i>	
Army shipping documents	7-3 <i>e</i>	
Preventive maintenance:		
Preventive maintenance checks and services	5-5	
Lubrication instructions	5-6	
Precautions	5-7	
Cleaning instructions	5-8	
Probe (See Operation under usual conditions)		
Regulators, voltage, oscilloscope 765MH	3-4 <i>d</i>	
-50 volts	3-4 <i>d</i> (1)	
50 volts	3-4 <i>d</i> (2)	
100 volts	3-4 <i>d</i> (3)	
200 volts	3-4 <i>d</i> (4)	
High-voltage regulation	3-5 <i>c</i>	
Regulators, voltage, oscilloscope 765MH/F and newer 765MH models	3-5.1 <i>b</i>	
Removal of the main frame and plug-in assemblies	5-11	
Repair parts, tools, and equipment		
Repair parts	5-2	
Common tools and equipment	5-3	
Reporting equipment publication improvements	1-2	
Sawtooth generator (Miller integrator)	3-13 <i>b</i> , 3-18 <i>b</i>	
Schematics:		
Delaying sweep plug-in, older version (type 74-13A with mod 101)	F6-3	
Delaying sweep plug-in, newer version (type 74-13A with mod 101)	F6-4	
Dual trace plug-in (type 76-02A with mod 101 and delay line)	F6-2	
Dual trace plug-in (type 76-02A with mod 103 and delay line)	F6-2.1	
Main frame, oscilloscope 765MH with mod 116	F6-1	
Main frame, oscilloscope 765MH and 765MH/F with mod 116	F6-1.1	
Service upon receipt of materiel:		
General	2-1	
General service	2-2	
Shipment and storage:		
Transportation data	7-2	
Packaging the oscilloscope	7-3	
Storage	7-4	
Signal coupling and voltage attenuation, 76-02A	3-6	
Signal coupling	3-6 <i>a</i>	
Input voltage attenuation	3-6 <i>b</i>	
Sources of trigger input, older version 74-13A	3-12 <i>a</i>	
INT position	3-12 <i>a</i> (1)	
EXT position	3-12 <i>a</i> (2)	
LINE position	3-12 <i>a</i> (3)	

	Paragraph, Figure, Table Number
Storage	7-4
Time limitations	7-4a
Storage procedure	7-4b
Inspection in administrative storage	7-4c
Sweep duration	3-13c
Tables:	
Nomenclature and reference designations	T1-1
Oscilloscope operation and maintenance data	T1-2
Main frame, controls and indicators	T2-1
Dual trace plug-in, controls and indicators	T2-2
Dual trace plug-in 70-02A, controls and indicators	T2-2.1
Dual trace plug-in 79-02A, check procedures	T2-5
Delaying sweep plug-in, controls and indicators	T2-3
Oscilloscope check procedures	T2-4
Preventive maintenance checks and services	T5-1
Troubleshooting the main frame	T5-2
Troubleshooting the dual trace plug-in type 76-02A	T5-3
Troubleshooting the delaying sweep plug-in type 74-13A	T5-4
Theory of operation, general:	
Power supply	3-1
Dual trace plug-in	3-2
Dual trace plug-in 79-02A	3-2.1
Delaying sweep plug-in	3-3
Time measurements	2-12
Time measurements using scale divisions	2-12a
Repetition rate of frequency using scale divisions	2-12b
Pulse width measurements using scale divisions	2-12c
Pulse width measurements using the DELAY VENIER control	2-12d
Trigger pick-off circuit, 76-02A	3-10
Trigger, older version 74-13A	3-12
Sources of trigger input	3-12a
Methods of coupling trigger input	3-12b
Polarity selection of input signal	3-12c
Normal trigger generation	3-12d
Automatic triggering	3-12e
Delayed trigger generation	3-12f
Troubleshooting:	
General	5-9
Troubleshooting the main frame	T5-2
Troubleshooting the dual trace plug-in type 76-02A	T5-3
Troubleshooting the dual trace plug-in 79-02A	5-9.1
Troubleshooting the delaying sweep plug-in type 74-13A	T5-4

By Order of the Secretary of the Army:

HAROLD K. JOHNSON
General, United States Army,
Chief of Staff.

Official:

KENNETH G. WICKHAM
Major General, United States Army,
The Adjutant General.

Distribution:

To be distributed in accordance with DA Form 12-32, Section II, requirements for organizational maintenance applicable to the HAWK missile system.

